

## Tery Chem – Professional Pumps for Industrial Use



Since the introduction of Polypropylene as an option for the pump body, it has steadily grown to become the largest market for AODD Pumps, the 1/2" model in particular. With this in mind whilst developing our range of Chemical Pumps we modelled our 1/2" unit to dimensionally interchange with the existing market leaders in AODD Pumps.

By utilising new thermoplastic elastomers like Santoprene<sup>®</sup> instead of EPDM, we get similar chemical resistance, but a massively improved flex life. We also now have modified PTFE giving outstanding performance over conventional PTFE diaphragms, giving us all the chemical protection and millions of strokes before change is needed.

### 1-1/2" Polypropylene

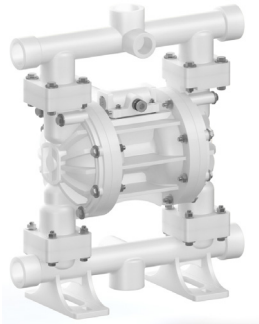

1-1/2" Polypropylene

### Performance Graphs - Nitrile/Santoprene

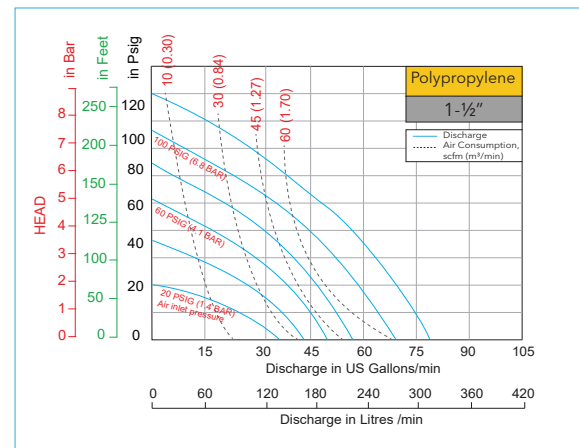

### Technical Data

Pump Size	1/2"	1"	1-1/2"	2"
Air Inlet, NPT	1/4"	1/4"	1/2"	3/4"
Max. Size Solids mm (Inch)	1.6 (1/16")	4.76 (3/16")	4.8 (3/16")	6.4 (1/4")
Max. Flow Rate lpm (gpm)	57.0 (15.0)	174 (46)	285 (75)	591 (155)
Weight, Kgs (Lbs)	4 (8)	10 (22)	15 (33)	26.5 (58)
Max. Suction Lift Dry M(Ft)	4.5 (14.7")	2.4 (7.9")	5.5 (18)	6.4 (21)
Max. Suction Lift Wet M(Ft)	9.3 (30.6")	9.4 (31.0")	8.5 (28)	8.5 (28)

### Dimensions in mm - Aluminium

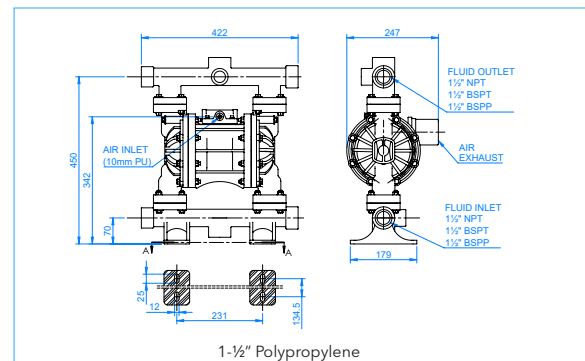

### Pump Nomenclature

Position	1	2	3	4	5	6	7	8	9	10	11
Example:	TM	12	A	B	X	R	E	X	A	X	X
<b>Example: TC40-PTS-FEX-XXX</b>											
Position 1 Range	Position 2 Size	Position 3 Body	Position 4 Diaphragm/ Valve	Position 5 Back Up	Position 6 Port	Position 7 Port Position	Position 8 Speciality Code	Position 9 Safety Code	Position 10 Sanitary Code	Position 11 Speciality Code	
TC- Chemical	15 - 1/2" 25 - 1" 40 - 1-1/2" 50 - 2"	P - Polypropylene	B - Buna (Nitrile) S - Santoprene O - One Piece PTFE T - PTFE	B - Buna (Nitrile) I - Integrated Buna S - Santoprene X - None	G - BSPT F - Flanged ANSI/DIN R - NPT P - BSPP	C - Centre Ported D - Drum E - End Ported	P - Pulse Dampener R - Remote Solenoid Driven T - Trolley Mounted X - None	X - None	X - None	S - Speed Controller C - Cycle Counter D - Diaphragm Monitoring X - None	