



# TeryPRO – Professional Pumps for Industrial Use



The 'Professional' range from Teryair is the next step for the existing portfolio. With its bolted construction and large range of options, it takes the traditional use of an AODD Pump into the broader section of the chemical and industrial markets.

TeryPro is the Professional's choice when an Air Operated Diaphragm Pump is the best solution for strength, high performance, cleaner and safer fluid transfer. AODD pumps can be held on standby for immediate use, with zero energy consumption. Coupled with Patented Air Valve Technology, TeryPro sets the standard for forward thinking consumers.

## 1" Aluminium

## 1" Stainless Steel



1" Aluminium

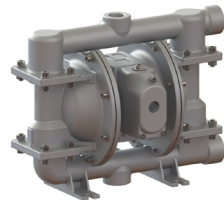

1" Stainless Steel

## Technical Data

Pump Size	1/2"	1"	1-1/2"	2"	
Air Inlet, FNPT	1/4"	1/4"	1/2"	1/2"	
Max. Size Solids mm (Inch)	1.6 (1/16)	6.4 (1/4)	1.6 (1/16)	6.4 (1/4)	
Max. Flow Rate lpm (gpm)	58.7 (15.5)	212 (56)	492 (130)	609 (161)	
Weight, Kgs (Lbs)	Aluminum	4 (8)	11 (24)	26 (57)	47 (104)
	Stainless Steel	5 (10)	23 (51)	50 (111)	73 (161)
Max. Suction Lift Dry M(Ft)	5.5 (17.0)	5.5 (18.2)	5.5 (18.2)	7.4 (24.3)	
Max. Suction Lift Wet M(Ft)	9.3 (30.6)	9.3 (30.6)	9.0 (29.5)	9.0 (29.5)	

## Available Combination

Model No	Description
TP25-ASX-REX-AXX	Teryair 1" Diaphragm Pump TeryPro Alu Santo NPT End Port / Atex
TP25-ATS-REX-AXX	Teryair 1" Diaphragm Pump TeryPro Alu PTFE-Santo NPT End Port / Atex
TP25-SSX-REX-AXX	Teryair 1" Diaphragm Pump TeryPro Stainless Santo NPT End Port / Atex
TP25 STS REX AXX	Teryair 1" Diaphragm Pump TeryPro Stainless PTFE-Santo NPT End Port / Atex

## Performance Graphs

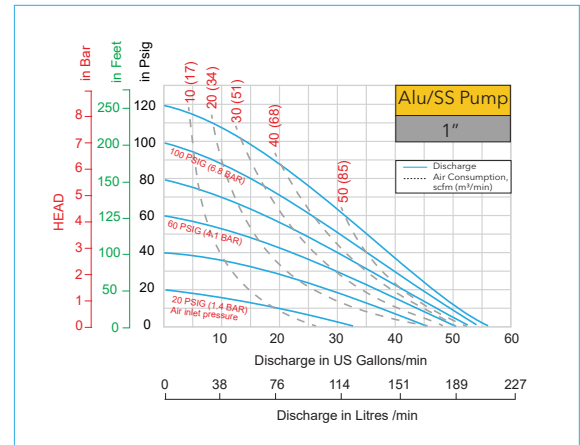

## Dimensions in mm

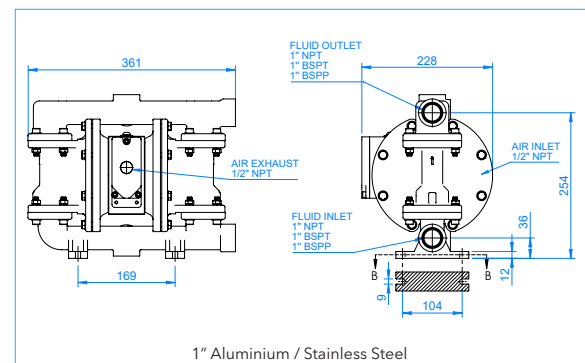

## Pump Nomenclature

Position	1	2	3	4	5	6	7	8	9	10	11
Example:	TP	15	A	B	X	R	E	X	A	X	X
<b>Example: TP25-ABX-GEX-AXX</b>											
Position 1 Range	Position 2 Size	Position 3 Body	Position 4 Diaphragm/ Valve	Position 5 Back Up	Position 6 Port	Position 7 Port Position	Position 8 Speciality Code	Position 9 Safety Code	Position 10 Sanitary Code	Position 11 Speciality Code	
TP- Industrial	15 - 1/2" 25 - 1" 40 - 1-1/2" 50 - 2"	A - Aluminium S - Stainless Steel	B - Buna (Nitrile) T - PTFE S - Santoprene	B - Buna (Nitrile) I - Integrated Buna S - Santoprene X - None	G - BSPT C - TriClamp BS 4825-3 F - Flanged ANSI/DIN R - NPT P - BSPP	C - Centre Ported D - Drum E - End Ported	P - Pulse Dampener R - Remote Solenoid Driven T - Trolley Mounted X - None	A - ATEX/ IECEx	F - FDA / EN 1935/2004 X - None	S - Speed Controller C - Cycle Counter D - Diaphragm Monitoring X - None	