



20PM

TECHNICAL DATA

RELEASED:13/09/2024
 REVISED:
 REV: 00

20PM Ex PNEUMATIC PISTON AIR MOTOR

DIMENSIONAL DATA - 20PM

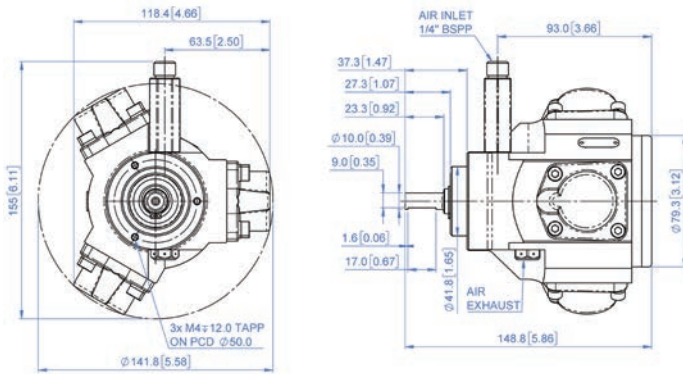

PERFORMANCE DATA

Max Output Power	0.25kW (0.33hp)
Speed at Max Power	2000 RPM
Maximum Torque	1Nm (8.8lb-In)
Air Consumption at Max Power	25.4m ³ /hr (15cfm)
Ambient Safe Operating Temperature	
• Non Explosive Zone	0°C to 120°C
• Explosive Zone	0°C to 40°C
Maximum Allowable Operating Speed In any Direction	2000 RPM
Working Pressure	7kg/cm ² (100 psi)

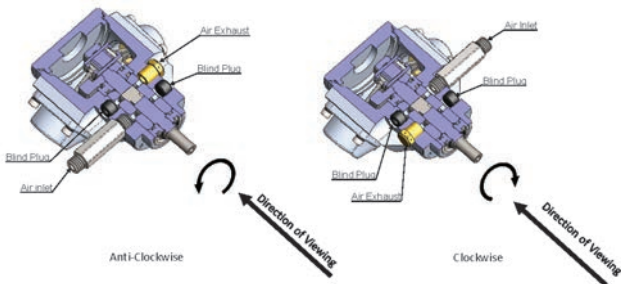

WEIGHT & FINISH

Piston Air Motor Type	Weight	Finish
20PM Hub Mounting	2.0 kgs, 4.4 lbs	Silver

MODEL NUMBER

20PM TAA EXPR3

POWER & TORQUE GRAPH

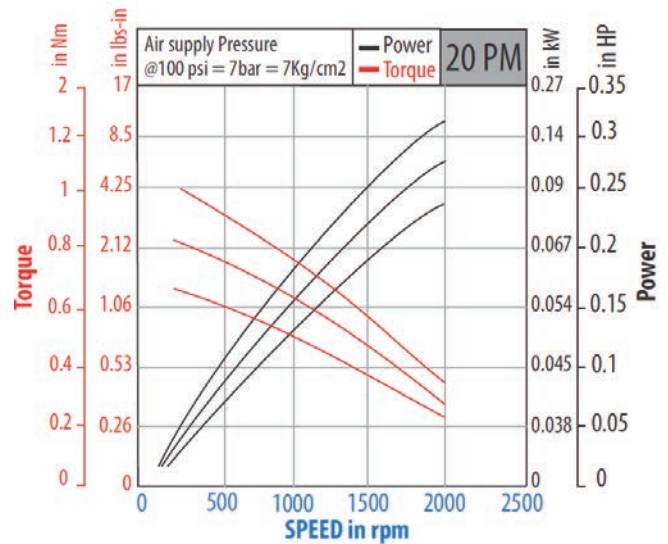

AIR MOTOR NOMENCLATURE

Size	Motor Type	Mounting	Lubricated or Lube-Free	Material of Construction	Explosion Proof	Threading on Inlet and Outlet	Direction of Rotation	No of Vanes
20	PM- Piston Type	T- Hub	A- Lubricated O - Lube Free	A - Aluminum	EX	R- NPT G - BSPT P - BSPP	R - Reversible	3



II 2GD Ex h IIC T6 Gb
 II 2GD Ex h IIIC T85° C Db