



TECHNICAL DATA

RELEASED: 12/09/2024
 REVISED:
 REV: 00

Pneumatic Sump Pumps - 2" and 2-1/2"

DIMENSIONAL DATA

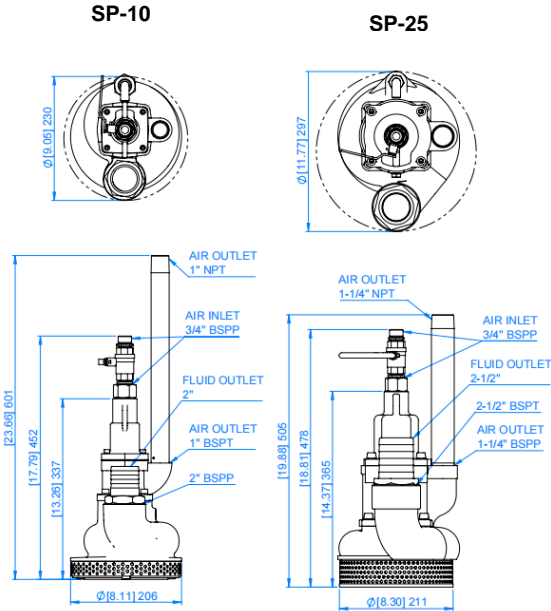

NOTE: Dimensions are shown in [inch] mm

PERFORMANCE GRAPH

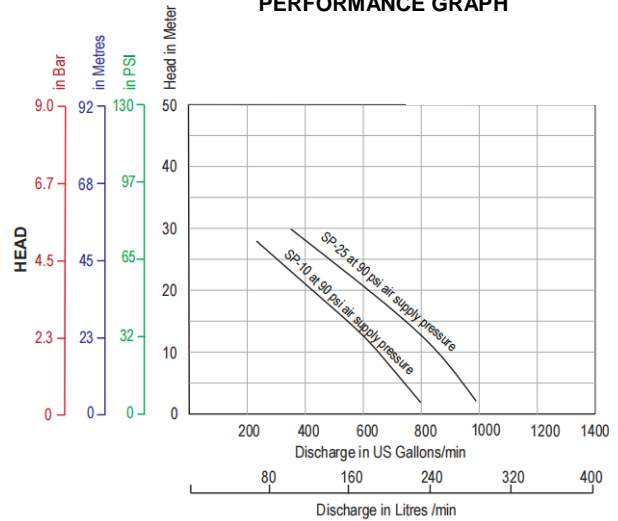

SP-10 PERFORMANCE DATA

Max. Head	25m (82 ft)
Discharge	0-466 lpm (0-123 gpm)
Max. Air Consumption	95 CFM (2.7 m ³ /min)
Water Outlet	2" BSPP
Air Inlet	3/4" BSPP
Min. Water Depth For Suction	(0.86") 22mm

SP-25 PERFORMANCE DATA

Max. Head	22m (72 ft)
Discharge	0-633 lpm (0-167 gpm)
Max. Air Consumption	123 CFM (3.5 m ³ /min)
Water Outlet	2-1/2" BSPT
Air Inlet	3/4" BSPP
Min. Water Depth For Suction	(0.86") 22mm

STANDARD EQUIPMENT INCLUDED

Model No.	Part No.	Description	Qty
SP-10	1999750	Gate Valve	1 Pc
	1992109	Discharge Nipple	1 Pc
SP-25	1999750	Gate Valve	1 Pc
	1902128	Discharge Nipple	1 Pc

ACCESSORIES AND SPARES

1999753	Repair Kit for SP-10
1909711	Repair Kit for SP-25

MODEL NUMBERS

SP-10
SP-25

WEIGHTS & FINISH

Sump Pump	Weight	Finish	MOC
SP-10	21 kgs (46 lbs)	RAL 1004, Yellow	Cast Iron
SP-25	32 kgs (70 lbs)	RAL 1004, Yellow	Cast Iron