

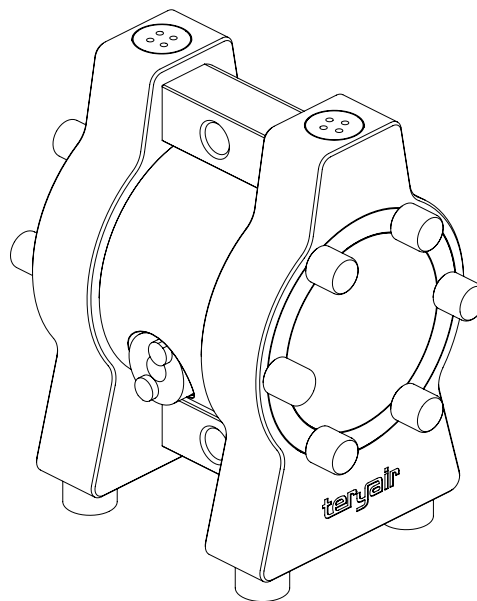

Operation and Maintenance Guide



25 PTFE

Models	Descriptions
TB25-PTI-PCX-XXX	Teryair 1” Diaphragm Pump TeryBlock PTFE PTFE-IntBuna BSPP Center Port

Read this manual carefully before installing, operating or servicing this equipment. It’s the responsibility of the employer to ensure this manual is read by the operator. Please preserve this manual.

Table of Contents

3	Pump Nomenclature
3	Operating and Safety instructions
4	Operating Instructions
5	Caution: Temperature limitations and diaphragm options
6	Suggested site selection and installation recommendations
7	Troubleshooting
8	Maintenance
8	Diassembly and Re-assembly
10	Re-Assembly
11	Maximum Torque Specifications (TB25-PTFE)
12	Exploded View for TB25-PTFE Pump
13	Bill of Materials for TB25-PTI-PCX Pump
13	Replacement & Repair Kits for TB25 Series Pump
14	Bill of Materials for TB25-UTI-PCX Pump
14	Replacement & Repair Kits for TB25 Series Pump
15	Dimensional Data
16	Eu Declaration Of Conformity
17	Warranty Certificate

Pump Nomenclature

Position	1	2	3	4	5	6	7	8	9	10	11
Example:	TB	15	A	B	X	R	E	X	A	X	X
Example: TB25-ZTI-PCX-AXX											
Position 1 Range	Position 2 Size	Position 3 Body	Position 4 Diaphragm/ Valve	Position 5 Back Up	Position 6 Port	Position 7 Port Position	Position 8 Speciality Code	Position 9 Safety Code	Position 10 Sanitary Code	Position 11 Speciality Code	
TB- Block	15 - ½" 25 - 1"	U - UHMW / PE Z - Conductive PE P - PTFE C - Conductive PTFE	T - PTFE	I - Integrated Buna	G - BSPT F - Flanged ANSI/DIN R - NPT P - BSPP	C - Centre Ported Swiveling, See Foot Note	P - Pulse Dampener R - Remote Solenoid Driven T - Trolley Mounted X - None	A - ATEX/IECEX X - None	F - FDA / EN 1935/2004 X - None	S - Speed Controller C - Cycle Counter D - Diaphragm Monitoring X - None	

Foot note 1 - Can be swivled to any degree between hozontal and vertical

Operating and Safety Instructions

Warning: Static Electricity

- Static sparks can cause explosion resulting in severe injury or death.
- Ground the pump and the pump connections like hoses and containers into which or from the fluid is being transferred. Connect the grounding wire to any bolt on the pump.
- Check continuity of electrical path to ground at regular intervals.
- Consult local building and electrical codes for grounding requirements where needed.
- Use hoses containing a grounding wire.

Warning: Pump Exhaust

In case of a diaphragm failure, fluid being pumped may spray out from the exhaust of the pump. This may cause severe injury depending on the fluid being pumped.

If the fluid is hazardous, pipe away the exhaust to a safe remote location using a generous diameter pipe preferably with a grounding arrangement, and refit the muffler at the end of this arrangement.
Always wear safety glasses while in the vicinity of an operating pump.

Warning: Over pressure / Hazardous Pressure

Do not exceed the max supply air pressure of 100 PSI.
Make sure all connected hoses and pipelines are rated to operate safely with the pressures generated by pump of 100 PSI.
Do not open or handle pump or hoses while pressurized.
Disconnect air supply line and relieve pressure from the system by carefully opening discharge and supply lines.

Warning: Hazardous Materials

Do not move a pump that contains hazardous fluids trapped inside it. Please observe prescribed handling and safety codes. Drain the pump safely, by turning it upside down and collecting the fluid safely, before moving the pump.

Warning: Explosion

Please check compatibility of fluids intended to be handled with the materials of construction of the pump. Severe reactions and explosions may occur if materials are incompatible.

 **Caution: Chemical compatibility**

Please check that the fluid being pumped is compatible with the wetted parts of the pump. Re-fer Cole Parmer compatibility (<http://www.coleparmer.in/Chemical-Resistance>) guide for de-tails. Note that chemical compatibility may change with temperature; take this into account while selecting pump material.

 **Caution: Structural support**

Please refer figure 1 and ensure that the piping system is independently supported and does not load the pump. The pumps are not designed to take the continuous and often pulsating load of a piping system. Important to use a flexible connection between rigid piping and pump casings.

 **Caution: Running dry, disconnection of hoses when not in use**

Although these pumps can be run dry for long periods, it is advisable to avoid this as it causes unnecces-sary wear of wearing parts

 **Caution: Operator understanding**

Please ensure that all operators have read this manual and have the required understanding of safe working practices and are equipped with safety equipment when working on/around the pump.

 **Caution: Using genuine teryair fittings & spares**

Use genuine teryair parts to ensure correct pump operation and maximize life.

Operating Instructions

- The Teryair diaphragm pump generates a alternate stroking of the diaphragms against the fluid in the liquid chambers of the Pump. This reciprocatory action is responsible for the fluid being pumped.
- It is possible to control the output of the pump by controlling the supply air pressure.
- It is also possible to control the output of the pump by throttling action on the fluid flowing in the outlet piping by means of a valve. if such a valve is shut completely the pressure in the discharge piping increases to a point when the pressure at pump discharge equals it and the pump comes to a stop. This causes no damage to the pump and the pump consumes no more energy.
- Upon opening of the valve, the pump starts reciprocating once again and resumes fluid delivery.

 **Caution: Temperature limitations and diaphragm options**

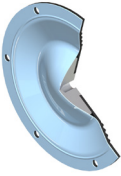
<p>Modified PTFE</p>		<p>Longer diaphragm life in more abrasive applications that still require PTFE. Available for sanitary and industrial diaphragm pumps.</p>
-----------------------------	---	--

Suggested Lubricants

Brand	Above 27 Deg C (From 5 Deg C to 27 Deg C	Below 5 Deg C
Shell	Toona R 72	Toona R 41	Toona R 27
Mobil	Almo 529	Almo 527	Almo 525
Esso	- - - - -	Arox EP 65	Arox EP 45
Caltex	Rando Oil 150	Rando Oil 100	Rando Oil 46
Texaco	Regal Oil F	Regal Oil PE	Regal Oil B
Daltron	Silkolene 881	Silkolene 548	Silkolene 773
Burmah Castrol	RD Oil 3	RD Oil Light	Megna SPX
BP	RD 220 HP60C	RD150 HP20C	RD80 HP10C
Duckham	Garnet 7	Garnet 6	Zero Flo 5
Sternol	Merlin 87	Merlin 71	Merlin 54
Petrofina	Purifoc 53	Purifoc 46	Purifoc 32
Chevron	Vistac Oil 18X	Vistac Oil 19X	Vistac Oil 9X

Suggested site selection and installation recommendations

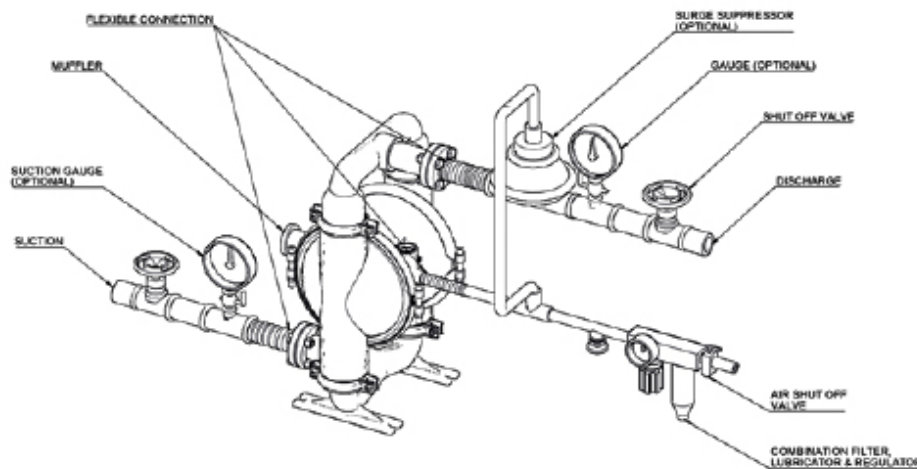

Figure 1

Location selection

Pump location must be easily accessible with reasonable space around for maintenance operations. Pump dimensional data for each variant is available in section showing exploded views

Air supply

Compressed air at 90 PSI (Stroke pumps can take a max of 100PSI), free from moisture and having an oil mist is essential. Use of a filter (50 microns), a lubricator and a regulator is highly recommended and should be installed as close as possible to the pump inlet.

Ensure correct grade of oil is used in the lubricator bowl. Too thick oil may slow down the valve shifting mechanism and affect pump performance. See suggested lubricants on page no 5.

Piping

A minimum number of bends and fittings to be used.

A flexible connection between suction, delivery and air supply piping is highly recommended such that piping stresses and loads do not transfer to pump housing. Select piping materials such that chemical compatibility is maintained with the fluid being pumped.

Suction

Ensure that the suction head after installation is well within the pumps suction capabilities

Muffler

Use of supplied muffer is recommended to bring pump operation sounds down to comfortable levels, in case of hazardous fluids handling, please read section of safety regarding piping away of exhaust see

Warning: Pump Exhaust) earlier in this manual.

Troubleshooting

Serial No	Description	Causes	Remedial Action
1	Pump stops and will not start	Insufficient Air Pressure	Check air pressure is as recommended at the pump air inlet
		Air Filter Blocked	Check if debris has clogged the inlet filter on the FRL unit/pump inlet air valve (some models have air filter on the air inlet valve) and ensure clear passage of air
		Internal damage or excessive wear on components	Proceed to dismantle the pump, examine component for wear, replace any worn components, re assemble carefully as instructed in this manual and re start the pump.
2	Pumps runs slowly, poor delivery	Cavitation	Check if cavitation is occurring in the suction side, if so reduce suction vacuum by slowing down the pump.
		Worn Balls and Seats	Check proper sealing action of balls against seals, these components need to be replaced as a set if they are worn.
		Insufficient or wrong lubricant in the air supply.	Ensure that the lubricant is as per the recommended chart, a thicker lubricant often makes the air valve work sluggishly
		Internal damage or excessive wear on components	Proceed to dismantle the pump, examine component for wear, replace any worn components, re assemble carefully as instructed in this manual and re start the pump.
3	Pump air valve freezes	Excessive moisture in supply air line.	Ensure that the dew point of the supplied air is low enough. Install a air dryer or moisture separator on the supply line
4	Air bubbles in pump discharge or product sprays out of exhaust vent	Broken Diaphragm	Proceed to dismantle the pump, examine component for wear, replace any worn components, re assembly carefully as instructed in this manual and re start the pump
		Improper seal between inner pistons, outer pistons and shaft.	
		Air leakage into product from balls / seats area	
		Air sucked into suction pipeline due to insufficiently tight joints on suction pipeline.	

Maintenance

Regular inspection and maintenance schedules will greatly enhance the life of the pump and will ensure a trouble free and safe working environment with little chance of breakdowns.

Follow the instructions clearly in “Disassembly and Reassembly” of the pump and in the troubleshooting section.

Use genuine Teryair spares and if possible mention the serial number of the pump when ordering spares.

Always replace elastomers as a set, eg diaphragms, balls and seats.

Diassembly and Re-assembly

- Shut off air supply and allow residual Pressure to bleed off.
- Disconnect air supply
- Disconnect suction and discharge piping
- Turn pump upside down allow process fluid to drain away. If fluid is hazardous due care should be taken.
- Make a mark to indicate the positioning of each liquid chamber relative to the housing.
- NOTE: Replace worn parts with genuine Teryair parts for reliable performance.

1. Replacement of Diaphragm

- a. First unscrew the 6 no.s of safety cap (16) then unscrew Hex nylock nut (32).
- b. Now remove the SS Ring (33) and pull the chamber plate assembly (2) from the Shaft Housing (1) and stud (18).
- c. Now pull the Shaft Housing assembly with Diaphragm (19) from other side Chamber Plate assembly.
- d. Now hold the primary Shaft (17) by spanner and unscrew the diaphragm (19) and replace with new one. Repeat the same process for another diaphragm (19).

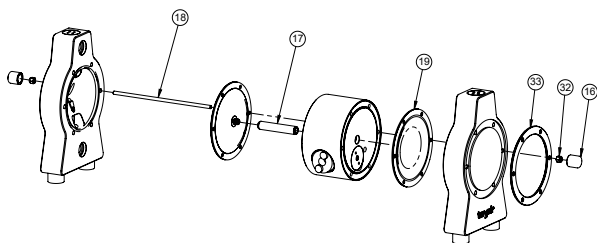

2. Replacement of Ball & O-Rings

- a. Follow the step a, b & c of replacement of Diaphragm.
- b. Unscrew top plug (4) with the help of key & remove.
- c. Now replace the O ring (30) & ball valve (7).
- d. Now unscrew the valve stopper screw (9) with the help of screw driver & remove.
- e. Now slide valve stopper (8) at up side in the chamber plate.
- f. Now replace the ball valve (7).
- g. Now unscrew bottom plug (5) with the help of key & remove.
- h. Now replace the O ring (31).

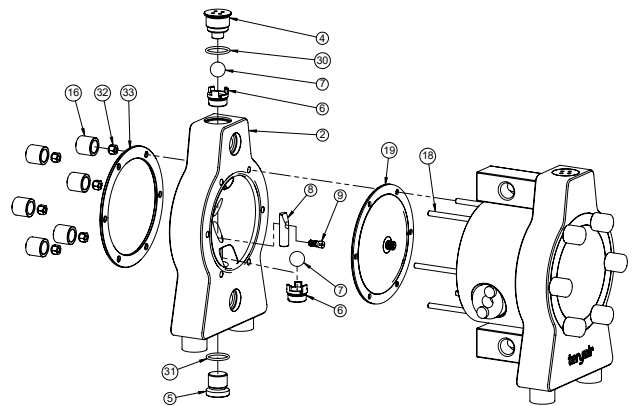

3. Replacement of Shaft Seals

a) For removing the seals from shaft housing, first follow the steps a, b, c & of diaphragm replacement.

b) Now remove the seals (20) with the help of needle Nose pliers. Care should be taken not to damage the inner face of shaft housing (1)

c) Once all the old seals are have been removed, the inside of the shaft housing (1) should be cleaned to ensure no debris is left that may damage to new seals (Pressurized air is preferable)

e) The Blunt point Needle can be used to aid in the installation of new seals.

d) These following tools can be used to aid in the installation of new seals:

- Needle Nose pliers
- Phillips Screwdriver
- Electrical Tape

e. Wrap electrical tape around each leg of the needle nose pliers (heat shrink may also be used) . This is done to prevent damaging the inside portion of the new seals.

f. With a new seal in hand, place the two legs of the

nose pliers inside the seal ring. Open the pliers as wide as the seal diameter will allow, then two fingers pull down on the top portion of the seal

to form kidney bean shape. (Refer Fig. A)

g. Lightly clamp the pliers together to hold the seal into the kidney shape. Be sure to pull the seal into as tight of a kidney shape as possible, this will allow the seal to travel down the bushing bore easier. (Refer Fig. B)

h. With the seal clamped in the pliers, insert the seal into the bushing bore and position the bottom of the seal into the correct groove. Once the bottom of the seal is seated in the groove, release the clamp pressure on the pliers. This will allow the seal to partially snap back to its original shape.

i. After the pliers are removed, you will notice a slight bump in the seal shape. Before the seal can be properly re-sized, the bump in the seal should be removed as much as possible. This can be done with either the Phillips screw driver or your finger, apply light pressure to the peak of the bump.

j. This pressure will cause the bump to be almost completely eliminated.

k. Lubricate the edge of the shaft with specified lubricant.

l. Slowly insert the shaft with rotating motion. This will complete the re-sizing of the seals.

m. Perform these steps for the remaining seals.

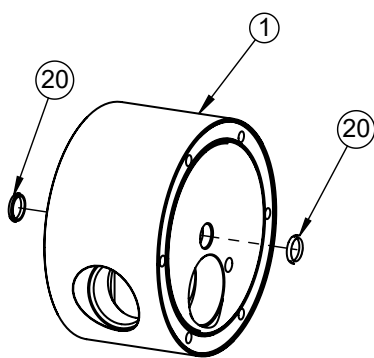

Air Valve/ Center Section Disassembly

4. Replacement Of Secondary Shaft Assembly

- Follow the steps a, b, c, d from the diaphragm replacement.
- Now unscrew the both side Side Plug (13) form shaft housing (1) with the help of proper tools.
- Now remove the O-Rings (25) & (27) and replace with new one.
- Also replace the Secondary Shaft (12) with new one.
- For removing Sleeve from shaft housing, push the Sleeve (10) with its O-Rings from one side of Shaft housing (1) and replace with new one.
- For removing Piston assembly (11) from shaft housing, push it from Sleeve (10) and replace with new one. [Sleeve & Spool replace with it's seals & O rings.

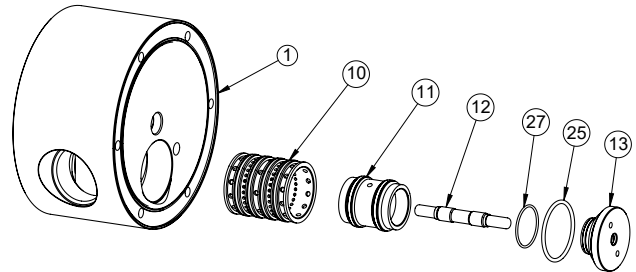

Re-Assembly

Upon performing applicable maintenance to the air distribution system, the pump can now be reassembled. Please refer to the dis-assembly instructions for photos and parts placement. To reassemble the pump, follow the dis-assembly instructions in reverse order. The air distribution system needs to be assembled first, then the Dia-phragms and finally the wetted path. Please find the applicable torque specifications on this page. The following tips will assist in the assembly process.

- Clean the inside of the center section shaft bore to ensure no damage is done to new seals.
- Stainless bolts should be lubed to reduce the possibility of seizing during tightening.
- Level the water chamber side of the intake/ discharge manifold to ensure a proper sealing surface. This is most easily accomplished by placing them on a flat surface prior to tightening their clamp bands to the desired torque (see below for Torque Specifications).
- Be sure to tighten outer pistons simultaneously on PTFE-fitted pumps to ensure proper torque values.
- Ensure proper mating of liquid chambers to manifolds prior to tightening vertical bolts. Overhang should be equal on both sides.
- Apply a small amount of Loctite 242 to the shaft interval threads before the diaphragm assembly. Concave side of disc spring in diaphragm assembly face

Maximum Torque Specifications (TB25-PTFE)

Description Of Part	Torque
Air Valve	5.1 N•m (45 in-lb)
Air Chamber/Center Block	47.5 N•m (35 ft-lb)
Outer Flanges, Rubber & PTFE, Excluding Stainless Steel Inner Pistons	106 N•m (78 ft-lb)
Outer Flanges, Rubber & PTFE, Stainless Steel Inner Pistons	119 N•m (88 ft-lb)
Outer Flanges, Ultra-Flex™	74.6 N•m (55 ft-lb)
Small Clamp Bands	6.6 N•m (58 in-lb)
Large Clamp Bands (Rubber-Fitted)	47.5 N•m (35 ft-lb)
Large Clamp Bands (PTFE-Fitted)	47.5 N•m (35 ft-lb)

Exploded View for TB25-PTFE Pump

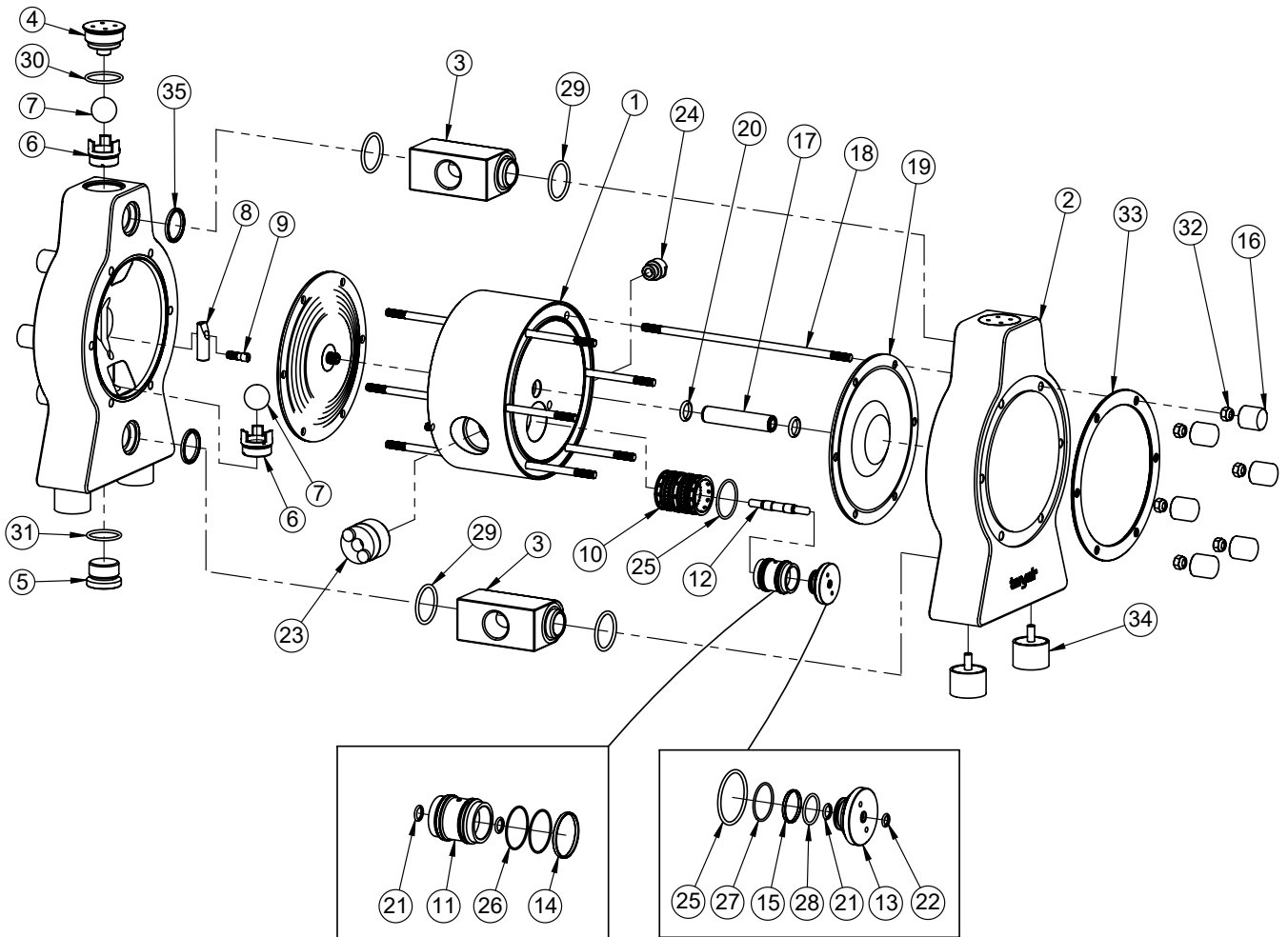

Note.

The additional parts for Flange model are as below

ITEM. NO.	PART NUMBER	DESCRIPTION	Flange
-	2143613	Flange Adapter	2
-	2144102	O Ring	2

Bill of Materials for TB25-PTI-PCX Pump

ITEM NO.	PART NUMBER	DESCRIPTION	Qty
1	2143601	Shaft Housing-TB25	1
2	2143602	Chamber Slide Plate-TB25	2
3	2143603	Manifold-TB25	2
4	2143604	Top Plug-TB25	2
5	2143605	Bottom Plug-TB25	2
6	2143606	Ball Seat-TB25	4
7	2143607	Ball Seat-TB25	4
8	2143608	Valve Stopper-TB25	2
9	2143609	Screw-TB25	2
10	2133610	Sleeve-TB15/25	1
11	2133611	Air Piston-TB15/25	1
12	2133612	Secondary Shaft-TB15/25	1
13	2133613	Side Plug-TB15/25	2
14	2133614	Seal	2
15	2133615	Seal	2
16	2143612	Safety Cap-TB25	12
17	2142701	Primary Shaft-TB25	1

ITEM NO.	PART NUMBER	DESCRIPTION	Qty
18	2142702	Chamber Stud-TB25	6
19	2146001A	Diaphragm Integrated-TB25	2
20	2146003	D Seal	2
21	2136003	D Seal	4
22	2136004	D Seal	2
23	2130801	Silencer	1
24	2130802	Adapter	1
25	2134001	O Ring	6
26	2134002	O Ring	4
27	2134003	O Ring	2
28	6124032	O Ring	2
29	1644106	O Ring	4
30	2144101	O Ring	2
31	2144102	O Ring	2
32	1265030S	Hex Nylock Nut	12
33	2148201	Safety Ring-TB25	2
34	2145001	Shock Absorber-TB25	4
35	2146002	Bonded Seal-TB25	4

Note.

The additional parts for Flange model are as below

ITEM. NO.	PART NUMBER	DESCRIPTION	Flange
-	2143613	Flange Adapter	2
-	2144102	O Ring	2

Replacement & Repair Kits for TB25 Series Pump

ITEM NO.	PART NUMBER	DESCRIPTION	Replacement Kit 2139701	Repair Kit 2139702
10	2133610	Sleeve-TB15/25	1	1
11	2133611	Air Piston-TB15/25	1	1
12	2133612	Secondary Shaft-TB15/25	1	1
13	2133613	Side Plug-TB15/25	2	2
14	2133614	Seal	2	2
15	2133615	Seal	2	2
19	2146001A	Diaphragm Integrated-TB25	-	2
20	2146003	D Seal	-	2
21	2136003	D Seal	4	4
22	2136004	D Seal	2	2
25	2134001	O Ring	6	6
26	2134002	O Ring	4	4
27	2134003	O Ring	2	2
28	6124032	O Ring	2	2
29	1644106	O Ring	-	4
30	2144101	O Ring	-	2
31	2144102	O Ring	-	2
35	2146002	Bonded Seal-TB25	-	4

Bill of Materials for TB25-UTI-PCX Pump

ITEM NO.	PART NUMBER	DESCRIPTION	Qty
1	2143601	Shaft Housing-TB25	1
2	2143602U	Chamber Side Plate-TB25	2
3	2143603U	Manifold-TB25	2
4	2143604U	Top Plug-TB25	2
5	2143605U	Bottom Plug-TB25	2
6	2143606U	Ball Seat-TB25	4
7	2143607	Ball Seat-TB25	4
8	2143608U	Valve Stopper-TB25	2
9	2143609U	Screw-TB25	2
10	2133610	Sleeve-TB15/25	1
11	2133611	Air Piston-TB15/25	1
12	2133612	Secondary Shaft-TB15/25	1
13	2133613	Side Plug-TB15/25	2
14	2133614	Seal	2
15	2133615	Seal	2
16	2143612	Safety Cap-TB25	12
17	2142701	Primary Shaft-TB25	1

ITEM NO.	PART NUMBER	DESCRIPTION	Qty
18	2142702	Chamber Stud-TB25	6
19	2146001A	Diaphragm Integrated-TB25	2
20	2146003	D Seal	2
21	2136003	D Seal	4
22	2136004	D Seal	2
23	2130801	Silencer	1
24	2130802	Adapter	1
25	2134001	O Ring	6
26	2134002	O Ring	4
27	2134003	O Ring	2
28	6124032	O Ring	2
29	1644106	O Ring	4
30	2144101	O Ring	2
31	2144102	O Ring	2
32	1265030S	Hex Nylock Nut	12
33	2148201	Safety Ring-TB25	2
34	2145001	Shock Absorber-TB25	4
35	2146002	Bonded Seal-TB25	4

Note.

The additional parts for Flange model are as below

ITEM. NO.	PART NUMBER	DESCRIPTION	Flange
-	2143613	Flange Adapter	2
-	2144102	O Ring	2

Replacement & Repair Kits for TB25 Series Pump

ITEM NO.	PART NUMBER	DESCRIPTION	Replacement Kit 2139701	Repair Kit 2139702
10	2133610	Sleeve-TB15/25	1	1
11	2133611	Air Piston-TB15/25	1	1
12	2133612	Secondary Shaft-TB15/25	1	1
13	2133613	Side Plug-TB15/25	2	2
14	2133614	Seal	2	2
15	2133615	Seal	2	2
19	2146001A	Diaphragm Integrated-TB25	-	2
20	2146003	D Seal	-	2
21	2136003	D Seal	4	4
22	2136004	D Seal	2	2
25	2134001	O Ring	6	6
26	2134002	O Ring	4	4
27	2134003	O Ring	2	2
28	6124032	O Ring	2	2
29	1644106	O Ring	-	4
30	2144101	O Ring	-	2
31	2144102	O Ring	-	2
35	2146002	Bonded Seal-TB25	-	4

Dimensional Data

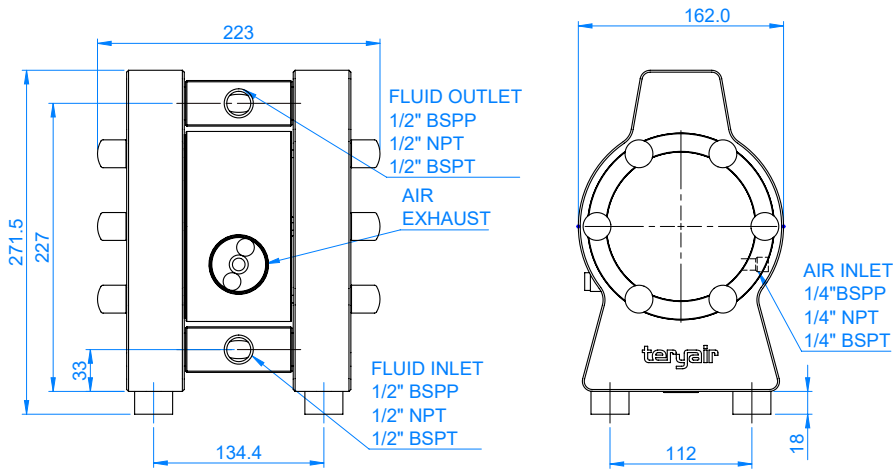

EU DECLARATION OF CONFORMITY

Object of declaration

PRODUCT : **AIR OPERATED DOUBLE DIAPHRAGM PUMP**

MODEL : **TB25 Series**

MANUFACTURER'S NAME : **TERYAIR EQUIPMENT PVT. LTD.**

ADDRESS : **SITE - 1 : BUILDING A - 1/2, 102 TO 105 & BUILDING C 12 & 13,
TIRUPATI UDYOG NAGAR, SATIVALI ROAD, VASAI (E),
PALGHAR: 401208.
SITE - 2: AUGUSTINE - II, COLACO INDUSTRIAL COMPLEX,
GALA NO - 101 TO 107, SATIVALI ROAD, VILLAGE WALIV,
VASAI (E), PALGHAR: 401208**

To provide presumption of conformity in order to directive 2014/34/EU; the following harmonized standards and/or other normative documents as referenced within the following official journals are applied:

APPLICABLE DIRECTIVE: ATEX DIRECTIVE (2014/34/EU)

APPLICABLE STANDARDS:

EN ISO 80079-36: 2016 : Explosive atmospheres —Part 36: Non-electrical equipment for explosive atmospheres —Basic method and requirements.

EN ISO 80079-37:2016 : Explosive atmospheres —Part 37: Non-electrical equipment for explosive atmospheres —Non- electrical type of protection constructional safety 'c', control of ignition sources 'b', liquid immersion 'k'.

Notified body to whom Technical file has logged with: - Technicka Inspekcia (Ref: 1354).

DECLARATION: - TERYAIR EQUIPMENT PVT. LTD., declare that under our sole responsibility for the supply of the product defined above, the said product complies with all the applicable Directives, Regulations and all essential Health and Safety requirements applying to it.

I, the undersigned, hereby declare that the product specified above conforms to the above standard(s).

ATEX MARKING APPLIED

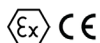

Please Refer ATEX Rating for **Teryair Aodd Models Table**

Signed for and on behalf of

TERYAIR EQUIPMENT PVT. LTD.

Place of Issue : Vasai



Warranty Certificate

Every product manufactured by Teryair
is built to meet the highest standards of quality.

Teryair warrants that the Products, accessories and parts manufactured or supplied by the company be free from defects in material and workmanship for a period of six months from date of Teryair authorized dealer invoice to customer, or one year from date of Teryair invoice to dealer, whichever is earlier. Failure due to normal wear, misapplication, or abuse is, of course, excluded from this warranty.

Since the use of Teryair products and parts is beyond our control, Teryair cannot guarantee the suitability of any product or part for a particular application and Teryair shall not be liable for any consequential damage or expense arising from the use or misuse of its products on any application. Teryair does not warranty bought out products or components such as electric motors and hardware but will assist in directing warranty queries to the dealer/manufacturer responsible. Teryair responsibility is limited solely to replacement or repair of defective Teryair products or components.

Dealer/End User shall have no right or remedy and Teryair shall have no liability or obligation under the warranty, if: (i) a Product is altered, changed, modified or tampered with in any way; (ii) a Product is damaged after deposit with the transporter for shipment; (iii) a Product is not properly preserved, packaged, stored, processed or handled after receipt; (iv) a Product is not used and maintained in accordance with Teryair's recommended operating and maintenance manuals, instructions and procedures, if any; (v) a Product is not properly incorporated or installed in, or not properly combined with, an Other Product; (vi) the issue with a Product is directly or indirectly attributable to, or directly or indirectly results from or arises out of, a failure, substandard performance or other issue with another product, material, component or part not supplied by Teryair; (vii) the issue with a Product is directly or indirectly attributable to, or directly or indirectly results from or arises out of, compliance with any design, specification or other specific requirement of Dealer/End User; (viii) a Product is used in a manner, with a substance or for a purpose other than the normal manner, substance and purpose for which it is intended or is otherwise subjected to abnormal use or service; (ix) a Product is subjected to a power surge, brown out or other similar occurrence; (x) the issue with a Product is directly or indirectly attributable to, or directly or indirectly results from or arises out of, normal wear and tear of such Product (including, without limitation, things such as worn seals, diaphragms, balls, O rings, gaskets, chisels, cutters, hoses and other such wearing components; (xi) the issue with a Product is directly or indirectly.

A handwritten signature in blue ink, appearing to be "M. Yadav", written over a horizontal line.

M Yadav, Q.A. Manager

(Company Seal)

This page is intentionally
Left blank.