

Operation and Maintenance Guide

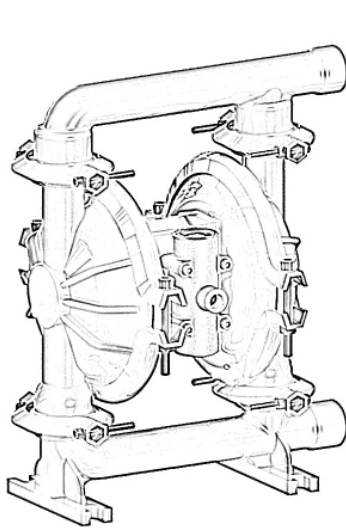

TM 25 ALX

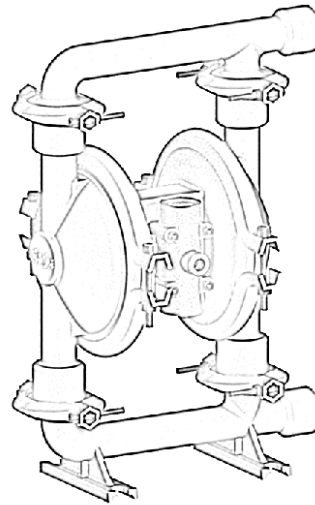

TM 25 SSX

TM 25 Aluminum and Stainless Steel Construction, All variants

Models	Descriptions
TM 25 ALX	Aluminum with Neoprene, Buna N, Santoprene and PTFE fitments
TM 25 SSX	Stainless Steel with Neoprene, Buna N, Santoprene and PTFE fitments

Read this manual carefully before installing, operating or servicing this equipment. It's the responsibility of the employer to ensure this manual is read by the operator. Please preserve this manual.

Table of Contents

3	Pump Nomenclature
3	Operating and Safety Instructions
4	Operating Instructions
5	Suggested Lubricants
6	Suggested site selection and installation recommendations
7	Troubleshooting
8	Maintenance
8	Diassembly and Re-assembly
10	Bill of Materials for TM25-ANX-REX-AXX Pump
11	Exploded View for TM 25 Pump
12	Bill of Materials for TM25-ABX-REX-AXX Pump
13	Bill of Materials for TM25-ASX-REX-AXX Pump
14	Bill of Materials for TM25-ATN-REX-AXX Pump
15	Bill of Materials for TM25-SNX-REX-AXX Pump
16	Bill of Materials for TM25-SBX-REX-AXX Pump
17	Bill of Materials for TM25-SSX-REX-AXX Pump
18	Bill of Materials for TM25-STN-REX-AXX Pump
19	Dimensional Data
19	Repair Kits for ALX Pumps & Repair Kits for SSX Pumps
20	Repair and Replacement Kits
21	Eu Declaration Of Conformity
22	Summery For The Atex Rating For Teryair Aodd Models
23	Warranty Certificate

Pump Nomenclature

Position	1	2	3	4	5	6	7	8	9	10	11
Example:	TM	12	A	B	X	R	E	X	A	X	X
Example: TM12-ABX-GEX-AXX											
Position 1 Range	Position 2 Size	Position 3 Body	Position 4 Diaphragm/ Valve	Position 5 Back Up	Position 6 Port	Position 7 Port Position	Position 8 Speciality Code	Position 9 Safety Code	Position 10 Sanitary Code	Position 11 Speciality Code	
TM- Marine	12 - 1/2" 25 - 1" 40 - 1-1/2" 50 - 2" 75 - 3"	A - Aluminium S - Stainless Steel	B - Buna (Nitrile) T - PTFE S - Santoprene N - Neoprene	B - Buna (Nitrile) S - Santoprene N - Neoprene X - None	G - BSPT R - NPT P - BSPP	*As per Picture Only	P - Pulse Dampener R - Remote Solenoid Driven T - Trolley Mounted X - None	A - ATEX/ IECEx	X - None	S - Speed Controller C - Cycle Counter D - Diaphragm Monitoring X - None	

Operating and Safety Instructions

Warning. Static Electricity

Static sparks can cause explosion resulting in severe injury or death.

Ground the pump and the pump connections like hoses and containers into which or from the fluid is being transferred. Connect the grounding wire to any bolt on the pump.

Check continuity of electrical path to ground at regular intervals.

Consult local building and electrical codes for grounding requirements where needed.

Use hoses containing a grounding wire.

Warning: Pump Exhaust

In case of a diaphragm failure, fluid being pumped may spray out from the exhaust of the pump. This may cause severe injury depending on the fluid being pumped.

If the fluid is hazardous, pipe away the exhaust to a safe remote location using a generous diameter pipe preferably with a grounding arrangement, and refit the muffler at the end of this arrangement.

Always wear safety glasses while in the vicinity of an operating pump.

Warning: Overpressure / Hazardous Pressure

Do not exceed the max supply air pressure of 125 PSI.

Make sure all connected hoses and pipelines are rated to operate safely with the pressures generated by pump of 125 PSI.

Do not open or handle pump or hoses while pressurized.

Disconnect air supply line and relieve pressure from the system by carefully opening discharge and supply lines.

Warning: Hazardous Materials

Do not move a pump that contains hazardous fluids trapped inside it. Please observe prescribed handling and safety codes. Drain the pump safely, by turning it upside down and collecting the fluid safely, before moving the pump.

Warning :Explosion

Please check compatibility of fluids intended to be handled with the materials of construction of the pump. Severe reactions and explosions may occur if materials are incompatible. Caution: Chemical compatibility

Please check that the fluid being pumped is compatible with the wetted parts of the pump. Refer Cole Parmer compatibility (<http://www.coleparmer.in/Chemical-Resistance>) guide for details. Note that chemical compatibility may change with temperature; take this into account while selecting pump material.



Caution: Structural support

Please refer figure 1 and ensure that the piping system is independently supported and does not load the pump. The pumps are not designed to take the continuous and often pulsating load of a piping system. Important to use a flexible connection between rigid piping and pump casings.



Caution: Running dry, disconnection of hoses when not in use

Although these pumps can be run dry for long periods, it is advisable to avoid this as it causes unnecessary wear of wearing parts.



Caution: Operator understanding

Please ensure that all operators have read this manual and have the required understanding of safe working practices and are equipped with safety equipment when working on/around the pump.



Caution: Using genuine teryair fittings & spares

Use genuine teryair parts to ensure correct pump operation and maximize life.



Warning Conditions for Certification

1. Control of Environmental humidity to minimize the generation of the static electricity.
2. Protection from direct airflow causing a charge transfer.
3. Touch with an insulating object to avoid electrostatic charge hazard.
4. Clean the surface with damp cloth only to avoid electrostatic charge hazard.

Operating Instructions





The Teryair Stroke diaphragm pump generates a alternate stroking of the diaphragms against the fluid in the liquid chambers of the Pump. This reciprocatory action is responsible for the fluid being pumped.

It is possible to control the output of the pump by controlling the supply air pressure.

It is also possible to control the output of the pump by throttling action on the fluid flowing in the outlet piping by means of a valve. if such a valve is shut completely the pressure in the discharge piping increases to a point when the pressure at pump discharge equals it and the pump comes to a stop. This causes no damage to the pump and the pump consumes no more energy. Upon opening of the valve, the pump starts reciprocating once again and resumes fluid delivery.



Caution: Temperature limitations and diaphragm options

Neoprene		An excellent general-purpose diaphragm for use in non-aggressive applications such as water-based slurries, well water or sea water. Exhibits excellent flex life and low cost. Temperature range -18°C to +93°C (0°F to +200°F)
Nitile		Excellent for applications involving petroleum / oil-based fluids such as leaded gasolines, fuel oils, non-synthetic hydraulic oils, kerosene, turpentine and motor oils. Temperature range -12°C to +82°C (+10°F to +180°F)
Santoprene		Good abrasion resistance. Low cost. Can handle mild acids and alkalis well. Excellent low cost alternative to ptf. Excellent suction capabilities Excellent general purpose diaphragm. Temperature range -40°C to +107°C (-40F to +225°F)
PTFE		Excellent choice when pumping highly aggressive fluids such as aromatic or chlorinated hydrocarbons, acids, caustics, ketones and acetates. Temperature range +4°C to +104°C (+40°F to +220°F)

Suggested Lubricants

Brand	Above 27 Deg C (From 5 Deg C to 27 Deg C	Below 5 Deg C
Shell	Toona R 72	Toona R 41	Toona R 27
Mobil	Almo 529	Almo 527	Almo 525
Esso	- - - -	Arox EP 65	Arox EP 45
Caltex	Rando Oil 150	Rando Oil 100	Rando Oil 46
Texaco	Regal Oil F	Regal Oil PE	Regal Oil B
Daltron	Silkolene 881	Silkolene 548	Silkolene 773
Burmah Castrol	RD Oil 3	RD Oil Light	Megna SPX
BP	RD 220 HP60C	RD150 HP20C	RD80 HP10C
Duckham	Garnet 7	Garnet 6	Zero Flo 5
Sternol	Merlin 87	Merlin 71	Merlin 54
Petrofina	Purifoc 53	Purifoc 46	Purifoc 32
Chevron	Vistac Oil 18X	Vistac Oil 19X	Vistac Oil 9X

Suggested site selection and installation recommendations

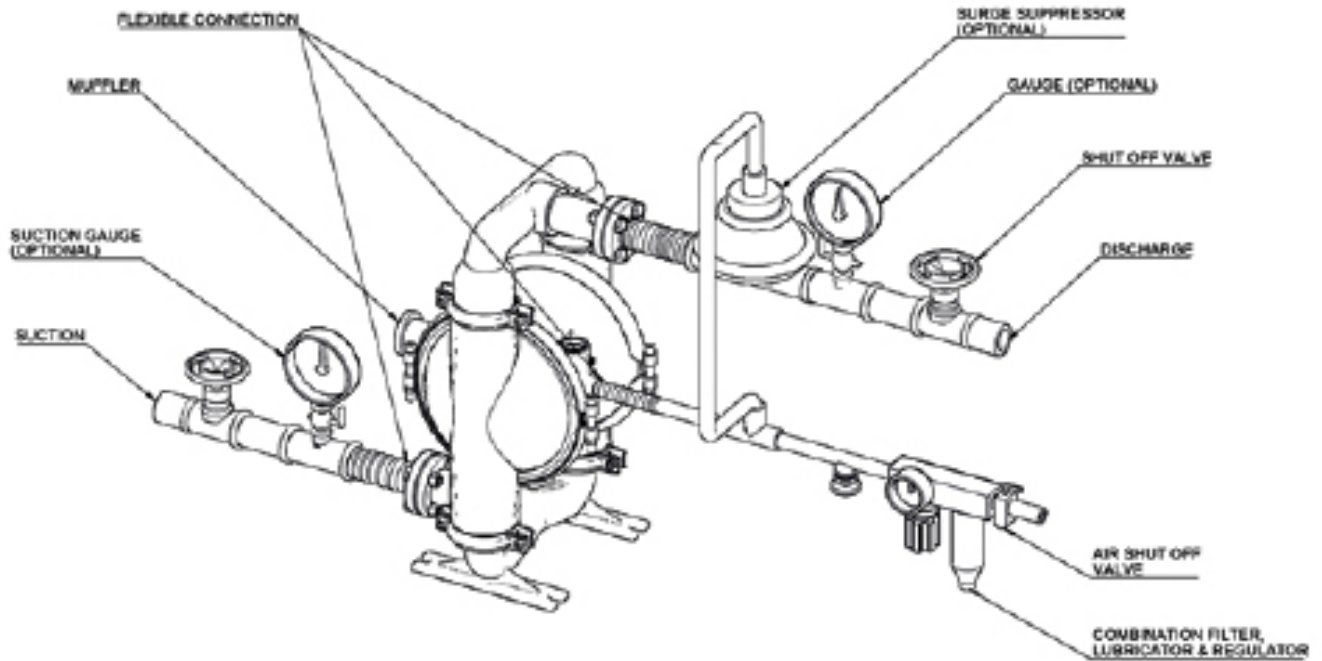

Location selection

Pump location must be easily accessible with reasonable space around for maintenance operations.
 Pump dimensional data for each variant is available in section showing exploded views

Air supply

Compressed air at 90 PSI (Stroke pumps can take a max of 125PSI), free from moisture and having an oil mist is essential. Use of a filter (50 microns), a lubricator and a regulator is highly recommended and should be installed as close as possible to the pump inlet.
 Ensure correct grade of oil is used in the lubricator bowl. Too thick oil may slow down the valve shifting mechanism and affect pump performance. See suggested lubricants on page no 5.

Piping

see section on safety if used in hazardous area)
 See Figure 1.
 Suction side 1 inch or larger, non-collapsible
 Delivery side 1 inch or larger.
 A minimum number of bends and fittings to be used.
 A flexible connection between suction, delivery and air supply piping is highly recommended such that piping stresses and loads do not transfer to pump housing.
 Select piping materials such that chemical compatibility is

maintained with the fluid being pumped.

Suction

Ensure that the suction head after installation is well within the pumps suction capabilities

Muffler / Silencer

Use of supplied muffler is recommended to bring pump operation sounds down to comfortable levels, in case of hazardous fluids handling, please read section of safety regarding piping away of exhaust see (Warning: Pump Exhaust) earlier in this manual.

Troubleshooting

Serial No	Description	Causes	Remedial Action
1	Pump stops and will not start	Insufficient Air Pressure	Check air pressure is as recommended at the pump air inlet
		Air Filter Blocked	Check if debris has clogged the inlet filter on the FRL unit/pump inlet air valve (some models have air filter on the air inlet valve) and ensure clear passage of air
		Internal damage or excessive wear on components	roceed to dismantle the pump, examine component for wear, replace any worn components, re assemble carefully as instructed in this manual and re start the pump.
2	Pumps runs slowly, poor delivery	Cavitation	Check if cavitation is occurring in the suction side, if so reduce suction vacuum by slowing down the pump.
		Worn Balls and Seats	Check proper sealing action of balls against seals, these components need to be replaced as a set if they are worn.
		Insufficient or wrong lubricant in the air supply.	Ensure that the lubricant is as per the recommended chart, a thicker lubricant often makes the air valve work sluggishly
		Internal damage or excessive wear on components	Proceed to dismantle the pump, examine component for wear, replace any worn components, re assemble carefully as instructed in this manual and re start the pump.
3	Pump air valve frerzes	Excessive moisture in supply air line.	Ensure that the dew point of the supplied air is low enough. Install a air dryer or moisture separator on the supply line
4	Air bubbles in pump discharge or product sprays out of exhaust vent	Broken Diaphragm	Proceed to dismantle the pump, examine component for wear, replace any worn components, re assembly carefully as instructed in this manual and re start the pump
		Improper seal between inner pistons, outer pistons and shaft.	
		Air leakage into product from balls / seats area	
		Air sucked into suction pipeline due to insufficiently tight joints on suction pipeline.	

Maintenance

Regular inspection and maintenance schedules will greatly enhance the life of the pump and will ensure a trouble free and safe working environment with little chance of breakdowns. Follow the instructions clearly in “Disassembly and Reassembly” of the pump and in the troubleshooting section.

Use genuine Teryair spares and if possible mention the serial number of the pump when ordering spares.

Always replace elastomers as a set, eg diaphragms, balls and seats.

Diassembly and Re-assembly

1. Replacement of Diaphragm

a) Unscrew both bolt (26) & nut (27) as shown in the exploded view and proceed to remove the small clamp (10). Repeat for the other three small clamps. Remove the outlet (3) & inlet (2) respectively. Examine the balls, seals (and seats) for wear.

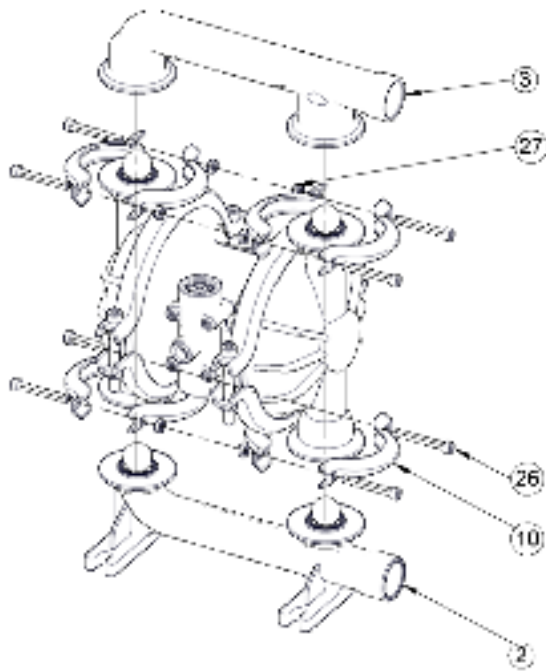

b. Now unscrew hex socket head bolt (25) & nut (29) of any one side and proceed to remove the big clamp (9). Now remove the outer chamber (6). Now repeat the same procedure to remove the second outer chamber (6)

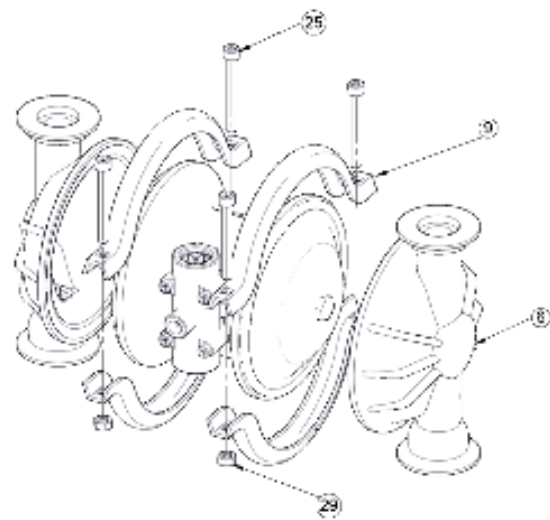

c. Now with the help of two spanner hold one of the across flat of one outer flange (5) and rotate the second outer flange (5) to disassemble it from the shaft assembly. Remove the diaphragm (11), & inner flange (4). Now pull out the shaft assembly out of the shaft housing (1).

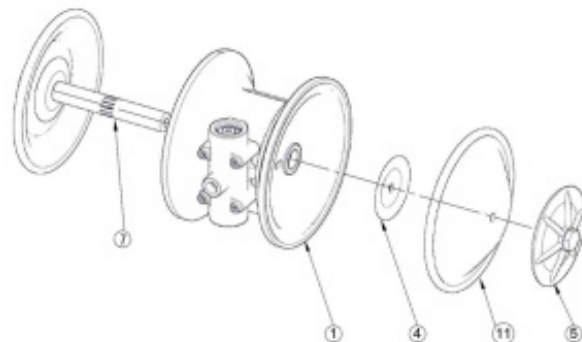

*For ALT/SST series hold one of the across flat of hex. Bolt (23) and rotate the second bolt (23) to disassemble it from the shaft assembly. Remove the washer (23A) and outer flange (5), backup diaphragm (11), PTFE diaphragm (11A) & inner flange (5). Now pull out the half shaft assembly out of the shaft housing (1).

d. Now hold the shaft (7) in a vice with proper packing. Care must be taken not to damage the shaft outer surface. Now remove the outer flange (5) with spanner.

*For ALT/SST series remove the bolt (23) and remove the outer flange (5), Backup diaphragm (11) & PTFE diaphragm (11A).

e. Now replace the diaphragms (11). Ensure that diaphragm orientation is correct, i.e. For ALB/ALN/ALV the sticker side of the diaphragm (11) to be located in the outer chamber (6). Now assemble the outer flange (5) in reverse manner and remove the half shaft assembly from vice.

* For ALT & SST model the convex side of outer ring PTFE diaphragm (11A) to be located in outer chamber (6). For the backup diaphragm (11) the larger side of outer ring to be located in shaft housing (1) & small side in the concave groove of PTFE diaphragm (11A).

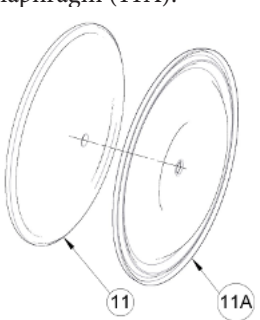

* For ALS/ ALH model AIR SIDE marking to be located towards the shaft housing (1).

f. Lubricate the edge of the shaft with specified lubricant. Slowly insert the shaft with rotating motion. Care should be taken not to damage the rubber rings (8).

g. Once the half shaft open portion comes out of the bush, follow the procedure in reverse manner as described in part (a) & (b) and assemble the pump.

2) Replacement of Shaft O rings

- a. For removing the rubber rings from bush, first follow the step a, b & c from the diaphragm replacement.
- b. Now remove the seals with the help of needle Nose pliers. Care should be taken not to damage the inner face of bush.
- c. Once all the old seals are have been removed, the inside of the bushing should be cleaned to ensure no debris is left that may damage to new seals (Pressurized air is preferable).
- d. These following tools can be used to aid in the installation of new seals:
 Needle Nose pliers
 Phillips Screwdriver
 Electrical Tape
- e. Wrap electrical tape around each leg of the needle

nose pliers (heat shrink may also be used) . This is done to prevent damaging the inside portion of the new seals.

f. With a new seal in hand, place the two legs of the nose pliers inside the seal ring. Open the pliers as wide as the seal diameter will allow, then two fingers pull down on the top portion of the seal to form kidney bean shape.

g. Lightly clamp the pliers together to hold the seal into the kidney shape. Be sure to pull the seal into as tight of a kidney shape as possible, this will allow the seal to travel down the bushing bore easier.

h. With the seal clamped in the pliers, insert the seal into the bushing bore and position the bottom of the seal into the correct groove. Once the bottom of the seal is seated in the groove, release the clamp pressure on the pliers. This will allow the seal to partially snap back to its original shape.

i. After the pliers are removed, you will notice a slight bump in the seal shape. Before the seal can be properly resized, the bump in the seal should be removed as much as possible. This can be done with either the Phillips screw driver or your finger, apply light pressure to the peak of the bump. This pressure will cause the bump to be almost completely eliminated.

j. Lubricate the edge of the shaft with specified lubricant.

k. Slowly insert the shaft with rotating motion. This will complete the resizing of the seals.

l. Perform these steps for the remaining seals.

3) Replacement of Ball seat & Ball

a) Follow the step (a) of diaphragm replacement. Replace the ball (12) & seat (13) with new one.

* For ALT, SST, ALS & ALH series change the valve seat (13) & oring (13A) with new one.

4) Replacement of air valve and o-ring of end cap

a) Unscrew nut (27) from the shaft housing (1). Remove the air valve assembly along with the bolt (24). Now remove the circlips (20) from both ends. Now with the help of bolt (24) pull the end cap (17) & (18) from both ends. Now slide out the air valve (16). Change the oring (19) of both end caps.

b) While assembly first put the end cap with pin (18) in air valve body (14). Make sure the notch of end cap (18) matches with the drill hole of body. Push the end cap with oring (19) gently. Now fit the circlip (20). Now slide the air valve from other side ensuring the drill portion located in the pin of end cap (18). Now push the end cap (17) with oring (19) from the other end.

c) You can also change the gasket for air valve body (14) & blocking pad (22). Now assemble the air valve assembly in reverse manner. While assembly make sure to put the spring washer (28) along with the nut (27).

Bill of Materials for TM25-ANX-REX-AXX Pump

ILLU. NO.	PART NO	DESCRIPTION	Qty
1	160 10 41	SHAFT HOUSING	1
2	160 10 02	INLET BASE	1
3	160 10 03	OUTLET	1
4	160 30 12	INNER FLANGE	2
5	160 10 05	OUTER FLANGE	2
6	160 10 04	OUTER CHAMBER SIDE	2
7	160 21 10	SHAFT	1
8	160 40 21	RUBBER RINGS	4
9	160 30 13	BIG CLAMP	4
10	160 30 14	SMALL CLAMP	8
11	160 40 20	DIAPHRAGM (NEOPRENE)	2
12	160 40 15	BALL (NEOPRENE)	4
13	160 40 16	SEAL (NEOPRENE)	4
14	163 04 01	AIR VALVE BODY	1
15	160 40 36	GASKET	1
16	163 20 01	AIR VALVE	1
17	160 08 03	VALVE END CAP	1
18	160 08 02	VALVE END CAP WITH PIN	1
19	163 40 01	O RING	2
20	160 90 25S	INT CIRCLIP	2
21	160 10 42	BLOCKING PAD	1
22	160 40 35	GASKET	1
23	160 21 09	STUD	2
24	160 90 51	ALLEN BOLT	4

ILLU. NO.	PART NO	DESCRIPTION	Qty
25	160 90 32	ALLEN BOLT	4
26	150 40 28	ALLEN BOLT	8
27	150 40 25	HEX NUT	12
28	500 90 48	SPRING WASHER	4
29	022 40 21	HEX NUT	4
30	200 97 15	SILENCER	1
25	160 90 32	ALLEN BOLT	4
26	150 40 28	ALLEN BOLT	8
27	150 40 25	HEX NUT	12
28	500 90 48	SPRING WASHER	4
29	022 40 21	HEX NUT	4
30	805 98 01	SILENCER	1

Note.

Above all parts are common for (NPT), (BSPT) & (BSPP) Pumps.
 The additional parts for (BSPT) & (BSPP) pumps model are as below

ITEM NO	PART NUMBER	DESCRIPTION	BSPT	BSPP
31	163 10 06	Adaptor 1" BSPT(F)	2	
31	163 10 09	Adaptor 1" BSPP(F)		2
32	171 04 03	Adaptor 1/4" BSPT(F)	1	
32	171 04 05	Adaptor 1/4" BSPP(F)		1

Exploded View for TM 25 Pump

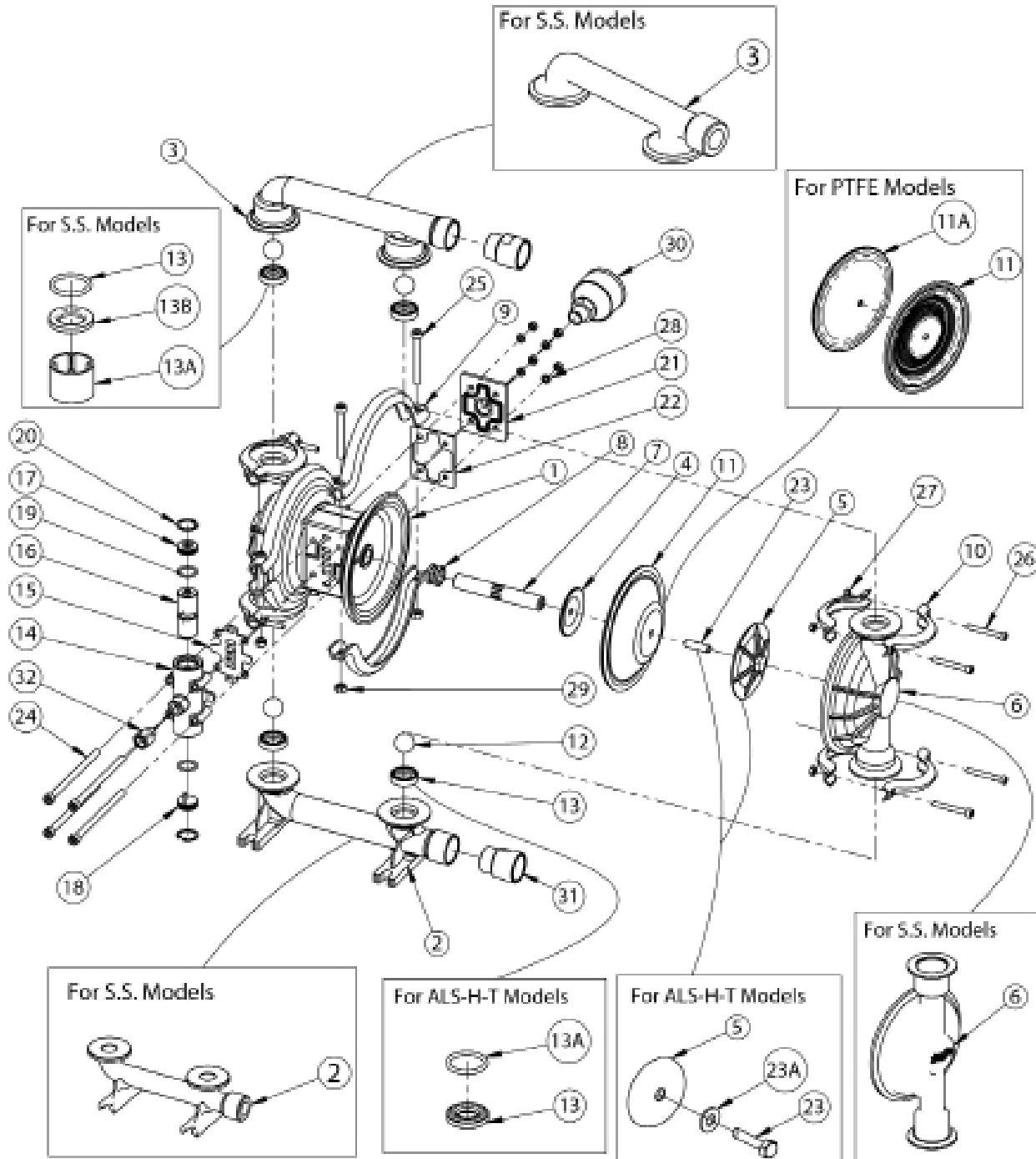

Bill of Materials for TM25-ABX-REX-AXX Pump

ILLU. NO.	PART NO	DESCRIPTION	Qty
1	160 10 41	SHAFT HOUSING	1
2	160 10 02	INLET BASE	1
3	160 10 03	OUTLET	1
4	160 30 12	INNER FLANGE	2
5	160 10 05	OUTER FLANGE	2
6	160 10 04	OUTER CHAMBER SIDE	2
7	160 21 10	SHAFT	1
8	160 40 21	RUBBER RINGS	4
9	160 30 13	BIG CLAMP	4
10	160 30 14	SMALL CLAMP	8
11	160 40 20B	DIAPHRAGM (BUNA N)	2
12	160 40 15B	BALL (BUNA N)	4
13	160 40 16B	SEAL (BUNA N)	4
14	163 04 01	AIR VALVE BODY	1
15	160 40 36	GASKET	1
16	163 20 01	AIR VALVE	1
17	160 08 03	VALVE END CAP	1
18	160 08 02	VALVE END CAP WITH PIN	1
19	163 40 01	O RING	2
20	160 90 25S	INT CIRCLIP	2
21	160 10 42	BLOCKING PAD	1
22	160 40 35	GASKET	1
23	160 21 09	STUD	2
24	160 90 51	ALLEN BOLT	4

ILLU. NO.	PART NO	DESCRIPTION	Qty
25	160 90 32	ALLEN BOLT	4
26	150 40 28	ALLEN BOLT	8
27	150 40 25	HEX NUT	12
28	500 90 48	SPRING WASHER	4
29	022 40 21	HEX NUT	4
30	200 97 15	SILENCER	1
25	160 90 32	ALLEN BOLT	4
26	150 40 28	ALLEN BOLT	8
27	150 40 25	HEX NUT	12
28	500 90 48	SPRING WASHER	4
29	022 40 21	HEX NUT	4
30	805 98 01	SILENCER	1

Note.

Above all parts are common for (NPT), (BSPT) & (BSPP) Pumps.
 The additional parts for (BSPT) & (BSPP) pumps model are as below

ITEM NO	PART NUMBER	DESCRIPTION	BSPT	BSPP
31	163 10 06	Adaptor 1" BSPT(F)	2	
31	163 10 09	Adaptor 1" BSPP(F)		2
32	171 04 03	Adaptor 1/4" BSPT(F)	1	
32	171 04 05	Adaptor 1/4" BSPP(F)		1

Bill of Materials for TM25-ASX-REX-AXX Pump

ILLU. NO.	PART NO	DESCRIPTION	Qty
1	160 10 41	SHAFT HOUSING	1
2	160 10 49	INLET BASE	1
3	1602712S	OUTLET	1
4	160 30 12	INNER FLANGE	2
5	160 10 05	OUTER FLANGE	2
6	160 10 48	OUTER CHAMBER SIDE	2
7	160 21 10	SHAFT	1
8	160 40 21	RUBBER RINGS	4
9	160 30 13	BIG CLAMP	14
10	160 30 14	SMALL CLAMP	8
11	163 41 01	DIAPHRAGM (SANTOPRENE)	2
12	163 41 02	BALL (SANTOPRENE)	4
13	160 20 51A	VALVE SEAT	4
13A	160 36 50T	O RING (PTFE)	4
14	163 04 01	AIR VALVE BODY	1
15	160 40 36	GASKET	1
16	163 20 01	AIR VALVE	1
17	160 08 03	VALVE END CAP	1
18	160 08 02	VALVE END CAP WITH PIN	1
19	163 40 01	O RING	2
20	160 90 25S	INT CIRCLIP	2
21	160 10 42	BLOCKING PAD	1
22	160 40 35	GASKET	1
23	160 21 09	STUD	2

ILLU. NO.	PART NO	DESCRIPTION	Qty
24	160 90 51	ALLEN BOLT	4
25	160 90 32	ALLEN BOLT	4
26	150 40 28	ALLEN BOLT	8
27	150 40 25	HEX NUT	12
28	500 90 48	SPRING WASHER	4
29	022 40 21	HEX NUT	4
30	200 97 15	SILENCER	1
26	150 40 28	ALLEN BOLT	8
27	150 40 25	HEX NUT	12
28	500 90 48	SPRING WASHER	4
29	022 40 21	HEX NUT	4
30	805 98 01	SILENCER	1

Note.

Above all parts are common for (NPT), (BSPT) & (BSPP) Pumps.
 The additional parts for (BSPT) & (BSPP) pumps model are as below

ITEM NO	PART NUMBER	DESCRIPTION	BSPT	BSPP
31	163 10 06	Adaptor 1” BSPT(F)	2	
31	163 10 09	Adaptor 1” BSPP(F)		2
32	171 04 03	Adaptor 1/4” BSPT(F)	1	
32	171 04 05	Adaptor 1/4” BSPP(F)		1

Bill of Materials for TM25-ATN-REX-AXX Pump

ILLU. NO.	PART NO	DESCRIPTION	Qty
1	160 10 41	SHAFT HOUSING	1
2	160 10 49	INLET BASE	1
3	160 10 03	OUTLET	1
4	160 30 12	INNER FLANGE	2
5	160 10 05	OUTER FLANGE	2
6	160 10 48	OUTER CHAMBER SIDE	2
7	160 21 10	SHAFT	1
8	160 40 21	RUBBER RINGS	4
9	160 30 13	BIG CLAMP	4
10	160 30 14	SMALL CLAMP	8
11	163 43 01	DIAPHRAGM (HYTREL)	2
12	163 43 02	BALL (HYTREL)	4
13	160 20 51A	VALVE SEAT	4
13A	160 36 50T	O RING (PTFE)	4
14	163 04 01	AIR VALVE BODY	1
15	160 40 36	GASKET	1
16	163 20 01	AIR VALVE	1
17	160 08 03	VALVE END CAP	1
18	160 08 02	VALVE END CAP WITH PIN	1
19	163 40 01	O RING	2
20	160 90 25S	INT CIRCLIP	2
21	160 10 42	BLOCKING PAD	1
22	160 40 35	GASKET	1
23	160 21 09	STUD	2

ILLU. NO.	PART NO	DESCRIPTION	Qty
24	160 90 51	ALLEN BOLT	4
25	160 90 32	ALLEN BOLT	4
26	150 40 28	ALLEN BOLT	8
27	150 40 25	HEX NUT	12
28	500 90 48	SPRING WASHER	4
29	022 40 21	HEX NUT	4
30	200 97 15	SILENCER	1
26	150 40 28	ALLEN BOLT	8
27	150 40 25	HEX NUT	12
28	500 90 48	SPRING WASHER	4
29	022 40 21	HEX NUT	4
30	805 98 01	SILENCER	1

Note.

Above all parts are common for (NPT), (BSPT) & (BSPP) Pumps.
 The additional parts for (BSPT) & (BSPP) pumps model are as below

ITEM NO	PART NUMBER	DESCRIPTION	BSPT	BSPP
31	163 10 06	Adaptor 1" BSPT(F)	2	
31	163 10 09	Adaptor 1" BSPP(F)		2
32	171 04 03	Adaptor 1/4" BSPT(F)	1	
32	171 04 05	Adaptor 1/4" BSPP(F)		1

Bill of Materials for TM25-SNX-REX-AXX Pump

ILLU. NO.	PART NO	DESCRIPTION	Qty
1	160 10 41	SHAFT HOUSING	1
2	163 07 01	INLET BASE	1
3	163 07 02	OUTLET	1
4	160 30 12	INNER FLANGE	2
5	160 27 05S	OUTER FLANGE	2
6	163 07 03	OUTER CHAMBER SIDE	2
7	160 21 10	SHAFT	1
8	160 40 21	RUBBER RINGS	4
9	160 30 13	BIG CLAMP	4
10	160 30 14	SMALL CLAMP	8
11	160 40 20	DIAPHRAGM (NEOPRENE)	2
12	160 40 15	BALL (NEOPRENE)	4
13	612 36 15T	O RING (PTFE)	4
13A	612 08 03	BALL CAGE	4
13B	612 36 13	BALL SEAT	4
14	163 04 01	AIR VALVE BODY	1
15	160 40 36	GASKET	1
16	163 20 01	AIR VALVE	1
17	160 08 03	VALVE END CAP	1
18	160 08 02	VALVE END CAP WITH PIN	1
19	163 40 01	O RING	2
20	160 90 25S	INT CIRCLIP	2
21	160 10 42	BLOCKING PAD	1
22	160 40 35	GASKET	1

ILLU. NO.	PART NO	DESCRIPTION	Qty
23	160 27 09	HEX. BOLT	2
23A	160 21 35	PLAIN WASHER	2
24	160 90 51	ALLEN BOLT	4
25	160 90 32	ALLEN BOLT	4
26	150 40 28	ALLEN BOLT	8
27	150 40 25	HEX NUT	12
28	500 90 48	SPRING WASHER	4
29	022 40 21	HEX NUT	4
30	200 97 15	SILENCER	1
28	500 90 48	SPRING WASHER	4
29	022 40 21	HEX NUT	4
30	805 98 01	SILENCER	1

Bill of Materials for TM25-SBX-REX-AXX Pump

ILLU. NO.	PART NO	DESCRIPTION	Qty
1	160 10 41	SHAFT HOUSING	1
2	163 07 01	INLET BASE	1
3	163 07 02	OUTLET	1
4	160 30 12	INNER FLANGE	2
5	160 27 05S	OUTER FLANGE	2
6	163 07 03	OUTER CHAMBER SIDE	2
7	160 21 10	SHAFT	1
8	160 40 21	RUBBER RINGS	4
9	160 30 13	BIG CLAMP	4
10	160 30 14	SMALL CLAMP	8
11	160 40 20B	DIAPHRAGM (BUNA N)	2
12	160 40 15B	BALL (BUNA N)	4
13	612 36 15T	O RING (PTFE)	4
13A	612 08 03	BALL CAGE	4
13B	612 36 13	BALL SEAT	4
14	163 04 01	AIR VALVE BODY	1
15	160 40 36	GASKET	1
16	163 20 01	AIR VALVE	1
17	160 08 03	VALVE END CAP	1
18	160 08 02	VALVE END CAP WITH PIN	1
19	163 40 01	O RING	2
20	160 90 25S	INT CIRCLIP	2
21	160 10 42	BLOCKING PAD	1
22	160 40 35	GASKET	1

ILLU. NO.	PART NO	DESCRIPTION	Qty
23	160 27 09	HEX. BOLT	2
23A	160 21 35	PLAIN WASHER	2
24	160 90 51	ALLEN BOLT	4
25	160 90 32	ALLEN BOLT	4
26	150 40 28	ALLEN BOLT	8
27	150 40 25	HEX NUT	12
28	500 90 48	SPRING WASHER	4
29	022 40 21	HEX NUT	4
30	200 97 15	SILENCER	1
28	500 90 48	SPRING WASHER	4
29	022 40 21	HEX NUT	4
30	805 98 01	SILENCER	1

Bill of Materials for TM25-SSX-REX-AXX Pump

ILLU. NO.	PART NO	DESCRIPTION	Qty
1	160 10 41	SHAFT HOUSING	1
2	163 07 01	INLET BASE	1
3	163 07 02	OUTLET	1
4	160 27 12S	INNER FLANGE SST	2
5	160 27 05S	OUTER FLANGE	2
6	163 07 03	OUTER CHAMBER SIDE	2
7	160 21 10	SHAFT	1
8	160 40 21	RUBBER RINGS	4
9	160 30 13	BIG CLAMP	4
10	160 30 14	SMALL CLAMP	8
11	163 41 01	DIAPHRAGM (SANTOPRENE)	2
12	163 41 02	BALL (SANTOPRENE)	4
13	612 36 15T	O RING (PTFE)	4
13A	612 08 03	BALL CAGE	4
13B	612 36 13	BALL SEAT	4
14	163 04 01	AIR VALVE BODY	1
15	160 40 36	GASKET	1
16	163 20 01	AIR VALVE	1
17	160 08 03	VALVE END CAP	1
18	160 08 02	VALVE END CAP WITH PIN	1
19	163 40 01	O RING	2
20	160 90 25S	INT CIRCLIP	2
21	160 10 42	BLOCKING PAD	1
22	160 40 35	GASKET	1

ILLU. NO.	PART NO	DESCRIPTION	Qty
23	160 27 09	HEX. BOLT	2
23A	160 21 35	PLAIN WASHER	2
24	160 90 51	ALLEN BOLT	4
25	160 90 32	ALLEN BOLT	4
26	150 40 28	ALLEN BOLT	8
27	150 40 25	HEX NUT	12
28	500 90 48	SPRING WASHER	4
29	022 40 21	HEX NUT	4
30	200 97 15	SILENCER	1
28	500 90 48	SPRING WASHER	4
29	022 40 21	HEX NUT	4
30	805 98 01	SILENCER	1

Bill of Materials for TM25-STN-REX-AXX Pump

ILLU. NO.	PART NO	DESCRIPTION	Qty
1	160 10 41	SHAFT HOUSING	1
2	163 07 01	INLET BASE	1
3	163 07 02	OUTLET	1
4	160 27 12S	INNER FLANGE SST	2
5	160 27 05S	OUTER FLANGE	2
6	163 07 03	OUTER CHAMBER SIDE	2
7	160 21 34	SHAFT ALT	1
8	160 40 21	RUBBER RINGS	4
9	160 30 13	BIG CLAMP	4
10	160 30 14	SMALL CLAMP	8
11	160 40 33N	BACKUP DIAPHRAGM	2
11A	160 36 20T	DIAPHRAGM (PTFE)	2
12	160 36 15T	BALL (PTFE)	4
13	612 36 15T	O RING (PTFE)	4
13A	612 08 03	BALL CAGE	4
13B	612 36 13	BALL SEAT	4
14	163 04 01	AIR VALVE BODY	1
15	160 40 36	GASKET	1
16	163 20 01	AIR VALVE	1
17	160 08 03	VALVE END CAP	1
18	160 08 02	VALVE END CAP WITH PIN	1
19	163 40 01	O RING	2
20	160 90 25S	INT CIRCLIP	2
21	160 10 42	BLOCKING PAD	1

ILLU. NO.	PART NO	DESCRIPTION	Qty
22	160 40 35	GASKET	1
23	160 27 09	HEX. BOLT	2
23A	160 21 35	PLAIN WASHER	2
24	160 90 51	ALLEN BOLT	4
25	160 90 32	ALLEN BOLT	4
26	150 40 28	ALLEN BOLT	8
27	150 40 25	HEX NUT	12
28	500 90 48	SPRING WASHER	4
29	022 40 21	HEX NUT	4
30	200 97 15	SILENCER	1
29	022 40 21	HEX NUT	4
30	805 98 01	SILENCER	1

Dimensional Data

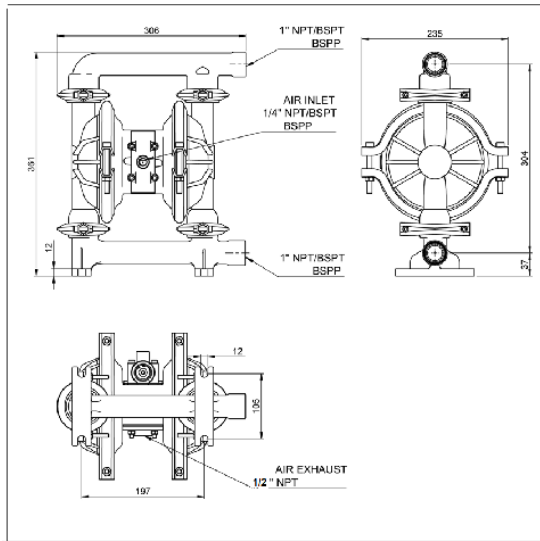

TM25 ALX

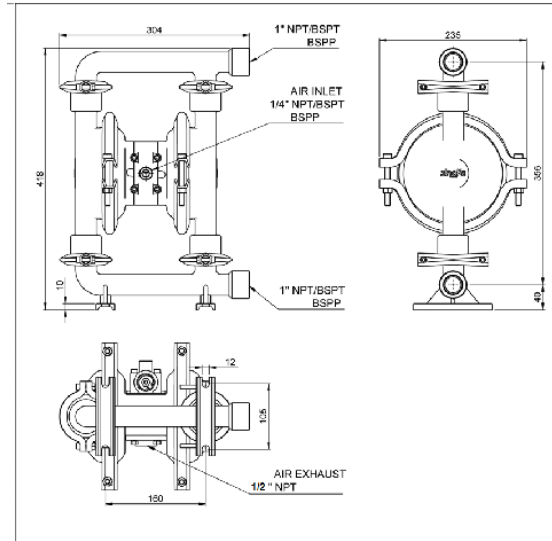

TM25 SSX

Air Valve Replacement Kits For ALX / SSX

Replacement KIT Ordering No	Suitable for
163 97 03	NPT Fitted ALX or SSX Pumps With Any Diaphragm Variant
163 97 04	BSPT Fitted ALX or SSX Pumps With Any Diaphragm Variant
163 97 05	BSPP Fitted ALX or SSX Pumps With Any Diaphragm Variant

Repair Kits for ALX Pumps

Repair KIT Ordering No	Suitable for
163 97 06N	TM25 ANX
163 97 06B	TM25 ABX
163 97 06S	TM 25 ASX
163 97 06T	TM25 ATN

Repair Kits for SSX Pumps

Repair KIT Ordering No	Suitable for
163 97 06SN	TM25 SNX
163 97 06SB	TM25 SBX
163 97 06SS	TM25 SSX
163 97 06ST	TM25 STN

Repair and Replacement Kits

Illu. No.	Part No.	Description	NPT	BSPT	BSPP	ALX Pumps				SSX Pumps			
			1639703 replacement Kit	1639704 replacement kit	1639705 replacement kit	Repair Kit 1639706B	Repair Kit 1639706N	Repair Kit 1639706S	Repair Kit 1639706T	Repair Kit 1639706SB	Repair Kit 1639706SN	Repair Kit 1639706SS	Repair Kit 1639706ST
8	160 40 21	RUBBER RINGS				4	4	4	4	4	4	4	4
11	160 40 20B	DIAPHRAGM (BUNA N)				2				2			
11	160 40 20	DIAPHRAGM (NEOPRENE)					2				2		
11	163 41 01	DIAPHRAGM (SANTOPRENE)						2				2	
11	160 40 33N	BACKUP DIAPHRAGM							2				2
11A	160 36 20T	DIAPHRAGM (PTFE)							2				2
12	160 40 15B	BALL (BUNA N)				4				4			
12	160 40 15	BALL (NEOPRENE)					4				4		
12	163 41 02	BALL (SANTOPRENE)						4				4	
12	160 36 15T	BALL (PTFE)							4				4
13	160 40 16B	SEAL (BUNA N)				4							
13	160 40 16	SEAL (NEOPRENE)					4						
13	160 20 51A	VALVE SEAT						4	4				
13A	160 36 50T	O RING (PTFE)						4	4				
13	612 36 15T	O RING (PTFE)								4	4	4	4
13A	612 08 03	BALL CAGE								4	4	4	4
13B	612 36 13	BALL SEAT								4	4	4	4
14	163 04 01	AIR VALVE BODY	1	1	1								
15	160 40 36	GASKET	1	1	1	1	1	1	1	1	1	1	1
16	163 20 01	AIR VALVE	1	1	1	1	1	1	1	1	1	1	1
17	160 08 03	VALVE END CAP	1	1	1	1	1	1	1	1	1	1	1
18	160 08 02	VALVE END CAP WITH PIN	1	1	1	1	1	1	1	1	1	1	1
19	163 40 01	O RING	2	2	2	2	2	2	2	2	2	2	2
20	160 90 25S	INT CIRCLIP	2	2	2	2	2	2	2	2	2	2	2
22	160 40 35	GASKET	1	1	1	1	1	1	1	1	1	1	1
24	160 90 51	ALLEN BOLT	4	4	4								
27	150 40 25	HEX NUT	4	4	4								
28	500 90 48	SPRING WASHER	4	4	4								
32	171 04 03	Adaptor 1/4" BSPT(F)		1									
32	171 04 05	Adaptor 1/4" BSPP(F)			1								

EU DECLARATION OF CONFORMITY

Object of declaration

PRODUCT : AIR OPERATED DOUBLE DIAPHRAGM PUMP
MODEL : TM 25 Series
MANUFACTURER'S NAME : TERYAIR EQUIPMENT PVT. LTD.
ADDRESS : SITE - 1 : BUILDING A - 1/2, 102 TO 105 & BUILDING C 12 & 13,
 TIRUPATI UDYOG NAGAR, SATIVALI ROAD, VASAI (E),
 PALGHAR: 401208.
 SITE - 2: AUGUSTINE - II, COLACO INDUSTRIAL COMPLEX,
 GALA NO - 101 TO 107, SATIVALI ROAD, VILLAGE WALIV,
 VASAI (E), PALGHAR: 401208

To provide presumption of conformity in order to directive 2014/34/EU; the following harmonized standards and/or other normative documents as referenced within the following official journals are applied:

APPLICABLE DIRECTIVE: ATEX DIRECTIVE (2014/34/EU)

APPLICABLE STANDARDS:

EN ISO 80079-36: 2016 : Explosive atmospheres —Part 36: Non-electrical equipment for explosive atmospheres —Basic method and requirements.
EN ISO 80079-37:2016 : Explosive atmospheres —Part 37: Non-electrical equipment for explosive atmospheres —Non- electrical type of protection constructional safety 'c', control of ignition sources 'b', liquid immersion 'k'.

Notified body to whom Technical file has logged with: - Technicka Inspekcia (Ref: 1354).

DECLARATION: - TERYAIR EQUIPMENT PVT. LTD., declare that under our sole responsibility for the supply of the product defined above, the said product complies with all the applicable Directives, Regulations and all essential Health and Safety requirements applying to it.

I, the undersigned, hereby declare that the product specified above conforms to the above standard(s).

ATEX MARKING APPLIED



Please Refer ATEX Rating for **Teryair Aodd Models Table**

Signed for and on behalf of

TERYAIR EQUIPMENT PVT. LTD.

Place of Issue : Vasai

SUMMARY FOR THE ATEX RATING FOR TERYAIR AODD MODELS

Pump Size	Series	Wetted Materials	Center Section	Dipharagm Materials	ATEX Rating
06 (1/4")	TP	Aluminium	Aluminium	Neoprene	II 2 GD Ex h IIC T6 Gb Ex h IIIC T85°C Db (IP65)
				Buna-N	
				Sentoprene	II 2 GD Ex h IIC T5 Gb Ex h IIIC T100°C Db (IP65)
				PTFE	
		Stainless Steel	Stainless Steel	Neoprene	II 2 GD Ex h IIC T6 Gb Ex h IIIC T85°C Db I M2 Ex h I Mb (IP65)
				Buna-N	
Sentoprene	II 2 GD Ex h IIC T5 Gb Ex h IIIC T100°C Db (IP65)				
PTFE					
12 (1/2")	TM / TP	Aluminium	Aluminium	Neoprene	II 2 GD Ex h IIC T6 Gb Ex h IIIC T85°C Db (IP65)
				Buna-N	
				Sentoprene	II 2 GD Ex h IIC T5 Gb Ex h IIIC T100°C Db (IP65)
				PTFE	
	TP	Stainless Steel	Stainless Steel	Neoprene	II 2 GD Ex h IIC T6 Gb Ex h IIIC T85°C Db I M2 Ex h I Mb (IP65)
				Buna-N	
				Sentoprene	II 2 GD Ex h IIC T5 Gb Ex h IIIC T100°C Db (IP65)
				PTFE	
25 (1")	TM / TP	Aluminium / Stainless Steel	Aluminium	Neoprene	II 2 GD Ex h IIC T6 Gb Ex h IIIC T85°C Db (IP65)
				Buna-N	
				Sentoprene	II 2 GD Ex h IIC T5 Gb Ex h IIIC T100°C Db (IP65)
				PTFE	
40 (1-1/2")	TM / TP	Aluminium / Stainless Steel	Aluminium	Neoprene	II 2 GD Ex h IIC T6 Gb Ex h IIIC T85°C Db (IP65)
				Buna-N	
				Sentoprene	II 2 GD Ex h IIC T5 Gb Ex h IIIC T100°C Db (IP65)
				PTFE	
50 (2")	TM / TP	Aluminium / Stainless Steel	Aluminium	Neoprene	II 2 GD Ex h IIC T6 Gb Ex h IIIC T85°C Db (IP65)
				Buna-N	
				Sentoprene	II 2 GD Ex h IIC T5 Gb Ex h IIIC T100°C Db (IP65)
				PTFE	
75 (3")	TM / TP	Aluminium	Aluminium	Neoprene	II 2 GD Ex h IIC T6 Gb Ex h IIIC T85°C Db (IP65)
				Buna-N	
				Sentoprene	II 2 GD Ex h IIC T5 Gb Ex h IIIC T100°C Db (IP65)
				PTFE	



Warranty Certificate

Every product manufactured by Teryair
is built to meet the highest standards of quality.

Teryair warrants that the Products, accessories and parts manufactured or supplied by the company be free from defects in material and workmanship for a period of six months from date of Teryair authorized dealer invoice to customer, or one year from date of Teryair invoice to dealer, whichever is earlier. Failure due to normal wear, misapplication, or abuse is, of course, excluded from this warranty.

Since the use of Teryair products and parts is beyond our control, Teryair cannot guarantee the suitability of any product or part for a particular application and Teryair shall not be liable for any consequential damage or expense arising from the use or misuse of its products on any application. Teryair does not warranty bought out products or components such as electric motors and hardware but will assist in directing warranty queries to the dealer/manufacturer responsible. Teryair responsibility is limited solely to replacement or repair of defective Teryair products or components.

Dealer/End User shall have no right or remedy and Teryair shall have no liability or obligation under the warranty, if: (i) a Product is altered, changed, modified or tampered with in any way; (ii) a Product is damaged after deposit with the transporter for shipment; (iii) a Product is not properly preserved, packaged, stored, processed or handled after receipt; (iv) a Product is not used and maintained in accordance with Teryair's recommended operating and maintenance manuals, instructions and procedures, if any; (v) a Product is not properly incorporated or installed in, or not properly combined with, an Other Product; (vi) the issue with a Product is directly or indirectly attributable to, or directly or indirectly results from or arises out of, a failure, substandard performance or other issue with another product, material, component or part not supplied by Teryair; (vii) the issue with a Product is directly or indirectly attributable to, or directly or indirectly results from or arises out of, compliance with any design, specification or other specific requirement of Dealer/End User; (viii) a Product is used in a manner, with a substance or for a purpose other than the normal manner, substance and purpose for which it is intended or is otherwise subjected to abnormal use or service; (ix) a Product is subjected to a power surge, brown out or other similar occurrence; (x) the issue with a Product is directly or indirectly attributable to, or directly or indirectly results from or arises out of, normal wear and tear of such Product (including, without limitation, things such as worn seals, diaphragms, balls, O rings, gaskets, chisels, cutters, hoses and other such wearing components; (xi) the issue with a Product is directly or indirectly.

A handwritten signature in blue ink, appearing to read "M. Yadav", is written over a horizontal line.

M. Yadav, Q.A. Manager

(Company Seal)