

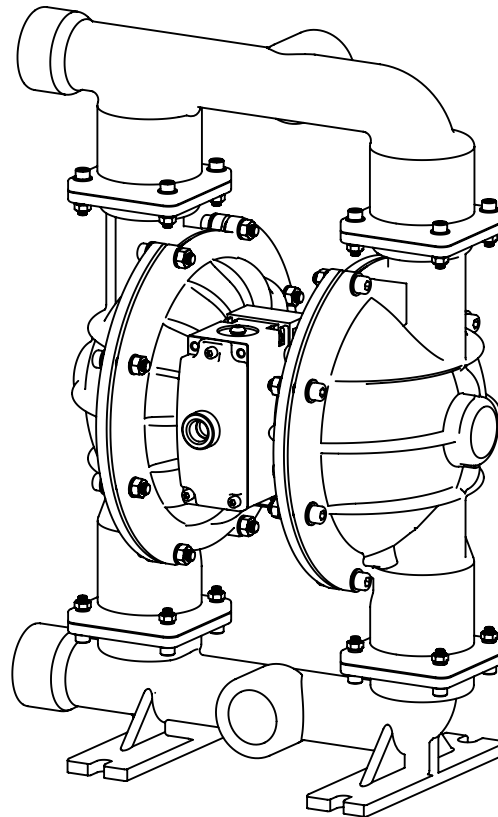

Operation and Maintenance Guide



TP50 Stainless Steel Pump Series

Models	Descriptions
TP50-SSX-REX-AXX	Teryair 2" Diaphragm Pump TeryPro Stainless Steel Santoprene NPT End Port / ATEX
TP50-STS-REX-AXX	Teryair 2" Diaphragm Pump TeryPro Stainless Steel PTFE-Santoprene NPT End Port / ATEX
TP50-SBX-REX-AXX	Teryair 2" Diaphragm Pump TeryPro Stainless Steel Buna NPT End Port / ATEX

Read this manual carefully before installing, operating or servicing this equipment. It's the responsibility of the employer to ensure this manual is read by the operator. Please preserve this manual.

Table of Contents

3	Pump Nomenclature
3	Operating and Safety instructions
4	Operating Instructions
5	Suggested Lubricants
6	Suggested site selection and installation recommendations
7	Troubleshooting
8	Maintenance
8	Diassembly and Re-assembly
11	Re-Assembly
12	Exploded View for TP50 Pump
13	Bill of Materials for TP50 ALX Pump
14	Bill of Materials for TP50 SSX Pump
15	Replacement & Repair Kits for TP50ALX / SSX Pump
16	Dimensional Data
17	Eu Declaration Of Conformity
18	Summery For The Atex Rating For Teryair Aodd Models
20	Warranty Certificate

Pump Nomenclature

Position	1	2	3	4	5	6	7	8	9	10	11
Example:	TP	15	A	B	X	R	E	X	A	X	X
Example: TP25-ABX-GEX-AXX											
Position 1 Range	Position 2 Size	Position 3 Body	Position 4 Diaphragm/ Valve	Position 5 Back Up	Position 6 Port	Position 7 Port Position	Position 8 Speciality Code	Position 9 Safety Code	Position 10 Sanitary Code	Position 11 Speciality Code	
TP- Industrial	15 - ½" 25 - 1" 40 - 1-½" 50 - 2"	A - Aluminium S - Stainless Steel	B - Buna (Nitrile) T - PTFE S - Santoprene	S - Santoprene X - None	G - BSPT C - TriClamp BS 4825-3 F - Flanged ANSI/DIN R - NPT P - BSPP	C - Centre Ported, End Port Plugged E - End Ported	P - Pulse Dampener R - Remote Solenoid Driven T - Trolley Mounted X - None	A - ATEX/ IECEx	F - FDA / EN 1935/2004 X - None	S - Speed Controller C - Cycle Counter D - Diaphragm Monitoring X - None O - See foot note	

Foot note: Centre Port Horizontal, Center Port Vertical and End Port on Inlet and Outlet are all threaded and plugged. Pump is blue Painted, and comes with Brass Silencer
This is available only in 1/2" Aluminium for Paint Spray Application

Operating and Safety Instructions

Warning: Static Electricity

- Static sparks can cause explosion resulting in severe injury or death.
- Ground the pump and the pump connections like hoses and containers into which or from the fluid is being transferred. Connect the grounding wire to any bolt on the pump.
- Check continuity of electrical path to ground at regular intervals.
- Consult local building and electrical codes for grounding requirements where needed.
- Use hoses containing a grounding wire.

Warning: Pump Exhaust

In case of a diaphragm failure, fluid being pumped may spray out from the exhaust of the pump. This may cause severe injury depending on the fluid being pumped.

If the fluid is hazardous, pipe away the exhaust to a safe remote location using a generous diameter pipe preferably with a grounding arrangement, and refit the muffler at the end of this arrangement.

Always wear safety glasses while in the vicinity of an operating pump.

Warning: Over pressure / Hazardous Pressure

Do not exceed the max supply air pressure of 100 PSI.

Make sure all connected hoses and pipelines are rated to operate safely with the pressures generated by pump of 100 PSI.

Do not open or handle pump or hoses while pressurized.

Disconnect air supply line and relieve pressure from the system by carefully opening discharge and supply lines.

Warning: Hazardous Materials

Do not move a pump that contains hazardous fluids trapped inside it. Please observe prescribed handling and safety codes. Drain the pump safely, by turning it upside down and collecting the fluid safely, before moving the pump.

Warning: Explosion

Please check compatibility of fluids intended to be handled with the materials of construction of the pump. Severe reactions and explosions may occur if materials are incompatible.

 **Caution: Chemical compatibility**

Please check that the fluid being pumped is compatible with the wetted parts of the pump. Re-fer Cole Parmer compatibility (<http://www.coleparmer.in/Chemical-Resistance>) guide for de-tails. Note that chemical compatibility may change with temperature; take this into account while selecting pump material.

 **Caution: Structural support**

Please refer figure 1 and ensure that the piping system is independently supported and does not load the pump. The pumps are not designed to take the continuous and often pulsating load of a piping system. Important to use a flexible connection between rigid piping and pump casings.

 **Caution: Running dry, disconnection of hoses when not in use**

Although these pumps can be run dry for long periods, it is advisable to avoid this as it causes unnecessary wear of wearing parts

 **Caution: Operator understanding**

Please ensure that all operators have read this manual and have the required understanding of safe working practices and are equipped with safety equipment when working on/around the pump.



 **Caution: Using genuine teryair fittings & spares**

Use genuine teryair parts to ensure correct pump operation and maximize life.

Operating Instructions

- The Teryair diaphragm pump generates a alternate stroking of the diaphragms against the fluid in the liquid chambers of the Pump. This reciprocatory action is responsible for the fluid being pumped.
- It is possible to control the output of the pump by controlling the supply air pressure.
- It is also possible to control the output of the pump by throttling action on the fluid flowing in the outlet piping by means of a valve. if such a valve is shut completely the pressure in the discharge piping increases to a point when the pressure at pump discharge equals it and the pump comes to a stop. This causes no damage to the pump and the pump consumes no more energy.
- Upon opening of the valve, the pump starts reciprocating once again and resumes fluid delivery.

 **Caution: Temperature limitations and diaphragm options**

<p>Santoprene</p>		<p>Good abrasion resistance. Low cost. Can handle mild acids and alkalis well. Excellent low cost alternative to ptfе. Excellent suction capabilities Excellent general purpose diaphragm. Temperature range -40°C to +107°C (-40F to +225°F)</p>
<p>PTFE</p>		<p>Excellent choice when pumping highly aggressive fluids such as aromatic or chlorinated hydrocarbons, acids, caustics, ketones and acetates. Temperature range +4°C to +104°C (+40°F to +220°F)</p>

Suggested Lubricants

Brand	Above 27 Deg C (From 5 Deg C to 27 Deg C	Below 5 Deg C
Shell	Toona R 72	Toona R 41	Toona R 27
Mobil	Almo 529	Almo 527	Almo 525
Esso	- - - -	Arox EP 65	Arox EP 45
Caltex	Rando Oil 150	Rando Oil 100	Rando Oil 46
Texaco	Regal Oil F	Regal Oil PE	Regal Oil B
Daltron	Silkolene 881	Silkolene 548	Silkolene 773
Burmah Castrol	RD Oil 3	RD Oil Light	Megna SPX
BP	RD 220 HP60C	RD150 HP20C	RD80 HP10C
Duckham	Garnet 7	Garnet 6	Zero Flo 5
Sternol	Merlin 87	Merlin 71	Merlin 54
Petrofina	Purifoc 53	Purifoc 46	Purifoc 32
Chevron	Vistac Oil 18X	Vistac Oil 19X	Vistac Oil 9X

Suggested site selection and installation recommendations

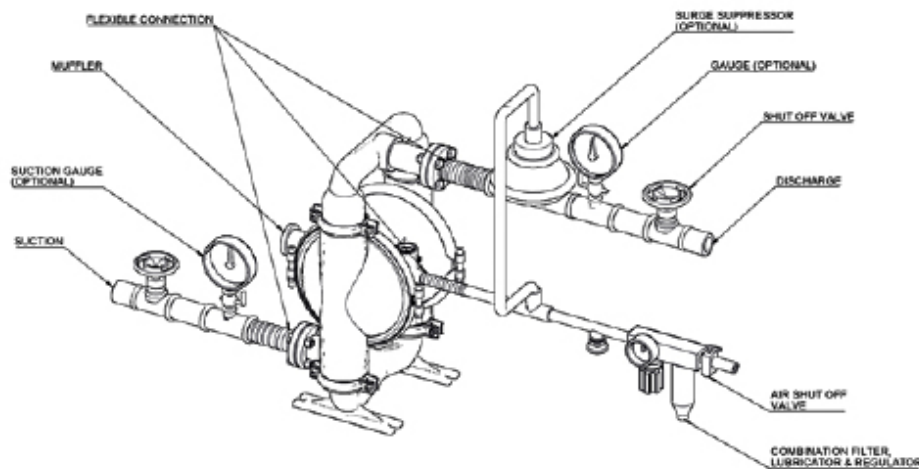

Figure 1

Location selection

Pump location must be easily accessible with reasonable space around for maintenance operations. Pump dimensional data for each variant is available in section showing exploded views

Air supply

Compressed air at 90 PSI (Stroke pumps can take a max of 100PSI), free from moisture and having an oil mist is essential. Use of a filter (50 microns), a lubricator and a regulator is highly recommended and should be installed as close as possible to the pump inlet.

Ensure correct grade of oil is used in the lubricator bowl. Too thick oil may slow down the valve shifting mechanism and affect pump performance. See suggested lubricants on page no 5.

Piping

A minimum number of bends and fittings to be used.

A flexible connection between suction, delivery and air supply piping is highly recommended such that piping stresses and loads do not transfer to pump housing. Select piping materials such that chemical compatibility is maintained with the fluid being pumped.

Suction

Ensure that the suction head after installation is well within the pumps suction capabilities

Muffler

Use of supplied muffler is recommended to bring pump operation sounds down to comfortable levels, in case of hazardous fluids handling, please read section of safety regarding piping away of exhaust see

Warning: Pump Exhaust) earlier in this manual.

Troubleshooting

Serial No	Description	Causes	Remedial Action
1	Pump stops and will not start	Insufficient Air Pressure	Check air pressure is as recommended at the pump air inlet
		Air Filter Blocked	Check if debris has clogged the inlet filter on the FRL unit/pump inlet air valve (some models have air filter on the air inlet valve) and ensure clear passage of air
		Internal damage or excessive wear on components	Proceed to dismantle the pump, examine component for wear, replace any worn components, re assemble carefully as instructed in this manual and re start the pump.
2	Pumps runs slowly, poor delivery	Cavitation	Check if cavitation is occurring in the suction side, if so reduce suction vacuum by slowing down the pump.
		Worn Balls and Seats	Check proper sealing action of balls against seals, these components need to be replaced as a set if they are worn.
		Insufficient or wrong lubricant in the air supply.	Ensure that the lubricant is as per the recommended chart, a thicker lubricant often makes the air valve work sluggishly
		Internal damage or excessive wear on components	Proceed to dismantle the pump, examine component for wear, replace any worn components, re assemble carefully as instructed in this manual and re start the pump.
3	Pump air valve freezes	Excessive moisture in supply air line.	Ensure that the dew point of the supplied air is low enough. Install a air dryer or moisture separator on the supply line
4	Air bubbles in pump discharge or product sprays out of exhaust vent	Broken Diaphragm	Proceed to dismantle the pump, examine component for wear, replace any worn components, re assembly carefully as instructed in this manual and re start the pump
		Improper seal between inner pistons, outer pistons and shaft.	
		Air leakage into product from balls / seats area	
		Air sucked into suction pipeline due to insufficiently tight joints on suction pipeline.	

Maintenance

Regular inspection and maintenance schedules will greatly enhance the life of the pump and will ensure a trouble free and safe working environment with little chance of breakdowns.

Follow the instructions clearly in “Disassembly and Reassembly” of the pump and in the troubleshooting section.

Use genuine Teryair spares and if possible mention the serial number of the pump when ordering spares.

Disassembly and Re-assembly

- Shut off air supply and allow residual Pressure to bleed off.
- Disconnect air supply
- Disconnect suction and discharge piping
- Turn pump upside down allow process fluid to drain away. If fluid is hazardous due care should be taken.
- Make a mark to indicate the positioning of each liquid chamber relative to the housing.
- NOTE: Replace worn parts with genuine Teryair parts for reliable performance.

1. Replacement of Ball Seat & Ball

- a. Unscrew both bolt (12) & plain washer (13), as shown in the exploded view and proceed to remove the outlet (3) & inlet base (2) respectively.
- b. Now replace the ball (10) & ball seat (11).
- c. In case of PTFE Model replace the o ring (11A)

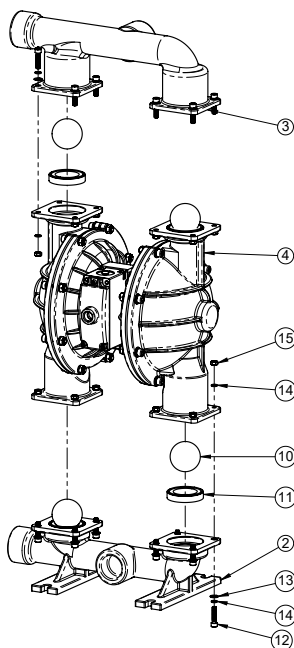

2. Replacement of Diaphragm

- a. Follow the step a and b of replacement of ball seat and ball.
- b. Now unscrew hex socket head bolt (16), spring washer (18) & plane washer (17) of any one side and proceed to remove the outer chamber (4). Now repeat the same procedure to remove the second outer chamber.

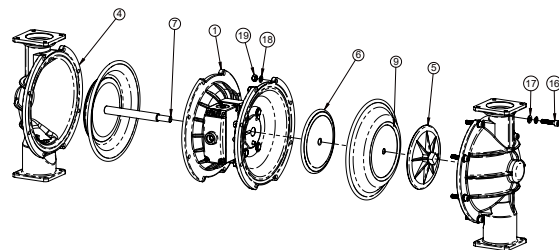

- c. Now with the help of two spanner hold one of the across flat of one outer flange (5) and rotate the second outer flange (5) to disassemble it from the shaft assembly. Remove the diaphragm (9), inner flange (6).
- d. Now pull out the half shaft assembly out of the shaft housing (1). Now hold the shaft (14) in a vice with proper packing. Care must be taken not to damage the shaft outer surface. Now remove the outer flange (5) with spanner.
- e. Now replace the diaphragms (9). Ensure that diaphragm orientation is correct. In case of PTFE, make sure PTFE side of diaphragm faces outer chamber (4).
*In case of Santoprene, make sure the convex side Santoprene diaphragm faces outer chamber (4).

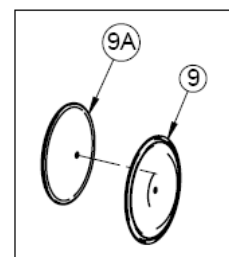

3. Replacement of Shaft Seals

- a. For removing the rubber rings from centre piece, first follow the steps a, b c & d from the diaphragm replacement.
- b. Now remove the seals (8) with the help of needle Nose pliers. Care should be taken not to damage the inner face of bush.
- c. Once all the old seals are have been removed, the inside of the centre piece should be cleaned to ensure no debris is left that may damage to new seals (Pressurized air is preferable).
- d. Wrap electrical tape around each leg of the needle nose pliers (heat shrink may also be used) . This is done to prevent damaging the inside portion of the new seals.
- e. With a new seal in hand, place the two legs of the nose pliers inside the seal ring. Open the pliers as wide as the seal diameter will allow, then two fingers pull down on the top portion of the seal to form kidney bean shape. (Refer Fig. A)
- f. Lightly clamp the pliers together to hold the seal into the kidney shape. Be sure to pull the seal into as tight of a kidney shape as possible, this will allow the seal to travel down the centre piece bore easier. (Refer Fig. B)
- g. With the seal clamped in the pliers, insert the seal into the bushing bore and position the bottom of the seal into the correct groove. Once the bottom of the seal is seated in the groove, release the clamp pressure on the pliers. This will allow the seal to partially snap back to its original shape.
- h. After the pliers are removed, you will notice a slight bump in the seal shape. Before the seal can be properly re-sized, the bump in the seal should be removed as much as possible. This can be done with either the Phillips screw driver or your finger, apply light pressure to the peak of the bump.
- i. This pressure will cause the bump to be almost completely eliminated.
- j. Lubricate the edge of the shaft with specified lubricant.
- k. Slowly insert the shaft with rotating motion. This will complete the re-sizing of the seals.
- l. Perform these steps for the remaining seals.

Air Valve/ Center Section Disassembly

4. Replacement Of Secondary Shaft Assembly

- a. For removing the secondary shaft assembly from center piece assembly, first follow the steps a, b, c, d from the diaphragm replacement and remove the outer chamber (4).
- b. Repeat the same procedure to remove the other side also.
- c. Now push the secondary shaft assembly (43) one side of shaft housing (1) and remove the end Orings (43b) from Secondary shaft assembly (43).
- d. Now if you see there is a center drill mark on one side of the secondary shaft assembly (43). Pull the secondary shaft assembly from that side only.
- e. During assembly make sure to push the secondary shaft assembly (43) from the plain side only into the sleeve (20).

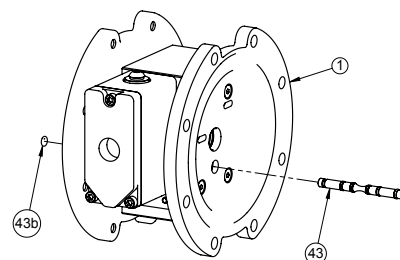

5. Replacement of Air Valve, Gasket, O-Rings of End Cap & Piston

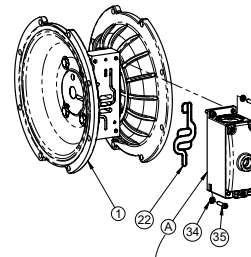

- a. Unscrew Allen bolts (41) & plain washer (42) from shaft housing (1) and remove Air valve Assly (A) from housing (1). Now remove the gasket (22) from Air valve Assly (A). While re-assembling replace gasket (22) with new one.
- b. Remove the circlip (40) with the help of a circlip opener. Remove the end cap metal cover (39) and now use a M6 Bolt to pull the end cap (37) with its O-ring (38) out of the air valve body (23).

(Note - Ensure that the metal cover is always installed with an end cap (37))

- c. Use the same bolt to pull the air piston assembly (34) with all its seals. This piston assembly (34) needs to replace as a single piece.
- d. In order to remove the differential cap assly (35) with its seals, remove the screw (31) with spring washer (32) and plan washer (33) by using allen key and push it to remove. Differential cap assly (35) also needs to be replaced with seals.
- e. Now remove O-ring (29c) from End cap (29a) and replace it with new one.

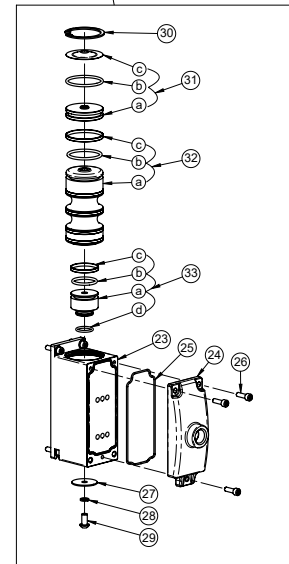

- f. Unscrew the Allen screw (28) using suitable key. Open cover (26) & replace O-ring (27) with new one.

Re-Assembly

Upon performing applicable maintenance to the air distribution system, the pump can now be reassembled. Please refer to the dis-assembly instructions for photos and parts placement. To reassemble the pump, follow the dis-assembly instructions in reverse order. The air distribution system needs to be assembled first, then the Diaphragms and finally the wetted path. Please find the applicable torque specifications on this page.

The following tips will assist in the assembly process.

- a. Clean the inside of the center section shaft bore to ensure no damage is done to new seals.
- b. Stainless bolts should be lubed to reduce the possibility of seizing during tightening.
- c. Level the water chamber side of the intake/discharge manifold to ensure a proper sealing surface. This is most easily accomplished by placing them on a flat surface prior to tightening their clamp bands to the desired torque (see below for Torque Specifications).
- d. Be sure to tighten outer pistons simultaneously on PTFE-fitted pumps to ensure proper torque values.
- e. Ensure proper mating of liquid chambers to manifolds prior to tightening vertical bolts. Overhang should be equal on both sides.
- f. Apply a small amount of Loctite 242 to the shaft interval threads before the diaphragm assembly.
- g. Concave side of disc spring in diaphragm assembly faces toward shaft.

MAXIMUM TORQUE SPECIFICATIONS (SDP25)

DESCRIPTION OF PART	TORQUE
Air Valve	5.1 N•m (45 in-lb)
Air Chamber/Center Block	47.5 N•m (35 ft-lb)
Outer Flanges, Rubber & PTFE, Excluding Stainless Steel Inner Pistons	106 N•m (78 ft-lb)
Outer Flanges, Rubber & PTFE, Stainless Steel Inner Pistons	119 N•m (88 ft-lb)
Outer Flanges, Ultra-Flex™	74.6 N•m (55 ft-lb)
Small Clamp Bands	6.6 N•m (58 in-lb)
Large Clamp Bands (Rubber-Fitted)	47.5 N•m (35 ft-lb)
Large Clamp Bands (PTFE-Fitted)	47.5 N•m (35 ft-lb)

Exploded View for TP 50 Pump

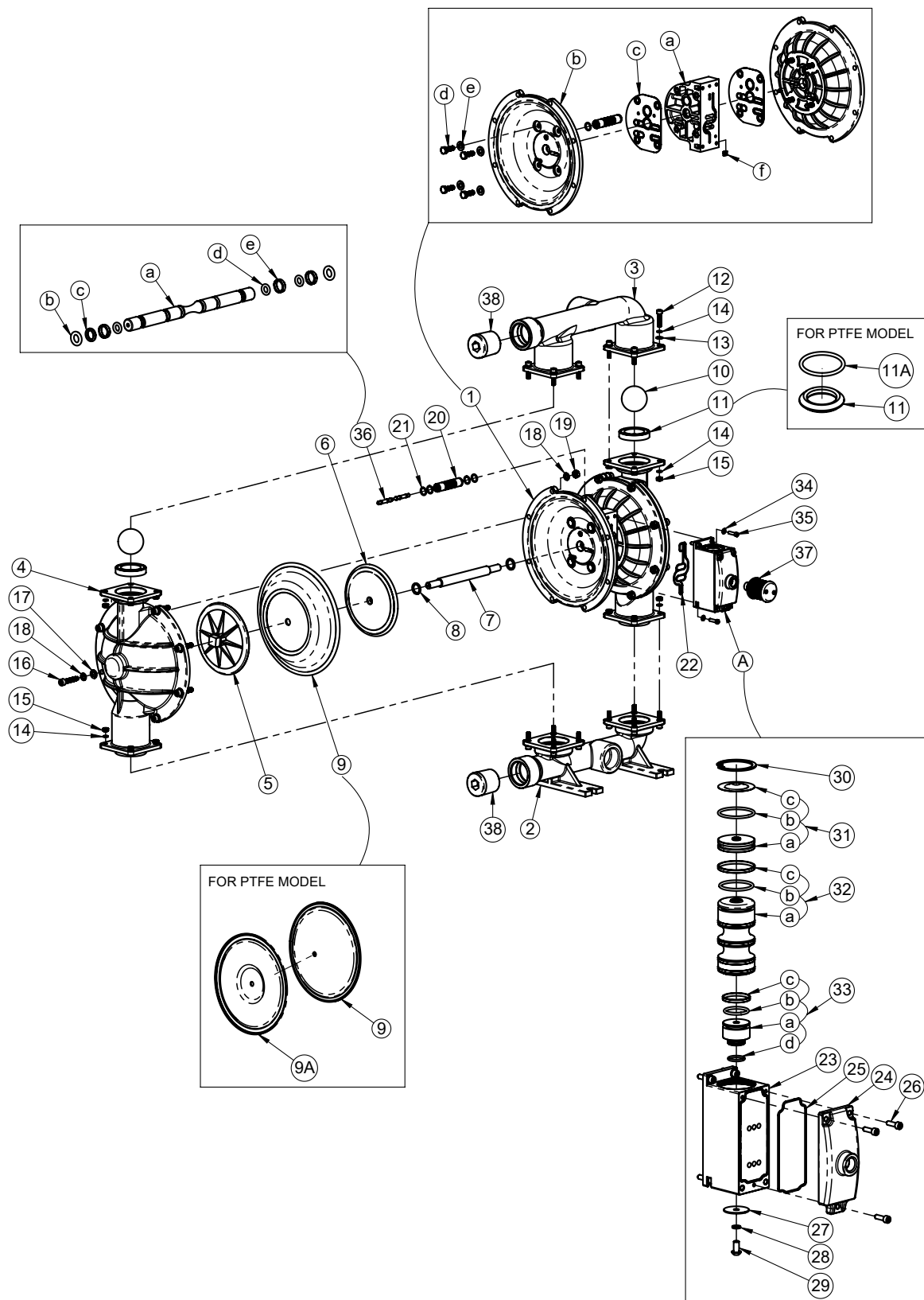

Bill of Materials for TP50-SSX- Pumps

ITEM NO.	PART NUMBER	DESCRIPTION	REX	RCX
1	1850704	Shaft Housing Assembly-TP50	1	1
a	1850704-2	Centre Piece-TP40/50	1	1
b	1850704-1	Air Disc-TP50	2	2
c	2034001	Gasket-TP40/50	2	2
d	6372770S	Hex Bolt	8	8
e	2039003S	Plain Washer	8	8
f	2039011S	Square Nut	4	4
2	1850701	Inlet Base-TP50	1	-
2*	1850707	Inlet Base-TP50	-	1
3	1850702	Outlet-TP50	1	-
3*	1850708	Outlet-TP50	-	1
4	1850703	Outer Chamber-TP50	2	2
5	2020704	Outer Flange-TM50	2	2
6	2021002	Inner Flange-TM50/TP50	2	2
7	2032104	Primary Shaft-TP50	1	1
8	2004013	Square Ring	2	2
9	2024101	Diaphragm-TM50/TP50	2	2
10	2024103	Ball-TM50/TP50	4	4
11	2024102	Ball Seat-TM50/TP50	4	4
12	2589026S	Allen Bolt	16	16
13	1712749S	Plain Washer	16	16
14	1712720S	Spring Washer	32	32
15	3200127S	Hex Nut	16	16
16	1859001S	Allen Bolt	16	16
17	2039003S	Plain Washer	16	16
18	2129007S	Spring Washer	32	32
19	1759002S	Hex Nut	16	16
20	2032103	Sleeve-TP40/50	1	1
21	2034003	O Ring	4	4
22	2034004	Skeleton Seal-TP40/50	1	1

ITEM NO.	PART NUMBER	DESCRIPTION	REX	RCX
A	2039711S	Air Valve Assembly-TP40/50	1	1
23	1850705	Air Valve Body-TP40/50	1	1
24	1850706	Air Valve Body Cover-TP50	1	1
25	2034008	O Ring	1	1
26	1712719S	Allen Bolt	3	3
27	2039015S	Plain Washer	1	1
28	5369014S	Spring Washer	1	1
29	1679004	Button Head Screw-TP15/25	1	1
30	2039009	Internal Circlip	1	1
31	2030803	End Cap Set-TP40/50	1	1
a	2030803-1	End Cap-TP40/50	1	1
b	2034005	O Ring	1	1
c	2038201	End Cap Cover	1	1
32	2039801	Air Piston Assembly-TP40/50	1	1
a	2030801	Air Piston-TP40/50	1	1
b	2034007	O Ring	5	5
c	2033601	Seal	5	5
33	2039803	Differential Cap Assembly-TP40/50	1	1
a	2030802	Differential Cap-TP40/50	1	1
b	2034006	O Ring	1	1
c	2033603	Seal	1	1
d	1634001	O Ring	1	1
34	6129011S	Plain Washer	4	4
35	2039010S	Allen Bolt	4	4
36	2039804	Secondary Shaft Assembly-TP40/50	1	1
a	2032106	Secondary Shaft-TP50	1	1
b	0229030	O Ring	2	2
c	2033605	Seal	1	1
d	2034010	O Ring	3	3
e	2033604	Seal	3	3
37	8059801	Silencer	1	1
38	1852301	Plug	-	2

Note.

Above all parts are common for End port & Centre port (NPT) models only. For BSPT/ BSPP model refer below part no.s. (* marked refer for Centre Port models)

ITEM NO.	PART NUMBER	DESCRIPTION	BSPT	BSPP
1a	1850704-2G	Centre Piece-TP40/50	1	-
1a	1850704-2P	Centre Piece-TP40/50	-	1
2	1850701G	Inlet Base-TP50	1	-
2	1850701P	Inlet Base-TP50	-	1
2*	1850707G	Inlet Base-TP50	1	-
2*	1850707P	Inlet Base-TP50	-	1
3	1850702G	Outlet-TP50	1	-
3	1850702P	Outlet-TP50	-	1
3*	1850708G	Outlet-TP50	1	-
3*	1850708P	Outlet-TP50	-	1

Bill of Materials for TP50-SBX- Pumps

ITEM NO.	PART NUMBER	DESCRIPTION	REX	RCX
1	1850704	Shaft Housing Assembly-TP50	1	1
a	1850704-2	Centre Piece-TP40/50	1	1
b	1850704-1	Air Disc-TP50	2	2
c	2034001	Gasket-TP40/50	2	2
d	6372770S	Hex Bolt	8	8
e	2039003S	Plain Washer	8	8
f	2039011S	Square Nut	4	4
2	1850701	Inlet Base-TP50	1	-
2*	1850707	Inlet Base-TP50	-	1
3	1850702	Outlet-TP50	1	-
3*	1850708	Outlet-TP50	-	1
4	1850703	Outer Chamber-TP50	2	2
5	2020704	Outer Flange-TM50	2	2
6	2021002	Inner Flange-TM50/TP50	2	2
7	2032104	Primary Shaft-TP50	1	1
8	2004013	Square Ring	2	2
9	2024041B	Diaphragm-TM50/TP50	2	2
10	2004043B	Ball-TM50/TP50	4	4
11	2004045B	Ball Seat-TM50/TP50	4	4
12	2589026S	Allen Bolt	16	16
13	1712749S	Plain Washer	16	16
14	1712720S	Spring Washer	32	32
15	3200127S	Hex Nut	16	16
16	1859001S	Allen Bolt	16	16
17	2039003S	Plain Washer	16	16
18	2129007S	Spring Washer	32	32
19	1759002S	Hex Nut	16	16
20	2032103	Sleeve-TP40/50	1	1
21	2034003	O Ring	4	4
22	2034004	Skeleton Seal-TP40/50	1	1

ITEM NO.	PART NUMBER	DESCRIPTION	REX	RCX
A	2039711S	Air Valve Assembly-TP40/50	1	1
23	1850705	Air Valve Body-TP40/50	1	1
24	1850706	Air Valve Body Cover-TP50	1	1
25	2034008	O Ring	1	1
26	1712719S	Allen Bolt	3	3
27	2039015S	Plain Washer	1	1
28	5369014S	Spring Washer	1	1
29	1679004	Button Head Screw-TP15/25	1	1
30	2039009	Internal Circlip	1	1
31	2030803	End Cap Set-TP40/50	1	1
a	2030803-1	End Cap-TP40/50	1	1
b	2034005	O Ring	1	1
c	2038201	End Cap Cover	1	1
32	2039801	Air Piston Assembly-TP40/50	1	1
a	2030801	Air Piston-TP40/50	1	1
b	2034007	O Ring	5	5
c	2033601	Seal	5	5
33	2039803	Differential Cap Assembly-TP40/50	1	1
a	2030802	Differential Cap-TP40/50	1	1
b	2034006	O Ring	1	1
c	2033603	Seal	1	1
d	1634001	O Ring	1	1
34	6129011S	Plain Washer	4	4
35	2039010S	Allen Bolt	4	4
36	2039804	Secondary Shaft Assembly-TP40/50	1	1
a	2032106	Secondary Shaft-TP50	1	1
b	0229030	O Ring	2	2
c	2033605	Seal	1	1
d	2034010	O Ring	3	3
e	2033604	Seal	3	3
37	8059801	Silencer	1	1
38	1852301	Plug	-	2

Note.

Above all parts are common for End port & Centre port (NPT) models only. For BSPT/ BSPP model refer below part no.s. (* marked refer for Centre Port models)

ITEM. NO.	PART NUMBER	DESCRIPTION	BSPT	BSPP
1a	1850704-2G	Centre Piece-TP40/50	1	-
1a	1850704-2P	Centre Piece-TP40/50	-	1
2	1850701G	Inlet Base-TP50	1	-
2	1850701P	Inlet Base-TP50	-	1
2*	1850707G	Inlet Base-TP50	1	-
2*	1850707P	Inlet Base-TP50	-	1
3	1850702G	Outlet-TP50	1	-
3	1850702P	Outlet-TP50	-	1
3*	1850708G	Outlet-TP50	1	-
3*	1850708P	Outlet-TP50	-	1

Bill of Materials for TP50-STS- Pumps

ITEM NO.	PART NUMBER	DESCRIPTION	REX	RCX
1	1850704	Shaft Housing Assembly-TP50	1	1
a	1850704-2	Centre Piece-TP40/50	1	1
b	1850704-1	Air Disc-TP50	2	2
c	2034001	Gasket-TP40/50	2	2
d	6372770S	Hex Bolt	8	8
e	2039003S	Plain Washer	8	8
f	2039011S	Square Nut	4	4
2	1850701	Inlet Base-TP50	1	-
2*	1850707	Inlet Base-TP50	-	1
3	1850702	Outlet-TP50	1	-
3*	1850708	Outlet-TP50	-	1
4	1850703	Outer Chamber-TP50	2	2
5	2020704	Outer Flange-TM50	2	2
6	2021002	Inner Flange-TM50/TP50	2	2
7	2032104	Primary Shaft-TP50	1	1
8	2004013	Square Ring	2	2
9	1854101	Backup Diaphragm (Full Stroke)-TP50	2	2
9A	1853601T	Diaphragm (Full Stroke)-TP50	2	2
10	2003643T	Ball-TM50/TP50	4	4
11	2022701	Ball Seat-TM50/TP50	4	4
11A	2023601T	O Ring	4	4
12	2589026S	Allen Bolt	16	16
13	1712749S	Plain Washer	16	16
14	1712720S	Spring Washer	32	32
15	3200127S	Hex Nut	16	16
16	1859001S	Allen Bolt	16	16
17	2039003S	Plain Washer	16	16
18	2129007S	Spring Washer	32	32
19	1759002S	Hex Nut	16	16
20	2032103	Sleeve-TP40/50	1	1
21	2034003	O Ring	4	4
22	2034004	Skeleton Seal-TP40/50	1	1

ITEM NO.	PART NUMBER	DESCRIPTION	REX	RCX
A	2039711S	Air Valve Assembly-TP40/50	1	1
23	1850705	Air Valve Body-TP40/50	1	1
24	1850706	Air Valve Body Cover-TP50	1	1
25	2034008	O Ring	1	1
26	1712719S	Allen Bolt	3	3
27	2039015S	Plain Washer	1	1
28	5369014S	Spring Washer	1	1
29	1679004	Button Head Screw-TP15/25	1	1
30	2039009	Internal Circlip	1	1
31	2030803	End Cap Set-TP40/50	1	1
a	2030803-1	End Cap-TP40/50	1	1
b	2034005	O Ring	1	1
c	2038201	End Cap Cover	1	1
32	2039801	Air Piston Assembly-TP40/50	1	1
a	2030801	Air Piston-TP40/50	1	1
b	2034007	O Ring	5	5
c	2033601	Seal	5	5
33	2039803	Differential Cap Assembly-TP40/50	1	1
a	2030802	Differential Cap-TP40/50	1	1
b	2034006	O Ring	1	1
c	2033603	Seal	1	1
d	1634001	O Ring	1	1
34	6129011S	Plain Washer	4	4
35	2039010S	Allen Bolt	4	4
36	2039804	Secondary Shaft Assembly-TP40/50	1	1
a	2032106	Secondary Shaft-TP50	1	1
b	0229030	O Ring	2	2
c	2033605	Seal	1	1
d	2034010	O Ring	3	3
e	2033604	Seal	3	3
37	8059801	Silencer	1	1

Note.

Above all parts are common for End port & Centre port (NPT) models only. For BSPT/ BSPP model refer below part no.s. (* marked refer for Centre Port models)

ITEM. NO.	PART NUMBER	DESCRIPTION	BSPT	BSPP
1a	1850704-2G	Centre Piece-TP40/50	1	-
1a	1850704-2P	Centre Piece-TP40/50	-	1
2	1850701G	Inlet Base-TP50	1	-
2	1850701P	Inlet Base-TP50	-	1
2*	1850707G	Inlet Base-TP50	1	-
2*	1850707P	Inlet Base-TP50	-	1
3	1850702G	Outlet-TP50	1	-
3	1850702P	Outlet-TP50	-	1
3*	1850708G	Outlet-TP50	1	-
3*	1850708P	Outlet-TP50	-	1

Bill of Materials for TP50-STB- Pumps

ITEM NO.	PART NUMBER	DESCRIPTION	REX	RCX
1	1850704	Shaft Housing Assembly-TP50	1	1
a	1850704-2	Centre Piece-TP40/50	1	1
b	1850704-1	Air Disc-TP50	2	2
c	2034001	Gasket-TP40/50	2	2
d	63727705	Hex Bolt	8	8
e	2039003S	Plain Washer	8	8
f	2039011S	Square Nut	4	4
2	1850701	Inlet Base-TP50	1	-
2*	1850707	Inlet Base-TP50	-	1
3	1850702	Outlet-TP50	1	-
3*	1850708	Outlet-TP50	-	1
4	1850703	Outer Chamber-TP50	2	2
5	2000725S	Outer Flange-TM50	2	2
5A	2002736S	Hex Bolt	2	2
6	2001027	Inner Flange-TM50/TP50	2	2
7	2032105	Primary Shaft-TP50	1	1
8	2004013	Square Ring	2	2
9	2004066B	Backup Diaphragm-TP50	2	2
9A	2003641T	Diaphragm-TP50	2	2
10	2003643T	Ball-TM50/TP50	4	4
11	2022701	Ball Seat-TM50/TP50	4	4
11A	2023601T	O Ring	4	4
12	2589026S	Allen Bolt	16	16
13	1712749S	Plain Washer	16	16
14	1712720S	Spring Washer	32	32
15	3200127S	Hex Nut	16	16
16	1859001S	Allen Bolt	16	16
17	2039003S	Plain Washer	16	16
18	2129007S	Spring Washer	32	32
19	1759002S	Hex Nut	16	16
20	2032103	Sleeve-TP40/50	1	1
21	2034003	O Ring	4	4
22	2034004	Skeleton Seal-TP40/50	1	1

ITEM NO.	PART NUMBER	DESCRIPTION	REX	RCX
A	2039711S	Air Valve Assembly-TP40/50	1	1
23	1850705	Air Valve Body-TP40/50	1	1
24	1850706	Air Valve Body Cover-TP50	1	1
25	2034008	O Ring	1	1
26	1712719S	Allen Bolt	3	3
27	2039015S	Plain Washer	1	1
28	5369014S	Spring Washer	1	1
29	1679004	Button Head Screw-TP15/25	1	1
30	2039009	Internal Circlip	1	1
31	2030803	End Cap Set-TP40/50	1	1
a	2030803-1	End Cap-TP40/50	1	1
b	2034005	O Ring	1	1
c	2038201	End Cap Cover	1	1
32	2039801	Air Piston Assembly-TP40/50	1	1
a	2030801	Air Piston-TP40/50	1	1
b	2034007	O Ring	5	5
c	2033601	Seal	5	5
33	2039803	Differential Cap Assembly-TP40/50	1	1
a	2030802	Differential Cap-TP40/50	1	1
b	2034006	O Ring	1	1
c	2033603	Seal	1	1
d	1634001	O Ring	1	1
34	6129011S	Plain Washer	4	4
35	2039010S	Allen Bolt	4	4
36	2039804	Secondary Shaft Assembly-TP40/50	1	1
a	2032106	Secondary Shaft-TP50	1	1
b	0229030	O Ring	2	2
c	2033605	Seal	1	1
d	2034010	O Ring	3	3
e	2033604	Seal	3	3
37	8059801	Silencer	1	1

Note.

Above all parts are common for End port & Centre port (NPT) models only. For BSPT/ BSPP model refer below part no.s. (* marked refer for Centre Port models)

ITEM. NO.	PART NUMBER	DESCRIPTION	BSPT	BSPP
1a	1850704-2G	Centre Piece-TP40/50	1	-
1a	1850704-2P	Centre Piece-TP40/50	-	1
2	1850701G	Inlet Base-TP50	1	-
2	1850701P	Inlet Base-TP50	-	1
2*	1850707G	Inlet Base-TP50	1	-
2*	1850707P	Inlet Base-TP50	-	1
3	1850702G	Outlet-TP50	1	-
3	1850702P	Outlet-TP50	-	1
3*	1850708G	Outlet-TP50	1	-
3*	1850708P	Outlet-TP50	-	1

Replacement & Repair Kits for TP50 SSX Pump

ITEM NO.	PART NUMBER	DESCRIPTION	Replacement Kit 2039701S	Repair Kit 1859701-S	Repair Kit 1859701-B	Repair Kit 1859701-T	Repair Kit 1859701-TB
8	2004013	Square Ring	-	2	2	2	2
9	2024101	Diaphragm-TM50/TP50	-	2	-	-	-
9	2024041B	Diaphragm-TM50/TP50	-	-	2	-	-
9	1854101	Backup Diaphragm (Full Stroke)-TP50	-	-	-	2	-
9	2004066B	Backup Diaphragm-TM50	-	-	-	-	2
9A	1853601T	Diaphragm (Full Stroke)-TP50	-	-	-	2	-
9A	2003641T	Diaphragm-TM50	-	-	-	-	2
10	2024103	Ball-TM50/TP50	-	4	-	-	-
10	2004043B	Ball-TM50/TP50	-	-	4	-	-
10	2003643T	Ball-TM50	-	-	-	4	4
11	2024102	Ball Seat-TM50/TP50	-	4	-	-	-
11A	2023601T	O Ring	-	-	-	4	4
22	2034004	Skeleton Seal-TP40/50	1	1	1	1	1
23	1850705	Air Valve Body-TP40/50	1	-	-	-	-
24	1850706	Air Valve Body Cover-TP50	1	-	-	-	-
25	2034008	O Ring	1	1	1	1	1
26	1712719S	Allen Bolt	3	-	-	-	-
27	2039015S	Plain Washer	1	1	1	1	1
28	5369014S	Spring Washer	1	1	1	1	1
29	1679004	Button Head Screw-TP15/25	1	1	1	1	1
30	2039009	Internal Circlip	1	1	1	1	1
31	2030803	End Cap Set-TP40/50	1	1	1	1	1
32	2039801	Air Piston Assembly-TP40/50	1	1	1	1	1
33	2039803	Differential Cap Assembly-TP40/50	1	1	1	1	1
34	6129011S	Plain Washer	4	-	-	-	-
35	2039010S	Allen Bolt	4	-	-	-	-
36	2039804	Secondary Shaft Assembly-TP50	-	1	1	1	1

Dimensional Data

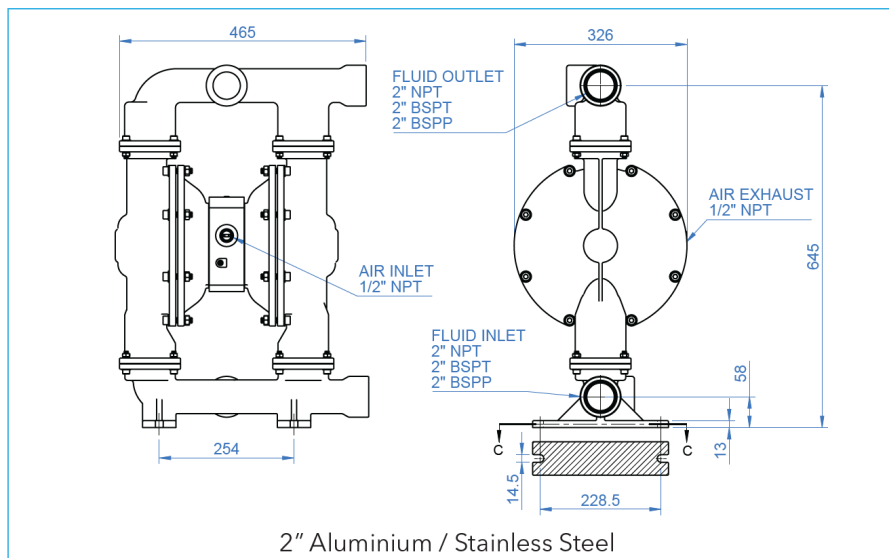

EU DECLARATION OF CONFORMITY**Object of declaration**

PRODUCT : **AIR OPERATED DOUBLE DIAPHRAGM PUMP**

MODEL : **TP50 Series**

MANUFACTURER'S NAME : **TERYAIR EQUIPMENT PVT. LTD.**

ADDRESS : **SITE - 1 : BUILDING A - 1/2, 102 TO 105 & BUILDING C 12 & 13,
TIRUPATI UDYOG NAGAR, SATIVALI ROAD, VASAI (E),
PALGHAR: 401208.
SITE - 2: AUGUSTINE - II, COLACO INDUSTRIAL COMPLEX,
GALA NO - 101 TO 107, SATIVALI ROAD, VILLAGE WALIV,
VASAI (E), PALGHAR: 401208**

To provide presumption of conformity in order to directive 2014/34/EU; the following harmonized standards and/or other normative documents as referenced within the following official journals are applied:

APPLICABLE DIRECTIVE: ATEX DIRECTIVE (2014/34/EU)

APPLICABLE STANDARDS:

EN ISO 80079-36: 2016 : Explosive atmospheres —Part 36: Non-electrical equipment for explosive atmospheres —Basic method and requirements.

EN ISO 80079-37:2016 : Explosive atmospheres —Part 37: Non-electrical equipment for explosive atmospheres —Non- electrical type of protection constructional safety 'c', control of ignition sources 'b', liquid immersion 'k'.

Notified body to whom Technical file has logged with: - Technicka Inspekcia (Ref: 1354).

DECLARATION: - TERYAIR EQUIPMENT PVT. LTD., declare that under our sole responsibility for the supply of the product defined above, the said product complies with all the applicable Directives, Regulations and all essential Health and Safety requirements applying to it.

I, the undersigned, hereby declare that the product specified above conforms to the above standard(s).

ATEX MARKING APPLIED



Please Refer ATEX Rating for **Teryair Aodd Models Table**

Signed for and on behalf of

TERYAIR EQUIPMENT PVT. LTD.

Place of Issue : Vasai

SUMMARY FOR THE ATEX RATING FOR TERYAIR AODD MODELS

Pump Size	Series	Wetted Materials	Center Section	Diphargm Materials	ATEX Rating
06 (1/4")	SDP	Aluminium	Aluminium	Neoprene	II 2 GD Ex h IIC T6 Gb Ex h IIIC T85°C Db (IP65)
				Buna-N	
				Viton-FKM	II 2 GD Ex h IIC T3 Gb Ex h IIIC T200°C Db (IP65)
				Sentoprene	II 2 GD Ex h IIC T5 Gb Ex h IIIC T100°C Db (IP65)
				Hytrel	
		PTFE			
		Stainless Steel	Stainless Steel	Neoprene	II 2 GD Ex h IIC T6 Gb Ex h IIIC T85°C Db I M2 Ex h I Mb (IP65)
				Buna-N	
				Viton-FKM	II 2 GD Ex h IIC T3 Gb Ex h IIIC T200°C Db (IP65) I M2 Ex h I Mb (IP65)
				Sentoprene	II 2 GD Ex h IIC T5 Gb Ex h IIIC T100°C Db (IP65) I M2 Ex h I Mb (IP65)
Hytrel					
PTFE					
12 (1/2")	DP/SDP	Aluminium	Aluminium	Neoprene	II 2 GD Ex h IIC T6 Gb Ex h IIIC T85°C Db (IP65)
				Buna-N	
				Viton-FKM	II 2 GD Ex h IIC T3 Gb Ex h IIIC T200°C Db (IP65)
				Sentoprene	II 2 GD Ex h IIC T5 Gb Ex h IIIC T100°C Db (IP65)
				Hytrel	
	PTFE				
	SDP	Stainless Steel	Stainless Steel	Neoprene	II 2 GD Ex h IIC T6 Gb Ex h IIIC T85°C Db I M2 Ex h I Mb (IP65)
				Buna-N	
				Viton-FKM	II 2 GD Ex h IIC T3 Gb Ex h IIIC T200°C Db (IP65) I M2 Ex h I Mb (IP65)
				Sentoprene	II 2 GD Ex h IIC T5 Gb Ex h IIIC T100°C Db (IP65) I M2 Ex h I Mb (IP65)
Hytrel					
PTFE					
25 (1")	DP / SDP	Aluminium / Stainless Steel	Aluminium	Neoprene	II 2 GD Ex h IIC T6 Gb Ex h IIIC T85°C Db (IP65)
				Buna-N	
				Viton-FKM	II 2 GD Ex h IIC T3 Gb Ex h IIIC T200°C Db (IP65)
				Sentoprene	II 2 GD Ex h IIC T5 Gb Ex h IIIC T100°C Db (IP65)
				Hytrel	
				PTFE	

SUMMARY FOR THE ATEX RATING FOR TERYAIR AODD MODELS

Pump Size	Series	Wetted Materials	Center Section	Diphragm Materials	ATEX Rating
40 (1-1/2")	DP / SDP	Aluminium / Stain- less Steel	Aluminium	Neoprene	II 2 GD Ex h IIC T6 Gb Ex h IIIC T85°C Db (IP65)
				Buna-N	
				Viton-FKM	II 2 GD Ex h IIC T3 Gb Ex h IIIC T200°C Db (IP65)
				Sentoprene	II 2 GD Ex h IIC T5 Gb Ex h IIIC T100°C Db (IP65)
				Hytrel	
				PTFE	
50 (2")	DP / SDP	Aluminium / Stain- less Steel	Aluminium	Neoprene	II 2 GD Ex h IIC T6 Gb Ex h IIIC T85°C Db (IP65)
				Buna-N	
				Viton-FKM	II 2 GD Ex h IIC T3 Gb Ex h IIIC T200°C Db (IP65)
				Sentoprene	II 2 GD Ex h IIC T5 Gb Ex h IIIC T100°C Db (IP65)
				Hytrel	
				PTFE	
	SDP	Cast Iron	Cast Iron	Neoprene	II 2 GD Ex h IIC T6 Gb Ex h IIIC T85°C Db I M2 Ex h I Mb (IP65)
				Buna-N	
				Viton-FKM	"II 2 GD Ex h IIC T3 Gb Ex h IIIC T200°C Db (IP65) I M2 Ex h I Mb (IP65)"
				Sentoprene	II 2 GD Ex h IIC T5 Gb Ex h IIIC T100°C Db (IP65) I M2 Ex h I Mb (IP65)
				Hytrel	
				PTFE	
75 (3")	DP / SDP	Aluminium	Aluminium	Neoprene	II 2 GD Ex h IIC T6 Gb Ex h IIIC T85°C Db (IP65)
				Buna-N	
				Viton-FKM	II 2 GD Ex h IIC T3 Gb Ex h IIIC T200°C Db (IP65)
				Sentoprene	II 2 GD Ex h IIC T5 Gb Ex h IIIC T100°C Db (IP65)
				Hytrel	
				PTFE	
	SDP	Cast Iron	Cast Iron	Neoprene	II 2 GD Ex h IIC T6 Gb Ex h IIIC T85°C Db I M2 Ex h I Mb (IP65)
				Buna-N	
				Viton-FKM	II 2 GD Ex h IIC T3 Gb Ex h IIIC T200°C Db (IP65) I M2 Ex h I Mb (IP65)
				Sentoprene	II 2 GD Ex h IIC T5 Gb Ex h IIIC T100°C Db (IP65) I M2 Ex h I Mb (IP65)
				Hytrel	
				PTFE	



Warranty Certificate

Every product manufactured by Teryair
is built to meet the highest standards of quality.

Teryair warrants that the Products, accessories and parts manufactured or supplied by the company be free from defects in material and workmanship for a period of six months from date of Teryair authorized dealer invoice to customer, or one year from date of Teryair invoice to dealer, whichever is earlier. Failure due to normal wear, misapplication, or abuse is, of course, excluded from this warranty.

Since the use of Teryair products and parts is beyond our control, Teryair cannot guarantee the suitability of any product or part for a particular application and Teryair shall not be liable for any consequential damage or expense arising from the use or misuse of its products on any application. Teryair does not warranty bought out products or components such as electric motors and hardware but will assist in directing warranty queries to the dealer/manufacturer responsible. Teryair responsibility is limited solely to replacement or repair of defective Teryair products or components.

Dealer/End User shall have no right or remedy and Teryair shall have no liability or obligation under the warranty, if: (i) a Product is altered, changed, modified or tampered with in any way; (ii) a Product is damaged after deposit with the transporter for shipment; (iii) a Product is not properly preserved, packaged, stored, processed or handled after receipt; (iv) a Product is not used and maintained in accordance with Teryair's recommended operating and maintenance manuals, instructions and procedures, if any; (v) a Product is not properly incorporated or installed in, or not properly combined with, an Other Product; (vi) the issue with a Product is directly or indirectly attributable to, or directly or indirectly results from or arises out of, a failure, substandard performance or other issue with another product, material, component or part not supplied by Teryair; (vii) the issue with a Product is directly or indirectly attributable to, or directly or indirectly results from or arises out of, compliance with any design, specification or other specific requirement of Dealer/End User; (viii) a Product is used in a manner, with a substance or for a purpose other than the normal manner, substance and purpose for which it is intended or is otherwise subjected to abnormal use or service; (ix) a Product is subjected to a power surge, brown out or other similar occurrence; (x) the issue with a Product is directly or indirectly attributable to, or directly or indirectly results from or arises out of, normal wear and tear of such Product (including, without limitation, things such as worn seals, diaphragms, balls, O rings, gaskets, chisels, cutters, hoses and other such wearing components; (xi) the issue with a Product is directly or indirectly.

A handwritten signature in blue ink, appearing to read "M. Yadav", is written over a horizontal line.

M Yadav, Q.A. Manager

(Company Seal)

This page is intentionally
Left blank.