

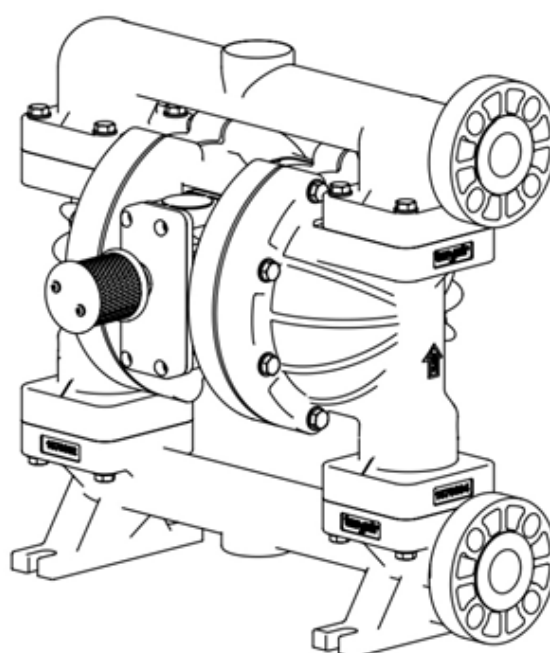

Operation and Maintenance Guide



TC25 Plastic Pump Series

Models	Descriptions
TC25-PSX-FEX-XXX	Teryair 1" Diaphragm Pump TeryChem Polypropylene Santoprene Flange End Port
TC25-PTS-FEX-XXX	Teryair 1" Diaphragm Pump TeryChem Polypropylene PTFE-Santoprene Flange End Port

Read this manual carefully before installing, operating or servicing this equipment. It's the responsibility of the employer to ensure this manual is read by the operator. Please preserve this manual.

Table of Contents

3	Pump Nomenclature
3	Operating and Safety instructions
4	Operating Instructions
5	Caution: Temperature limitations and diaphragm options
5	Suggested Lubricants
6	Suggested site selection and installation recommendations
7	Troubleshooting
8	Maintenance
8	Diassembly and Re-assembly
10	Re-assembly
10	Maximum Torque Specifications (TC 25 Series)
11	Exploded View for TC25 Pump
12	Bill of Materials for TC25-PSX-FEX-XXX
13	Bill of Materials for TC25-PTS-FEX-XXX
14	Replacement & Repair Kits for TC25 Series Pump
14	Dimensional Data
15	Eu Declaration Of Conformity
16	Warranty Certificate

Pump Nomenclature

Position	1	2	3	4	5	6	7	8	9	10	11
Example	TC	15	P	T	I	G	E	X	X	X	X

Example: TC15-PTI-GEX-XXX

Position 1 Range	Position 2 Size	Position 3 Body	Position 4 Diaphragm/ Valve	Position 5 Back Up	Position 6 Port	Position 7 Port Position	Position 8 Speciality Code	Position 9 Safety Code	Position 10 Sanitary Code	Position 11 Speciality Code
TC-Chemical	15 - 1/2" 25 - 1" 40 - 1-1/2" 50 - 2"	P - Polypropylene	S - Santoprene O - One Piece PTFE T - PTFE	S - Santoprene X - None	G - BSPT F - Flanged ANSI/DIN R - NPT P - BSPP See Foot Note 2	C - Centre Ported Vertical, End Port Plugged, See Foot Note 1 E - End Ported	P - Pulse Dampener R - Remote Solenoid Driven T - Trolley Mounted X - None	X - None	X - None	S - Speed Controller C - Cycle Counter D - Diaphragm Monitoring X - None

Foot note 1 - This option available only in 1/2"

Foot note 2 - F - indicates Default Flange Pump, R Indicates Defaults Flange with NPT Thread on Companion Flange, G Indicates Defaults Flange with BSPT Thread on Companion Flange, P Indicates Defaults Flange with BSPP Thread on Companion Flange,

Operating and Safety Instructions

⚠ Warning: Static Electricity

- Static sparks can cause explosion resulting in severe injury or death.
- Ground the pump and the pump connections like hoses and containers into which or from the fluid is being transferred. Connect the grounding wire to any bolt on the pump.
- Check continuity of electrical path to ground at regular intervals.
- Consult local building and electrical codes for grounding requirements where needed.
- Use hoses containing a grounding wire.

⚠ Warning: Pump Exhaust

In case of a diaphragm failure, fluid being pumped may spray out from the exhaust of the pump. This may cause severe injury depending on the fluid being pumped.

If the fluid is hazardous, pipe away the exhaust to a safe remote location using a generous diameter pipe preferably with a grounding arrangement, and refit the muffler at the end of this arrangement.

Always wear safety glasses while in the vicinity of an operating pump.

⚠ Warning: Over pressure / Hazardous Pressure

Do not exceed the max supply air pressure of 100 PSI.
Make sure all connected hoses and pipelines are rated to operate safely with the pressures generated by pump of 100 PSI.
Do not open or handle pump or hoses while pressurized.
Disconnect air supply line and relieve pressure from the system by carefully opening discharge and supply lines.

⚠ Warning: Hazardous Materials

Do not move a pump that contains hazardous fluids trapped inside it. Please observe prescribed handling and safety codes. Drain the pump safely, by turning it upside down and collecting the fluid safely, before moving the pump.

⚠ Warning: Explosion

Please check compatibility of fluids intended to be handled with the materials of construction of the pump. Severe reactions and explosions may occur if materials are incompatible.

 **Caution: Chemical compatibility**

Please check that the fluid being pumped is compatible with the wetted parts of the pump. Re-fer Cole Parmer compatibility (<http://www.coleparmer.in/Chemical-Resistance>) guide for de-tails. Note that chemical compatibility may change with temperature; take this into account while selecting pump material.

 **Caution: Structural support**

Please refer figure 1 and ensure that the piping system is independently supported and does not load the pump. The pumps are not designed to take the continuous and often pulsating load of a piping system. Important to use a flexible connection between rigid piping and pump casings.

 **Caution: Running dry, disconnection of hoses when not in use**

Although these pumps can be run dry for long periods, it is advisable to avoid this as it causes unnecessary wear of wearing parts

 **Caution: Operator understanding**

Please ensure that all operators have read this manual and have the required understanding of safe working practices and are equipped with safety equipment when working on/around the pump.



 **Caution: Using genuine teryair fittings & spares**

Use genuine teryair parts to ensure correct pump operation and maximize life.

Operating Instructions

- The Teryair diaphragm pump generates a alternate stroking of the diaphragms against the fluid in the liquid chambers of the Pump. This reciprocatory action is responsible for the fluid being pumped.
- It is possible to control the output of the pump by controlling the supply air pressure.
- It is also possible to control the output of the pump by throttling action on the fluid flowing in the outlet piping by means of a valve. if such a valve is shut completely the pressure in the discharge piping increases to a point when the pressure at pump discharge equals it and the pump comes to a stop. This causes no damage to the pump and the pump consumes no more energy.
- Upon opening of the valve, the pump starts reciprocating once again and resumes fluid delivery.

 **Caution: Temperature limitations and diaphragm options**

Santoprene		Good abrasion resistance. Low cost. Can handle mild acids and alkalis well. Excellent low cost alternative to ptfе. Excellent suction capabilities Excellent general purpose diaphragm. Temperature range -40°C to +107°C (-40F to +225°F)
PTFE		Excellent choice when pumping highly aggressive fluids such as aromatic or chlorinated hydrocarbons, acids, caustics, ketones and acetates. Temperature range +4°C to +104°C (+40°F to +220°F)

Suggested Lubricants

Brand	Above 27 Deg C (From 5 Deg C to 27 Deg C	Below 5 Deg C
Shell	Toona R 72	Toona R 41	Toona R 27
Mobil	Almo 529	Almo 527	Almo 525
Esso	- - - -	Arox EP 65	Arox EP 45
Caltex	Rando Oil 150	Rando Oil 100	Rando Oil 46
Texaco	Regal Oil F	Regal Oil PE	Regal Oil B
Daltron	Silkolene 881	Silkolene 548	Silkolene 773
Burmah Castrol	RD Oil 3	RD Oil Light	Megna SPX
BP	RD 220 HP60C	RD150 HP20C	RD80 HP10C
Duckham	Garnet 7	Garnet 6	Zero Flo 5
Sternol	Merlin 87	Merlin 71	Merlin 54
Petrofina	Purifoc 53	Purifoc 46	Purifoc 32
Chevron	Vistac Oil 18X	Vistac Oil 19X	Vistac Oil 9X

Suggested site selection and installation recommendations

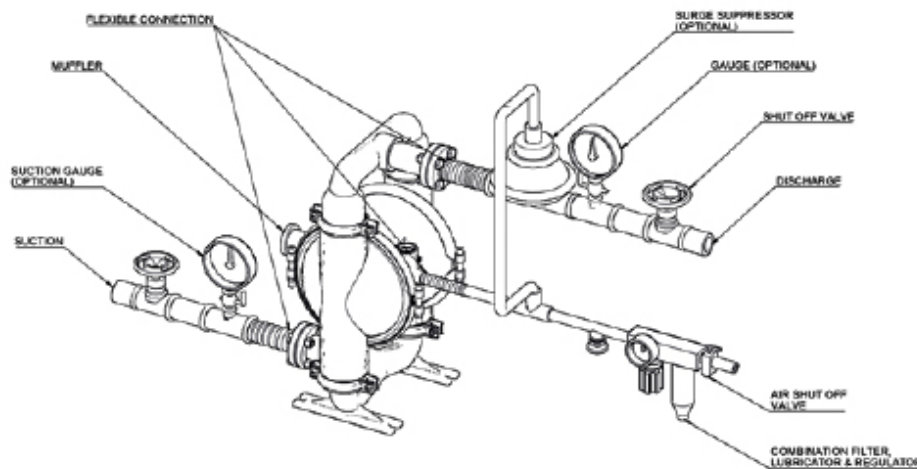

Figure 1

Location selection

Pump location must be easily accessible with reasonable space around for maintenance operations. Pump dimensional data for each variant is available in section showing exploded views

Air supply

Compressed air at 90 PSI (Stroke pumps can take a max of 100PSI), free from moisture and having an oil mist is essential. Use of a filter (50 microns), a lubricator and a regulator is highly recommended and should be installed as close as possible to the pump inlet.

Ensure correct grade of oil is used in the lubricator bowl. Too thick oil may slow down the valve shifting mechanism and affect pump performance. See suggested lubricants on page no 5.

Piping

A minimum number of bends and fittings to be used.

A flexible connection between suction, delivery and air supply piping is highly recommended such that piping stresses and loads do not transfer to pump housing. Select piping materials such that chemical compatibility is maintained with the fluid being pumped.

Suction

Ensure that the suction head after installation is well within the pumps suction capabilities

Muffler

Use of supplied muffler is recommended to bring pump operation sounds down to comfortable levels, in case of hazardous fluids handling, please read section of safety regarding piping away of exhaust see

Warning: Pump Exhaust) earlier in this manual.

Troubleshooting

Serial No	Description	Causes	Remedial Action
1	Pump stops and will not start	Insufficient Air Pressure	Check air pressure is as recommended at the pump air inlet
		Air Filter Blocked	Check if debris has clogged the inlet filter on the FRL unit/pump inlet air valve (some models have air filter on the air inlet valve) and ensure clear passage of air
		Internal damage or excessive wear on components	Proceed to dismantle the pump, examine component for wear, replace any worn components, re assemble carefully as instructed in this manual and re start the pump.
2	Pumps runs slowly, poor delivery	Cavitation	Check if cavitation is occurring in the suction side, if so reduce suction vacuum by slowing down the pump.
		Worn Balls and Seats	Check proper sealing action of balls against seals, these components need to be replaced as a set if they are worn.
		Insufficient or wrong lubricant in the air supply.	Ensure that the lubricant is as per the recommended chart, a thicker lubricant often makes the air valve work sluggishly
		Internal damage or excessive wear on components	Proceed to dismantle the pump, examine component for wear, replace any worn components, re assemble carefully as instructed in this manual and re start the pump.
3	Pump air valve freezes	Excessive moisture in supply air line.	Ensure that the dew point of the supplied air is low enough. Install a air dryer or moisture separator on the supply line
4	Air bubbles in pump discharge or product sprays out of exhaust vent	Broken Diaphragm	Proceed to dismantle the pump, examine component for wear, replace any worn components, re assembly carefully as instructed in this manual and re start the pump
		Improper seal between inner pistons, outer pistons and shaft.	
		Air leakage into product from balls / seats area	
		Air sucked into suction pipeline due to insufficiently tight joints on suction pipeline.	

Maintenance

Regular inspection and maintenance schedules will greatly enhance the life of the pump and will ensure a trouble free and safe working environment with little chance of breakdowns. Follow the instructions clearly in “Disassembly and Reassembly” of the pump and in the troubleshooting section.

Use genuine Teryair spares and if possible mention the serial number of the pump when ordering spares.

Always replace elastomers as a set, eg diaphragms, balls and seats.

Disassembly and Re-assembly

- Shut off air supply and allow residual Pressure to bleed off.
- Disconnect air supply
- Disconnect suction and discharge piping
- Turn pump upside down allow process fluid to drain away. If fluid is hazardous due care should be taken.
- Make a mark to indicate the positioning of each liquid chamber relative to the housing.
- NOTE: Replace worn parts with genuine Teryair parts for reliable performance.

1. Replacement of Ball seat & Ball

- Unscrew both bolt (18) & plain washer (20) as shown in the exploded view and proceed to remove the outlet (3) & inlet base (2) respectively.
- Now replace the ball (9), Oring (11 and 12) & ball seat (10).

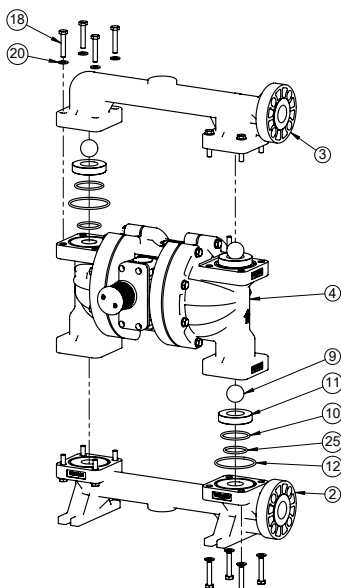

2. Replacement of Diaphragm

- Follow the step a & b for replacement of ball seat and ball.
- Now unscrew hex head bolt (17) & plane washer (20) of any one side and proceed to remove the outer chamber (4). Now repeat the same procedure.

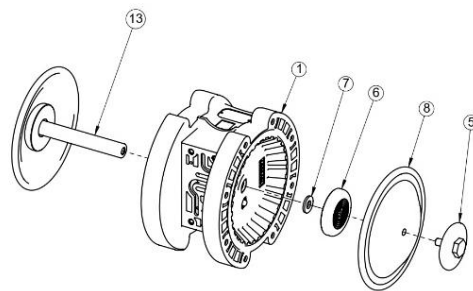

- Now with the help of two spanner hold one of the across flat of one outer flange (5) and rotate the second outer flange (5) to disassemble it from the shaft assembly. Remove the diaphragm (8), inner flange (6), spacer (7).
- Now pull out the half shaft assembly out of the shaft housing (1). Now hold the shaft (14) in a vice with proper packing. Care must be taken not to damage the shaft outer surface. Now remove the outer flange (5) with spanner.
- Now replace the diaphragms (8). Ensure that diaphragm orientation is correct. In case of PTFE, make sure PTFE side of diaphragm faces outer chamber (4). *In case of Santoprene, make sure the convex side Santoprene diaphragm faces outer chamber (4).

3. Replacement of Shaft Seals

- a) For removing the Seal (14) from Shaft Housing (1), first follow the steps a, b c & d from the diaphragm replacement.
- b) Now remove the seals (14) with the help of needle. Care should be taken not to damage the inner face of Shaft Housing.
- c) Once all the old seals are have been removed, the inside of the bore should be cleaned and ensure no debris is left that may damage to new seals (Pressurized air is preferable).
- e) The Blunt point Needle can be used to aid in the installation of new seals.
- f) Now place the Seal (14) nearby appropriate groove of Shaft Housing (1). Then push the seal into the groove with blunt point needle.
- g) Before the seal can be properly re-sized, the bump in the seal should be removed as much as possible. This can be done with your finger. Apply light pressure to the peak of the bump.
- h) Lubricate the edge of the shaft with specified lubricant. Then slowly insert the shaft with rotating motion to complete the re-sizing of the seals.
- i) Perform these steps for the remaining seals.

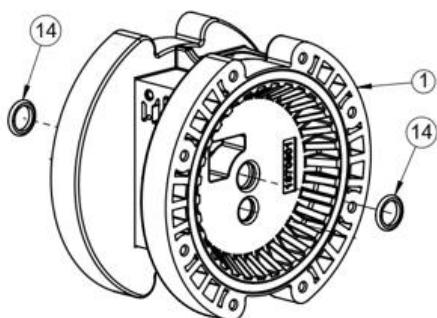

Air Valve/ Center Section Disassembly

4. Replacement Of Secondary Shaft Assembly

- a. For removing the secondary shaft assembly from shaft housing assembly. First follow the steps a, b, c, d from the diaphragm replacement and remove the outer chamber(4).
- b. Repeat the same procedure to remove the other side also.
- c. Now push the secondary shaft assembly (21) one side of shaft housing (1) and remove the end O rings (21e) from Secondary shaft assembly (21).
- d. Now if you see there is a center drill mark on one side of the secondary shaft assembly (21). Pull the secondary shaft assembly from that side only.
- e. During assembly make sure to push the secondary shaft assembly (21) from the plain side only into the sleeve (15).

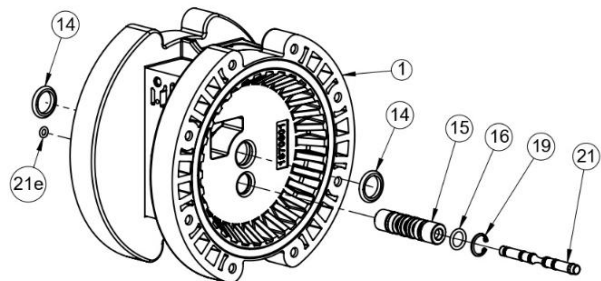

5. Replacement of Air Valve, Gasket, O-Rings of End Cap & Piston

O-Rings of End Cap & Piston

- a. Unscrew Allen bolts (22k) from shaft housing (1) and remove Air valve Assly (22) from housing (1). Now remove the Seal (22l) from Air valve Assly (22). While re-assembling replace Seal (22l) with new one.
- b. Remove the end cap (d) with it's Oring (22j) and now use a M6 Bolt to pull the Air piston (c) with its O-ring & Seals out of the air valve body (22a). This piston assembly needs to replace as a single piece.
- c. Also open cover (22b) from air valve body (22a) and replace O-ring (22i) with new one.

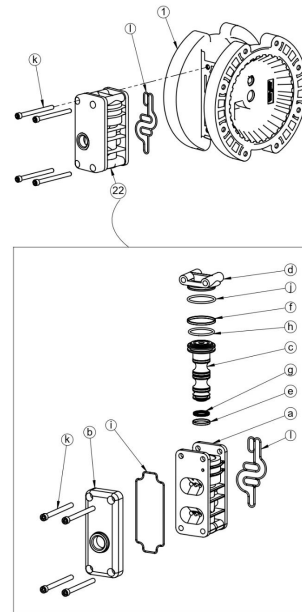

Re-Assembly

Upon performing applicable maintenance to the air distribution system, the pump can now be reassembled. Please refer to the dis-assembly instructions for photos and parts placement. To reassemble the pump, follow the dis-assembly instructions in reverse order. The air distribution system needs to be assembled first, then the Diaphragms and finally the wetted path. Please find the applicable torque specifications on this page. The following tips will assist in the assembly process.

- a. Clean the inside of the center section shaft bore to ensure no damage is done to new seals.
- b. Stainless bolts should be lubed to reduce the possibility of seizing during tightening.

- c. Level the water chamber side of the intake/discharge manifold to ensure a proper sealing surface. This is most easily accomplished by placing them on a flat surface prior to tightening their clamp bands to the desired torque (see below for Torque Specifications).
- d. Be sure to tighten outer pistons simultaneously on PTFE-fitted pumps to ensure proper torque values.
- e. Ensure proper mating of liquid chambers to manifolds prior to tightening vertical bolts. Overhang should be equal on both sides.
- f. Apply a small amount of Loctite 242 to the shaft interval threads before the diaphragm assembly.
- g. Concave side of disc spring in diaphragm assembly faces toward shaft.

Maximum Torque Specifications (TC 25 Series)

Description Of Part	Torque
Air Valve	5.1 N•m (45 in-lb)
Air Chamber/Center Block	47.5 N•m (35 ft-lb)
Outer Flanges, Rubber & PTFE, Excluding Stainless Steel Inner Pistons	106 N•m (78 ft-lb)
Outer Flanges, Rubber & PTFE, Stainless Steel Inner Pistons	119 N•m (88 ft-lb)
Outer Flanges, Ultra-Flex™	74.6 N•m (55 ft-lb)
Small Clamp Bands	6.6 N•m (58 in-lb)
Large Clamp Bands (Rubber-Fitted)	47.5 N•m (35 ft-lb)
Large Clamp Bands (PTFE-Fitted)	47.5 N•m (35 ft-lb)

Exploded View for TC25 Pump

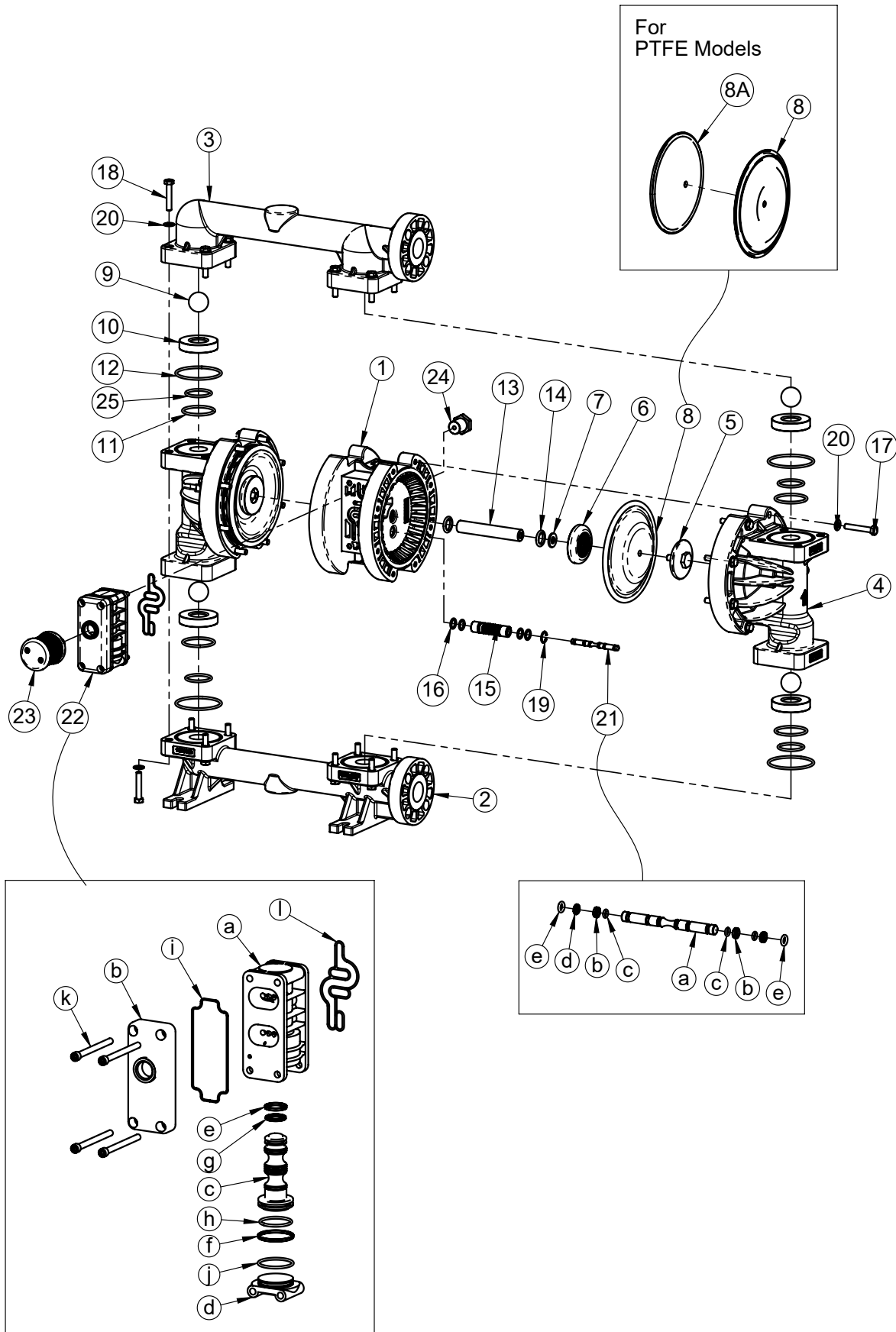

Bill of Materials for TC25-PSX-FEX-XXX

ILLU. NO.	PART NO.	DESCRIPTION	TC25PTSF
1	1870801	Shaft Housing-TC25	1
2	1870802	Inlet Base-TC25	1
3	1870803	Outlet-TC25	1
4	1870804	Outer Chamber-TC25	2
5	1870805	Outer Flange-TC25	2
6	1603012	Inner Flange-TM25/TC25	2
7	1602135	Plain Washer	2
8	1634101	Diaphragm-TC25	2
9	1874102	Ball-TP25	4
10	1872001	Ball Seat-TP25	4
11	1873606	O Ring	4
12	1873607	O Ring	4
13	1872702	Primary Shaft-TC25	1
14	1646001	D Seal	2
15	1672702	Sleeve-TP25/TC25	1
16	1644003	O Ring	4
17	1879009S	Hex Bolt	16
18	1879008S	Hex Bolt	16
19	2004012S	Inernal Circlip	2
20	4699001	Plain Washer	32

ILLU. NO.	PART NO.	DESCRIPTION	TC25PTSF
21	1679804	Secondary Shaft Assembly-TP25	1
a	1672703	Secondary Shaft-TP25/TC25	1
b	2033604	Seal	3
c	2034010	O Ring	3
d	2033605	Seal	1
e	0229030	O Ring	2
22	1649804	Air Valve Assembly-TC15/25	1
a	1640808	Air Valve Body-TC15/25	1
b	1640809	Air Valve Body Cover-TC15/25	1
c	1640810	Air Piston-TC15/25	1
d	1640811	End Cap-TC15/25	1
e	1643606	Ring	5
f	1643607	Ring	1
g	1644004	X Seal	5
h	1644006	O Ring	1
i	1644007	Seal	1
j	1644008	O Ring	1
k	1649003	Allen Bolt	4
l	1644005	Skeleton Seal-TC15/TC15	1
24	1870807	Adapter-TC25	1

Bill of Materials for TC25-PTS-FEX-XXX

ILLU. NO.	PART NO.	DESCRIPTION	TC25PTSF
1	1870801	Shaft Housing-TC25	1
2	1870802	Inlet Base-TC25	1
3	1870803	Outlet-TC25	1
4	1870804	Outer Chamber-TC25	2
5	1870805	Outer Flange-TC25	2
6	1603012	Inner Flange-TM25/TC25	2
7	1602135	Plain Washer	2
8	1873603T	Diaphragm (Full stroke)-TP25/TC25	2
8A	1874104	Backup Diaphragm (Full stroke) - TP25/TC25	2
9	2583616T	Ball-TP25/TC25	4
10	1872001	Ball Seat-TP25	4
11	1873606	O Ring	4
12	1873607	O Ring	4
13	1872702	Primary Shaft-TC25	1
14	1646001	D Seal	2
15	1672702	Sleeve-TP25/TC25	1
16	1644003	O Ring	4
17	1879009S	Hex Bolt	16
18	1879008S	Hex Bolt	16
19	2004012S	Inernal Circlip	2
20	4699001	Plain Washer	32

ILLU. NO.	PART NO.	DESCRIPTION	TC25PTSF
21	1679804	Secondary Shaft Assembly-TP25	1
a	1672703	Secondary Shaft-TP25/TC25	1
b	2033604	Seal	3
c	2034010	O Ring	3
d	2033605	Seal	1
e	0229030	O Ring	2
22	1649804	Air Valve Assembly-TC15/25	1
a	1640808	Air Valve Body-TC15/25	1
b	1640809	Air Valve Body Cover-TC15/25	1
c	1640810	Air Piston-TC15/25	1
d	1640811	End Cap-TC15/25	1
e	1643606	Ring	5
f	1643607	Ring	1
g	1644004	X Seal	5
h	1644006	O Ring	1
i	1644007	Seal	1
j	1644008	O Ring	1
k	1649003	Allen Bolt	4
l	1644005	Skeleton Seal-TC15/TC15	1
23	1640813	Silencer	1
24	1870807	Adapter-TC25	1
25	1644106	O Ring	4

Replacement & Repair Kits for TC25 Series Pump

Item. No.	Part Number	Description	Replacement Kit 1649804	Repair Kit 1879703S	Repair Kit 1879703T
8	1634101	Diaphragm-TC25	-	2	-
8	1873603T	Diaphragm (Full stroke)-TP25	-	-	2
8A	1874104	Backup Diaphragm (Full stroke)-TC25	-	-	2
9	1874102	Ball-TP25	-	4	-
9	2583616T	Ball-TP25/TC25	-	-	4
10	1870806	Ball Seat-TC25	-	4	4
11	1873606	O Ring	-	4	4
12	1873607	O Ring	-	4	4
14	1634002	Bonded Seal-TM25/TC25	-	2	2
16	1644003	O Ring	-	4	4
19	2004012S	Inernal Circlip	-	2	2
21	1679804	Secondary Shaft Assembly-TP25	-	1	1
22	1649804	Air Valve Assembly-TC15/25	1	-	-
c	1640810A	Air Piston Assembly-TC15/25	-	1	1
d	1640811A	End Cap AssemblyTC15/25	-	1	1
l	1644005	Skeleton Seal-TP15/TC15	-	1	1
24	1870807	Adapter-TC25	-	1	1

Dimensional Data

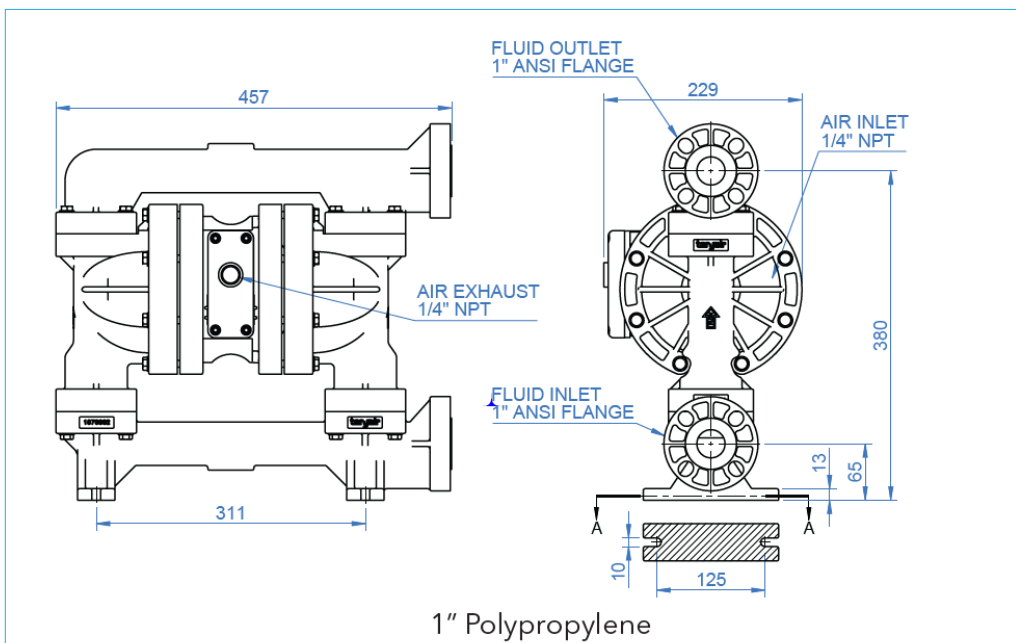

EU DECLARATION OF CONFORMITY

We hereby certify that the Listed Product stipulated below comply with all relevant provisions of the machinery directive (2006/42/EC) and the national laws and regulations adopting this directive.

Description : AIR OPERATED DOUBLE DIAPHRAGM PUMP

Model Number : TC25 Series

Is in conformity with the provisions of the following European Directives: (2006/42/EC) Machinery Safety and Harmonized standards

ISO 12100-1: 2010: Safety of Machinery –general Principles for Design –Risk Assessment and Risk Reduction.

Registered Office : 416 Gundecha Industrial Complex, Akuril Road,
Kandivali East, Mumbai – 400101, Maharashtra, India.

Web site : www.teryair.com

Works : A-1, Tirupati Udyog Nagar, Sativali Road, Vasai East,
Palghar – 401208, Maharashtra, India.

CE certification registration no – C E 16831

Issued by – BMQR Certifications Pvt Ltd.
www.cemarking-india.com

Valid Till – 03/11/2025

Signed for and on behalf of

TERYAIR EQUIPMENT PVT. LTD.



Place of Issue : Vasai



Warranty Certificate

Every product manufactured by Teryair
is built to meet the highest standards of quality.

Teryair warrants that the Products, accessories and parts manufactured or supplied by the company be free from defects in material and workmanship for a period of six months from date of Teryair authorized dealer invoice to customer, or one year from date of Teryair invoice to dealer, whichever is earlier. Failure due to normal wear, misapplication, or abuse is, of course, excluded from this warranty.

Since the use of Teryair products and parts is beyond our control, Teryair cannot guarantee the suitability of any product or part for a particular application and Teryair shall not be liable for any consequential damage or expense arising from the use or misuse of its products on any application. Teryair does not warranty bought out products or components such as electric motors and hardware but will assist in directing warranty queries to the dealer/manufacturer responsible. Teryair responsibility is limited solely to replacement or repair of defective Teryair products or components.

Dealer/End User shall have no right or remedy and Teryair shall have no liability or obligation under the warranty, if: (i) a Product is altered, changed, modified or tampered with in any way, (ii) a Product is damaged after deposit with the transporter for shipment; (iii) a Product is not properly preserved, packaged, stored, processed or handled after receipt; (iv) a Product is not used and maintained in accordance with Teryair's recommended operating and maintenance manuals, instructions and procedures, if any; (v) a Product is not properly incorporated or installed in, or not properly combined with, an Other Product; (vi) the issue with a Product is directly or indirectly attributable to, or directly or indirectly results from or arises out of, a failure, substandard performance or other issue with another product, material, component or part not supplied by Teryair; (vii) the issue with a Product is directly or indirectly attributable to, or directly or indirectly results from or arises out of, compliance with any design, specification or other specific requirement of Dealer/End User; (viii) a Product is used in a manner, with a substance or for a purpose other than the normal manner, substance and purpose for which it is intended or is otherwise subjected to abnormal use or service; (ix) a Product is subjected to a power surge, brown out or other similar occurrence; (x) the issue with a Product is directly or indirectly attributable to, or directly or indirectly results from or arises out of, normal wear and tear of such Product (including, without limitation, things such as worn seals, diaphragms, balls, O rings, gaskets, chisels, cutters, hoses and other such wearing components; (xi) the issue with a Product is directly or indirectly

A handwritten signature in blue ink, appearing to read "M. Yadav", is written over a horizontal line.

M Yadav, Q.A. Manager

(Company Seal)

This page is intentionally
Left blank.