

Operation and Maintenance Guide

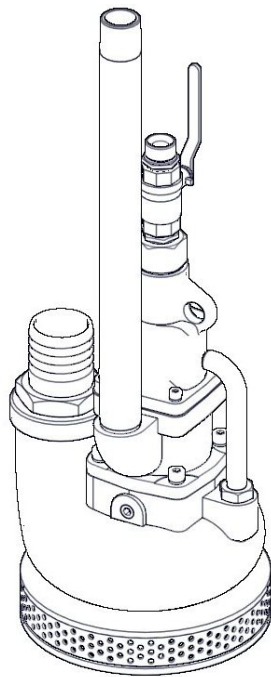

SP - 10

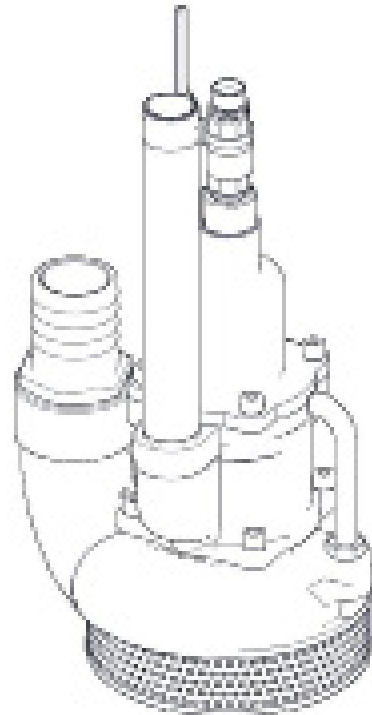

SP - 25

Models	Descriptions	IMPA Number
SP10	Pneumatic Submersible Pump 2"	59 16 35
SP25	Pneumatic Submersible Pump 2-½"	59 16 36

Read this manual carefully before installing, operating or servicing this equipment. It's the responsibility of the employer to ensure this manual is read by the operator. Please preserve this manual.

Table of Contents

3	Introduction
3	Technical Data
3	Safety Instructions
4	Operating Instructions
5	Suggested Lubricants
5	Troubleshooting
6	Diassembly and Re-assembly of SP10
7	Bill of Materials for SP-10
8	Exploded View for SP 10 Pump
9	Exploded View Detail A for SP-10 Pump
10	Exploded View Detail B & Detail C for SP-10 Pump
11	Diassembly and Re-assembly of SP25
12	Exploded View for SP 25 Pump
13	Exploded View Detail A for SP-25 Pump
14	Exploded View Detail B & Detail C for SP-25 Pump
15	Bill of Materials for SP-25
16	Dimensional Data
16	Repair Kits for SP-10 & SP-25
17	Repair Kits for SP-10
18	Repair Kits for SP-25
19	Eu Declaration Of Conformity
20	Warranty Certificate

Introduction

Teryair Pneumatic Centrifugal Pumps are used to empty ballast tanks, bilge wells, etc. Often used for draining cargo holds during and after the washing procedure. Teryair Centrifugal pumps have a small cross-section and hence can be lowered into areas having small access hatches. Especially preferred where an eclectic spark may risk ignition or explosion. Required air pressure is 059 MPa (6kgf/cm2).

Technical Data

Specification	SP-10	SP-25
Output in m ³ /Hr	48	60
Total Head in mtrs	27	24
Air Hose	¾" NPT	¾" NPT
Air exhaust	1" NPT	1¼ BSPP
Fluid Outlet	2" Hose	2½" Hose
Air Consumption, m ³ /min	2.7	3.5
Min. opening pump will enter	204mm x 230mm	210mm x 305mm
Height	340mm	392mm
Weight, Kgs	22	32

Intended Use

Pneumatic Submersible pumps are intended for use de-watering ,transfer of fluids such as clear and sea water, marine emptying of ballast tanks, damming cargo holds and pumping of sea water from bilges and holds.

It is a single stage centrifugal unit driven by powerful vane motor. Also double seals protect bearing and motor from water & mud, and integral oiler provides continuous lubrication. Follow the instructions mentioned here to enhance the life and performance of the pump.

Warning

This manual must be read and the operating instructions carefully followed.

Warning

Operators under eighteen not allowed to operate this Pump. Operators must be made familiar with the instructions in this manual before attempting to operate the pump.

Caution

Use only genuine Teryair or Teryair approved accessories.

Caution

Completely turn off the Pump and disconnect air supply line before attempting any service. Read Assembly and Disassembly instructions

Safety Instructions

Following symbols are used through out this manual.

Warning

Warning: If not followed could cause personal injuries

Caution

If not followed could result in damage to equipment.

**Caution**

A regular maintenance after every 500 hours of operation will greatly add to the durability of the pump.

**Warning**

Take care not to exceed the maximum 6 bar (90 psi) supply air pressure. Use a filter and regulator and lubricator as close to the Pump inlet as operation will allow ensuring a clean and regulated and lubricated air flow.

**Caution**

Keep hoses in good condition. Check hoses for signs of wear, cracks & bulges and ensure that they are secure. Accidental disconnection while hose is pressurized makes the hose whip and can be a safety hazard.

**Caution**

Please check the hose connection prior to starting pump.

Store these pump in secure & dry environment.

Do not allow the pump to run unattended.

Do not modify this pump in any way as this will invalidate the warranty and could lead to serious injury.

Operating Instructions

Sump pump is rugged dependable equipment designed to give you years of satisfactory service. Follow the instructions mentioned here to enhance life and performance of your pump.

Daily Before Operating

Disconnect and pour in 1 to 2 ounces of recommended oil into the pump and reconnect hose after blowing out any accumulated dirt in the hose line before connection

Lubrication Requirements

Always install a line lubricator on the air line as close to the pump as possible. A Filter Regulator Lubricator unit (FRL) is strongly recommended. Keep the lubricator bowl topped up with recommended grade of oil and check that the oil is reaching the Pump. Running the Pump without lubrication is likely to cause damage to the components causing premature replacement.

Air Supply

The pump work best at 6 bar (90 psi) air pressure. The air should be clean, dry and lubricated. Install a FRL unit as close as operation will permit.

Hoses

Daily before operation check the hoses, especially the high pressure hoses for damage or leaks.

Use genuine Teryair spares and if possible mention the serial number of the pump when ordering spares.

Storage

When storing sump pump for any length of time precautions should be taken to prevent corrosion and to maintain pump in a serviceable condition.

Remove discharge and exhaust hose or pipe and run pump out of water to blow out all moisture

Remove air line and pour a small amount of rust resistant oil in live air inlet.

Re- connect hose and idle motor a few minutes to carry oil to all internal parts.

Remove air hose and plug live air inlet and air exhaust port with corks.

Wipe out side of pump with rust resisting oil. Wrap pump in oiled paper and pack in covered box.

Store pump in dry place.

Suggested Lubricants

Brand	Above 27 Deg C (From 5 Deg C to 27 Deg C	Below 5 Deg C
Shell	Toona R.72	Toona R.41	Toona R.27
Mobil	Almo 529	Almo 527	Almo 525
Esso	-- -- -- --	Arox EP.65	Arox EP.45
Caltex	Rando Oil 100	Rando Oil 100	Rando Oil 46
CP	-- -- -- --	-- -- -- --	Airolene Tool Oil
Texaco	Regal Oil F (R&O)	Regal Oil PE (P&E)	Regal Oil PE (R&O)
Daltron	Silkolene 881	Silkolene 548/T	Silkolene 733
Burmah Castrol	Castrol RD Oil 3	Castrol RD Oil Light	Megna SPX
Duckham	Garnet 7	Garnet 6	Zero Fio 5
Sternol	Merlin 87	Merlin 71	Merlin 54
Petrofina	Purifoc 53	Purifoc 46	Purifoc 32
Chevron	Vistac Oil 18X	Vistac Oil 19X	Vistac Oil 9X
Indoil	Servo Spyn -22	-- -- -- --	-- -- -- --

Troubleshooting

Serial No	Description	Causes
1	Pump stops and will not start	Insufficient Air Pressure Check air pressure is as recommended at the pump air inlet
		Air Filter Blocked Check if debris has clogged the inlet filter on the FRL unit/pump inlet air valve (some models have air filter on the air inlet valve) and ensure clear passage of air
		Internal damage or excessive wear on components Proceed to dismantle the pump, examine component for wear, replace any worn components, re assemble carefully as instructed in this manual and re start the pump.
2	Pump runs slowly, poor delivery.	Insufficient or wrong lubricant in the air supply. Ensure that the lubricant is as per the recommended chart, a thicker lubricant often makes the air valve work sluggishly.
		Internal damage or excessive wear on components Proceed to dismantle the pump, examine component for wear, replace any worn components, reassemble carefully as instructed in this manual and re start the pump.
3	Motor is jammed.	Worn or damaged rotor blades Dis -assemble governor housing (7) and motor housing (35). Clean all parts in a light solvent. Replace worn or damaged parts and reassemble.

Disassembly and Re-assembly of SP10

Disassembly and Re assembly SP10

Disconnect the air supply to the pump.

- a. Unscrew and remove Gate Valve (1), Exhaust Pipe (49) and Discharge Nipple (48) from Impeller Housing (46).
- b. Unscrew Allen Bolt (33) with Spring Washer (34) to separate Motor Housing (35) from Impeller Housing (46).
- c. Now unscrew Allen Bolt (8) with Spring Washer (9) to separate Governor Housing (7) & Gasket (10) from Motor Housing (35) and replace it with new one. (If found damaged)
- d. Unscrew Hex Bolt (44) with Spacer (43) to remove Impeller (42) and Rotor Key (41) from Rotor (28).
- e. Now remove motor assembly (Parts in Detail B) from Motor Housing (35).
- f. Unscrew Governor Body (22) (Clockwise) from Rotor (28). Now remove Pin (21) from Governor Body (22) and remove Governor Weight (20) and replace it with new one. (If found damaged)
- g. Remove Upper End Plate (24) from Rotor Body (28) to remove Ball Bearing (23) & Spacer (27) and replace with new one (If found damaged)
- h. Remove Cylinder (25) and Rotor Blades (29) from Rotor (28). Now remove Roll Pin (26) from Cylinder (25) and replace with new one. (If found damaged)
- i. Now press Rotor (28) from Lower End Plate (31) side to remove Rotor (28). Now remove Ball Bearing (32) from Lower End Plate (31) and replace it with new ones. (If found damaged)
- j. Now remove Impeller Sleeve (40) from Upper Wear Plate (38) and remove O-ring (50) & Shim (51) and replace it with new ones. (If found damaged)
- k. Unscrew CSK Screw (39) from Upper Wear Plate (38) from Impeller Housing (46).
- l. l) Now remove Oil seals (37) and O-rings (36) from Motor Housing (1) and replace it with new ones. (If found worn-out)
- m. Now insert a 6 mm diameter rod (1/4") in to the holes in the underside of Impeller Housing (46) and evenly tap the Lower Wear Plate (42) out of the housing.
- n. Now unscrew Governor Valve Cage (17) from Governor Housing (7) . Now unscrew Bushing (18) from Governor Valve Cage (17).
- o. Now remove Internal Circlip (11) from Governor Valve Cage (17) using circlip remover. Now remove Spring Retainer (12), Spring (13), Governor valve (14) & Pin (15) from Governor Valve Cage (17) and replace it with new ones. (If found damaged)
- p. Now remove Internal Circlip (2) from Air Inlet Bushing (4) using circlip remover. Now remove Air Strainer (3) from Air Inlet Bushing (4), O-ring (5) and O-ring (6) and replace it with new ones. (If found damaged)
- q. Unscrew Air Inlet Bushing (4) from Governor Housing (7). Now remove O-ring (5) an O-ring (6) from Governor Housing (7).
- r. When re - assembling the pump, there should be a clearance of 0.15 mm (0.007") to 0.3 mm (0.012") add the appropriate thickness of shims under the Lower End Plate (31). Insure that the shims slots are aligned with the three knockout holes in the Impeller Housing (46). When assembling Motor Housing (35) the Upper End Plate (24) must protrude above the motor housing (35), between 0.035 mm (0.001") and 0.075 mm (0.003"). If not add shims - similar to wave washers.
- s. Ensure while assembly of Upper End Plate (24) with Cylinder (25) that holes are aligned.
- t. Now follow the above steps in reverse manner to reassemble the Sump Pump.

Bill of Materials for SP-10

Illustration Number	Part Number	Description	SP-10	Illustration Number	Part Number	Description	SP-10
1	1999750	GATE VALVE	1	26	1995036	ROLL PIN (LOWER/ UPPER)	2
2	5009043	INTERNAL CIRCLIP FOR AIR STRAINER	1	27	1992115	SPACER (UPPER BEARING)	1
3	1993828	AIR STRAINER	1	28	1992113	ROTOR	1
4	1992114	AIR INLET BUSHING	1	29	1993929	ROTOR BLADE	4
5	1994056	O' RING FOR GOVERNOR HOUSING	1	30	1992117	SPACER FOR LOWER BEARING	1
6	1994034	O' RING FOR AIR INLET BUSHING	1	31	1990563	LOWER END PLATE	1
7	1990565	GOVERNOR HOUSING	1	32	1995035	BALL BEARING(LOWER)	1
8	1999048	ALLEN BOLT	4	33	1999046	ALLEN BOLT	4
9	5009048	SPRING WASHER FOR GOVERNOR HOUSING	4	34	1999047	SPRING WASHER	4
10	1994033	GASKET FOR GOVERNOR HOUSING	1	35	1990506	MOTOR HOUSING	1
11	2004012	INTERNAL CIRCLIP FOR SPRING RETAINER	1	36	1994030	O' RING FOR MOTOR HOUSING	2
12	1995041	SPRING RETAINER	1	37	1994060	OIL SEAL FOR SPINDLE	2
13	1995040	SPRING FOR GOVERNOR VALVE	1	38	1992112	WEAR PLATE UPPER	1
14	1992121	GOVERNOR VALVE	1	39	1999043	C.S.K. SCREW FOR UPPER WEAR PLATE	4
15	1992120	PIN FOR GOVERNOR VALVE	1	40	1992111	IMPELLER SLEEVE	1
16	1994031	O RING FOR VALVE CAGE	1	41	1995039	ROTOR KEY	1
17	1992527	GOVERNOR VALVE CAGE	1	42	1999801	ASSEMBLY OF IMPELLER AND LOWER WEAR PLATE	1
18	1992119	BUSHING FOR GOVERNOR VALVE PIN	1	43	1992110	SPACER IMPELLER RETAINER	1
19	1992125	PUSH PIN	1	44	1999042	HEX. BOLT FOR IMPELLER RETAINER	1
20	1992122	GOVERNOR WEIGHT	2	46	1890508	IMPELLER HOUSING	1
21	1992166	PIN FOR GOV. WEIGHT	2	47	1892114	SUMP SCREEN	1
22	1992124	GOVERNOR BODY	1	48	1992109	DISCHARGE NIPPLE	1
23	1995038	BALL BEARING(UPPER)	1	49	1999045	EXHAUST PIPE	1
24	1990564	UPPER END PLATE	1	50	1904051	O' RING FOR IMPELLER	1
25	1991207	CYLINDER	1	51	1899001	PHILIPS C.S.K. SCREW	3
				52	1999052	PIPE PLUG	1
				53	1909030	LOCK NUT FOR HANDLE	1
				54	1902125	HANDLE	1

Exploded View for SP 10 Pump

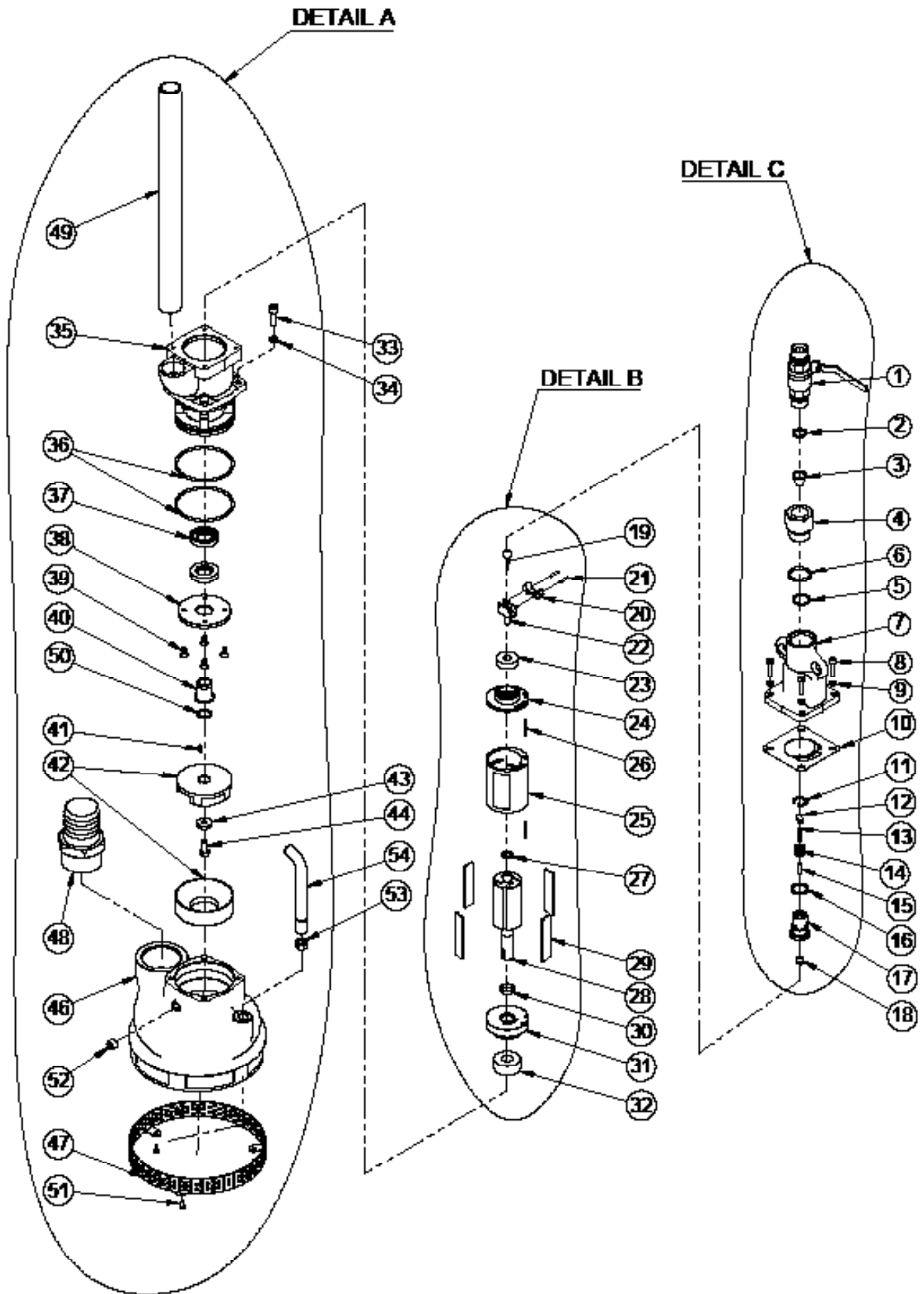

Exploded View Detail A for SP-10 Pump

DETAIL A

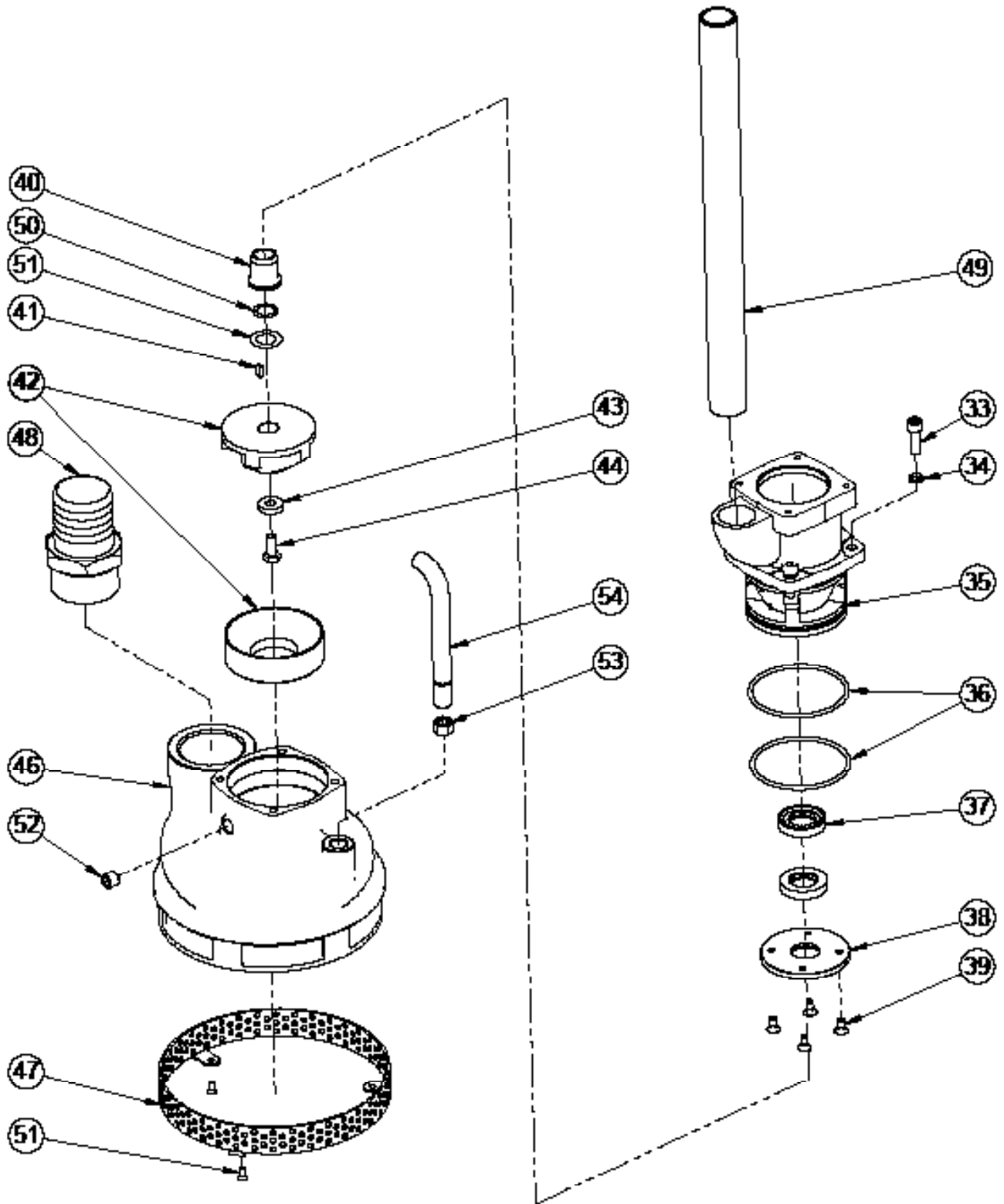

Exploded View Detail B & Detail C for SP-10 Pump

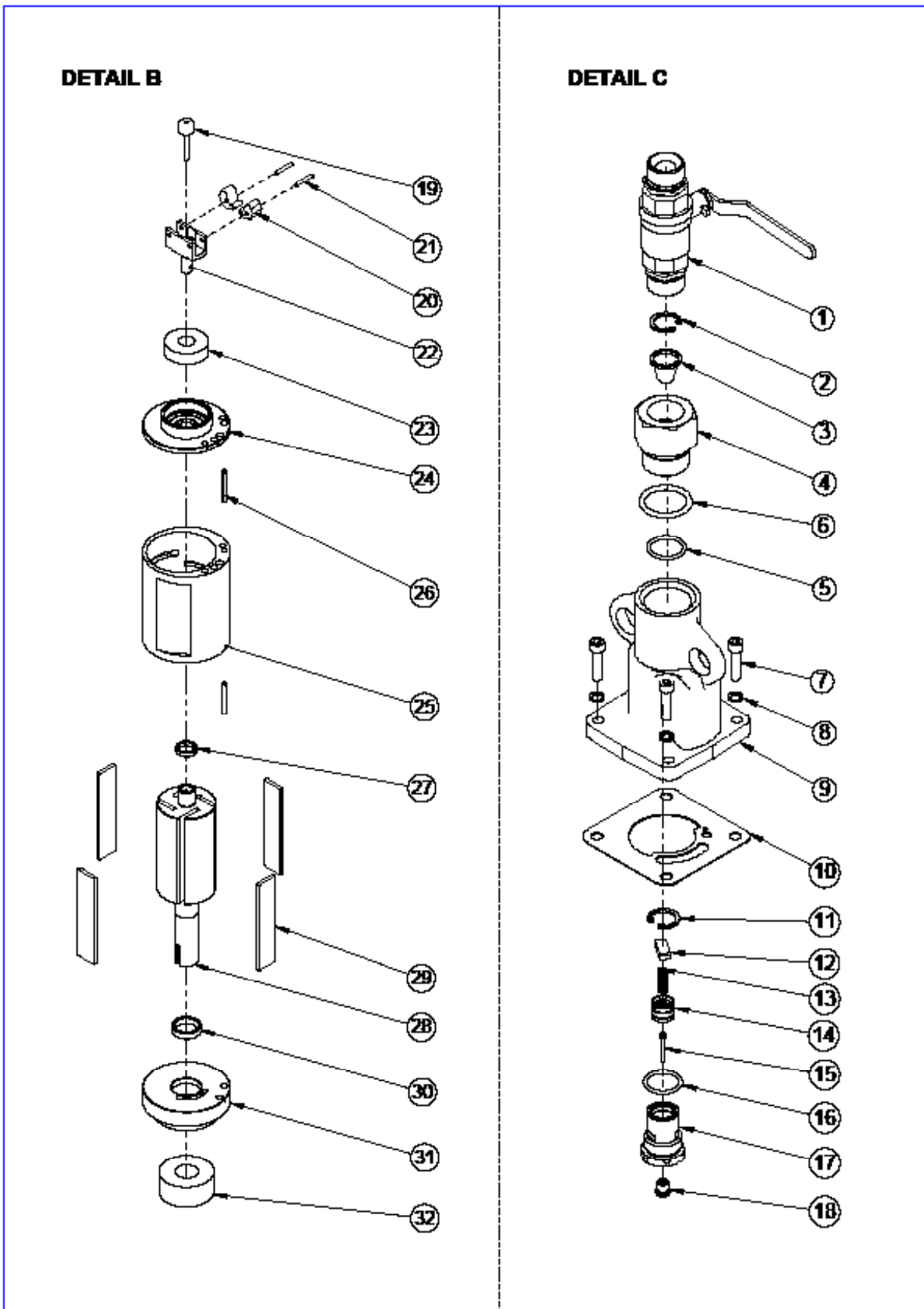

Diassembly and Re-assembly of SP25

Disassembly and Re assembly SP25

Disconnect the air supply to the pump.

- a. Unscrew and remove Gate Valve (1), Exhaust Pipe (36), and Discharge Nipple (47) from Impeller Housing (48).
- b. Unscrew Allen Bolt (38) with Spring Washer (8) to separate Motor Housing (37) from Impeller Housing (48).
- c. Now Unscrew Allen Bolt (7) with Spring Washer (8) to separate Governor Housing (6) from Motor Housing (37) and replace it with a new one. (If found damaged)
- d. Unscrew Impeller (43) from Rotor Body (25) and replace it with a new one. (If found damaged).
- e. Now remove motor assembly (Parts in Detail B) from Motor Housing (37).
- f. Unscrew Governor Body (18) (Clockwise) from Rotor Body (25). Now remove Pin (19) from Governor Body (18) to remove Governor Weight (17) and replace it with a new one. (If found damaged)
- g. Remove Upper-End Plate (22) from Rotor Body (25) to remove Ball Bearing (20) & Spacer (23) from Upper-End Plate (22) and replace with a new one (If found damaged)
- h. Remove Cylinder (29) and Rotor Blades (24) from Rotor (25). Now remove Roll Pin (28) from Cylinder (25) and replace it with a new one. (If found damaged)
- i. Now push Rotor Body (25) from Lower End Plate (30) side to remove Rotor Body (25). Now remove Impeller Sleeve (41) from Upper Wear Plate (40) and remove O-ring (42) and replace it with new ones. (If found damaged)
- j. Now remove Ball Bearing (32) and O-ring (31) from Lower End Plate (30) and replace them with new ones. (If found damaged)
- k. Now remove Spacer for Rotor (27) and O-ring (26) from Rotor Body (25).
- l. Now remove the Upper Wear plate (40), O-ring (39), and Oil Seal (34) from Motor Housing (37) and replace them with new ones. (If found damaged)
- m. Now remove Seal Plate (35), Oil seal (34), Gasket (33), and O-ring (21) from Motor Housing (37) and replace it with new ones. (If found damaged)
- n. Now remove Internal Circlip (15) from Governor Housing (6) using Circlip remover to remove Governor Valve Cage (14).
- o. Now remove O-ring (5) from Governor Valve Cage (14)
- p. Now remove Internal Circlip (9) from Governor Valve Cage (14) using circlip remover. Now remove Spring Retainer (10), spring (11), Governor Valve (12) & Pin (13) from Governor Valve Cage (14) and replace them with new ones. (If found damaged)
- q. Now remove Internal Circlip (2) from Air Inlet Bushing (4) using circlip remover. Now remove Air Strainer (3) from Air Inlet Bushing (4)
- r. Now unscrew Air Inlet Bushing (4) from Governor Housing (6) and O-ring (5) from Air Inlet Bushing (4) replace it with new ones. (If found damaged)
- s. Now insert a 6 mm diameter rod (1/4") into the holes in the underside of impeller housing (46) and evenly tap the Lower Wear Plate out of the housing.
- t. When reassembling the pump, there should be a clearance of 0.15 mm (0.007") to 0.3 mm (0.012") add the appropriate thickness of shims under the lower wear plate (30). Insure that the shims slots are aligned with the three knockout holes in the impeller housing (48). When assembling Motor Housing (37) the Upper-End Plate (22) must protrude above the Motor Housing (37), between 0.035 mm (0.001") and 0.075 mm (0.003"). If not add shims - similar to wave washers.
- u. Ensure while assembly of Upper-End Plate (22) with Cylinder (29) that holes are aligned.
- v. Now follow the above steps in reverse manner to reassemble the Sump Pump.

Exploded View for SP 25 Pump

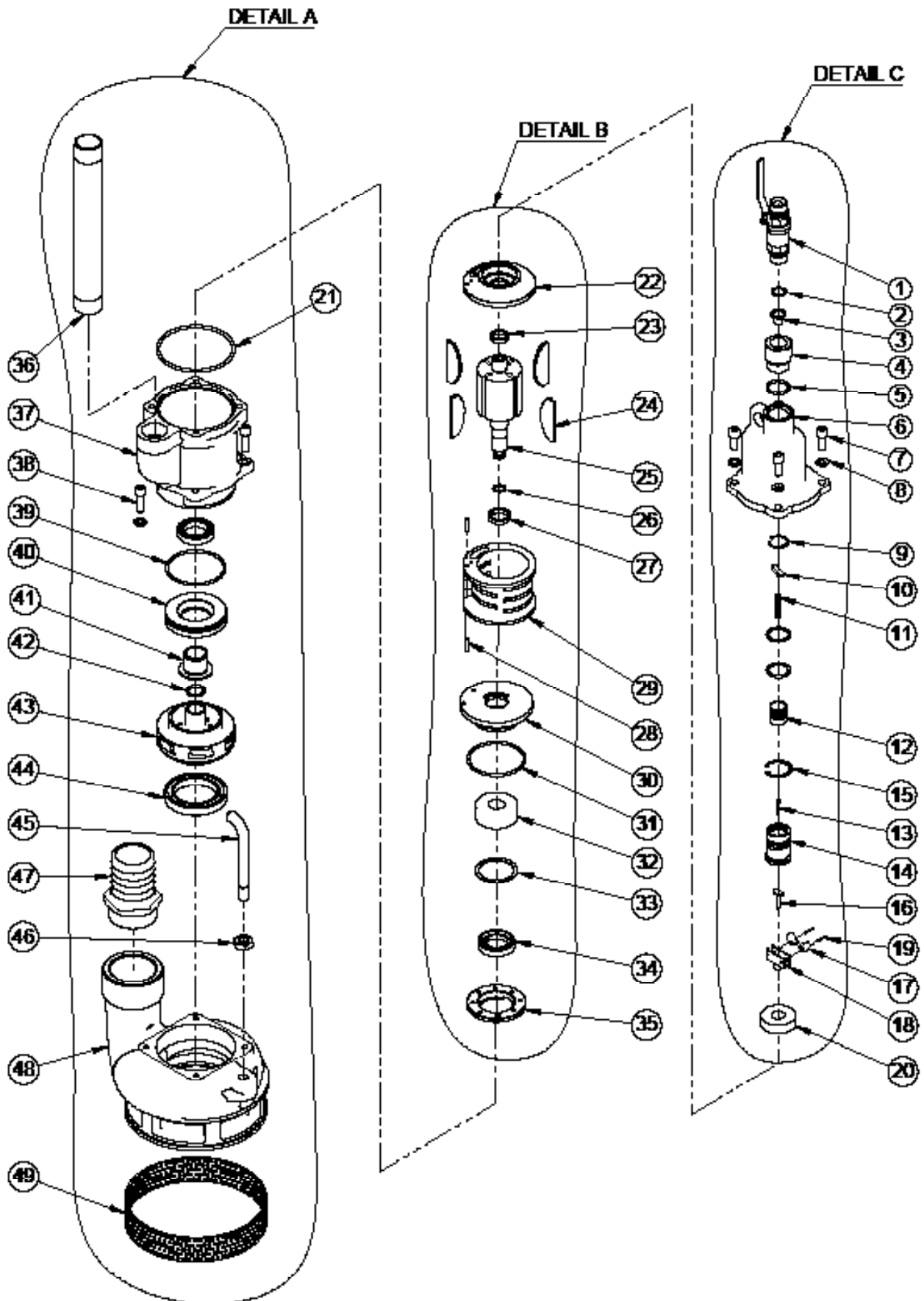

Exploded View Detail A for SP-25 Pump

DETAIL A

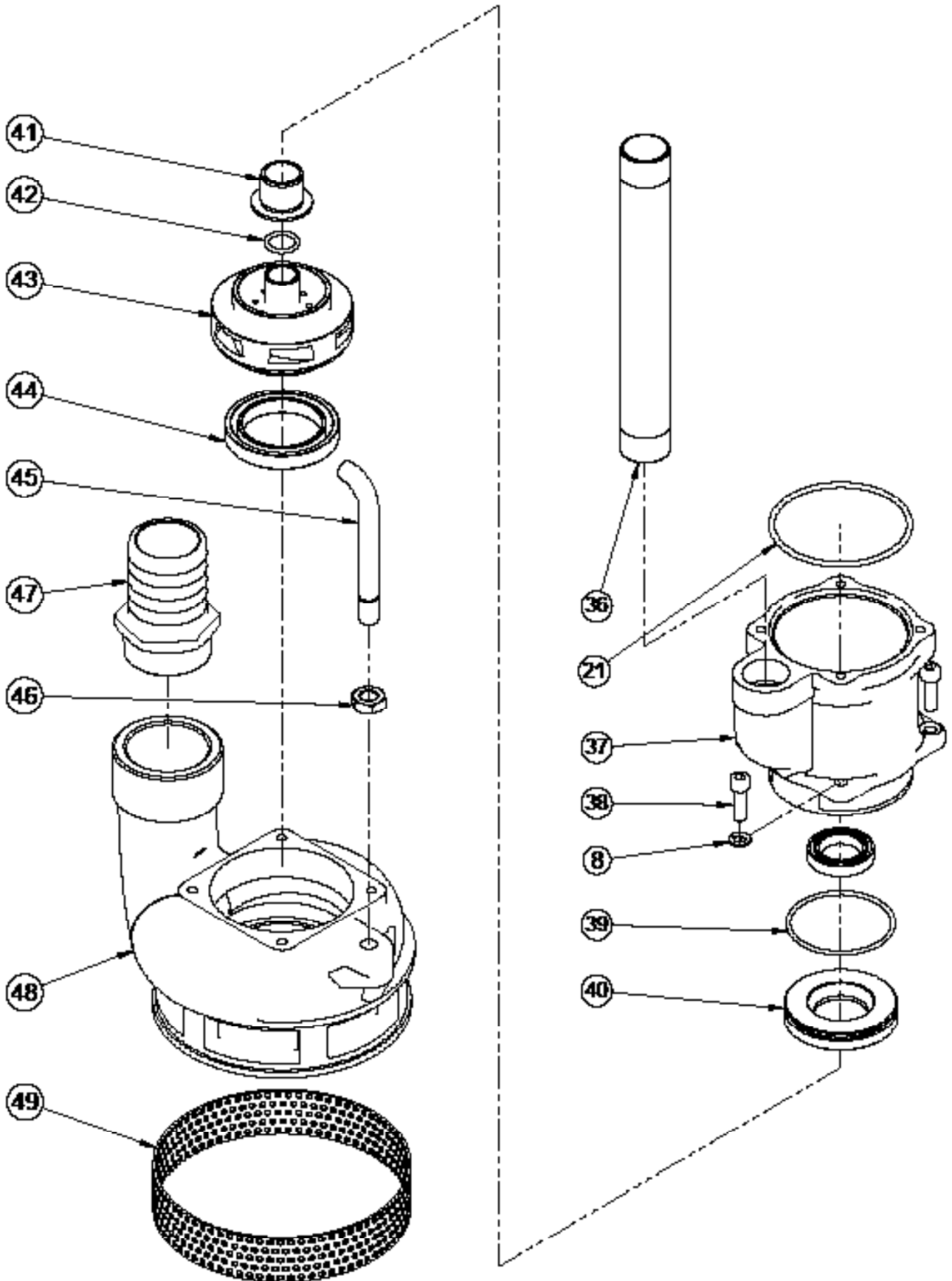

Exploded View Detail B & Detail C for SP-25 Pump

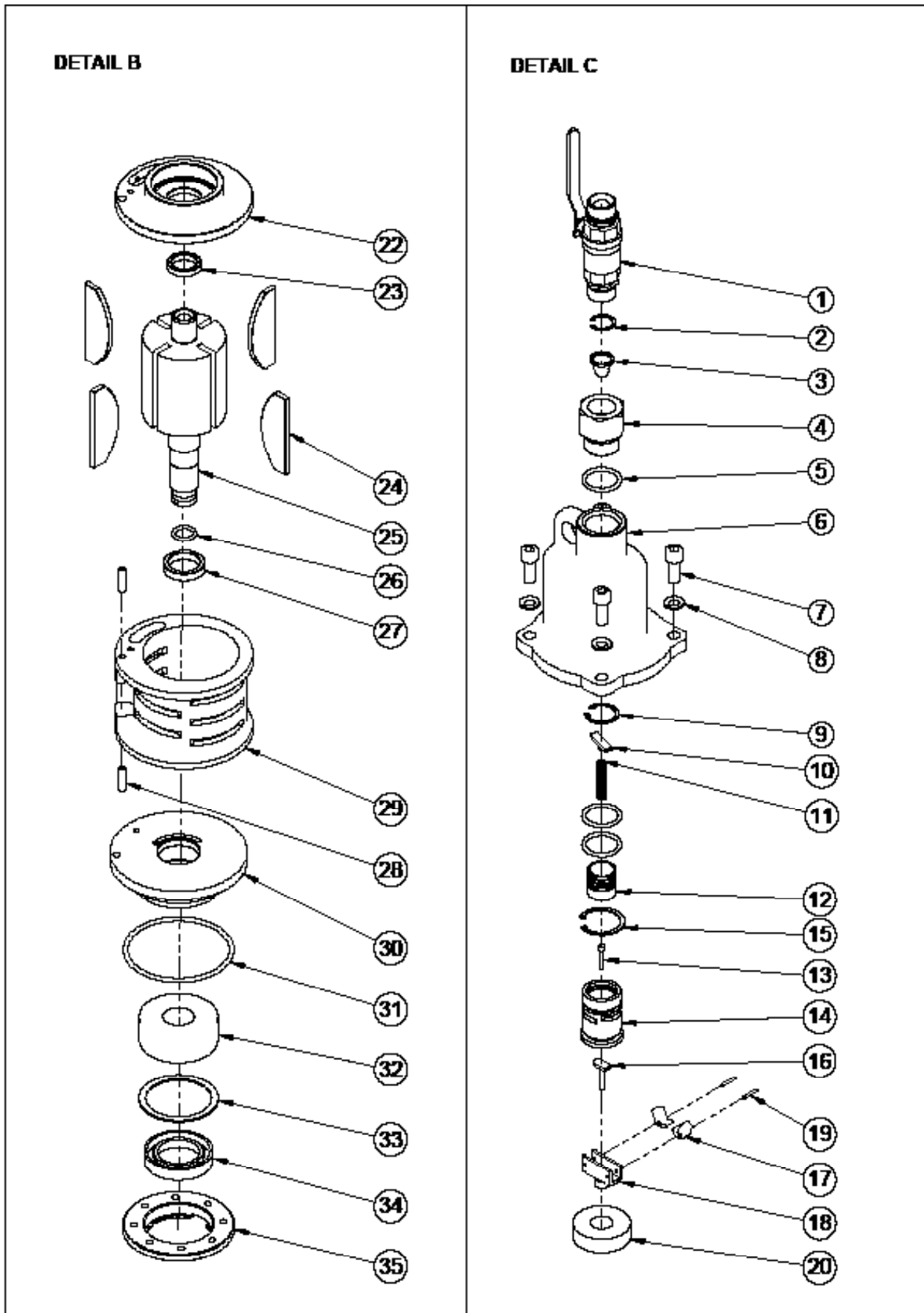

Bill of Materials for SP-25

Illustration Number	Part Number	Description	SP-25	Illustration Number	Part Number	Description	SP-25
1	1999750	GATE VALVE	1	26	1904051	O' RING FOR IMPELLER	1
2	5009043	INTERNAL CIRCLIP FOR AIR STRAINER	1	27	1902122	SPACER ROTOR BEARING(LOWER)	1
3	1993828	AIR STRAINER	1	28	3200135	ROLL PIN FOR CYLINDER	2
4	1992114	AIR INLET BUSHING	1	29	1900505	CYLINDER	1
5	1994034	O' RING FOR AIR INLET BUSHING	3	30	1900507	LOWER END PLATE	1
6	1900503	GOVERNOR HOUSING	1	31	1904022	O' RING FOR LOWER END PLATE	1
7	1909066	ALLEN BOLT	4	32	1905053	BALL BEARING-LOWER	1
8	2109035	SPRING WASHER	8	33	1904048	GASKET FOR SEAL PLATE	1
9	1909098	INTERNAL CIRCLIP FOR VALVE CAGE	1	34	1909063	"OIL SEAL FOR SEAL PLATE & UPPER WEAR PLATE"	2
10	1905068	SPRING RETAINER	1	35	1900506	SEAL PLATE	1
11	1905154	SPRING FOR GOVERNOR VALVE	1	36	1909065	EXHAUST PIPE	1
12	1902115	GOVERNOR VALVE	1	37	1900502	MOTOR HOUSING	1
13	1902116	PIN FOR GOVERNOR VALVE	1	38	1909027	"SOCKET HEAD SCREW FOR MOTOR HOUSING"	4
14	1902569	GOVERNOR VALVE CAGE	1	39	1994030	O' RING FOR UPPER WEAR PLATE	1
15	2009007S	INTERNAL CIRCLIP	1	40	1900509	UPPER WEAR PLATE	1
16	1902118	PIN FOR GOVERNOR BODY	1	41	1902123	IMPELLER SLEEVE	1
17	1902119	GOVERNOR WEIGHT	2	42	1504052	O RING FOR IMPELLER SLEEVE	1
18	1902117	GOVERNOR BODY	1	43	1900504	IMPELLER	1
19	1992166	PIN FOR GOV. WEIGHT	2	44	1900510	LOWER WEAR PLATE	1
20	1905052	BALL BEARING-UPPER	1	45	1902125	HANDLE	1
21	1904023	O' RING FOR UPPER END PLATE	1	46	1909030	LOCK NUT FOR HANDLE	1
22	1900508	UPPER END PLATE	1	47	1902128	DISCHARGE NIPPLE	1
23	1902120	SPACER ROTOR BEARING(UPPER)	1	48	1900501	IMPELLER HOUSING	1
24	1903938	ROTOR BLADE	4	49	1903102	SUMP SCREEN	1
25	1902121	ROTOR BODY	1				

Dimensional Data

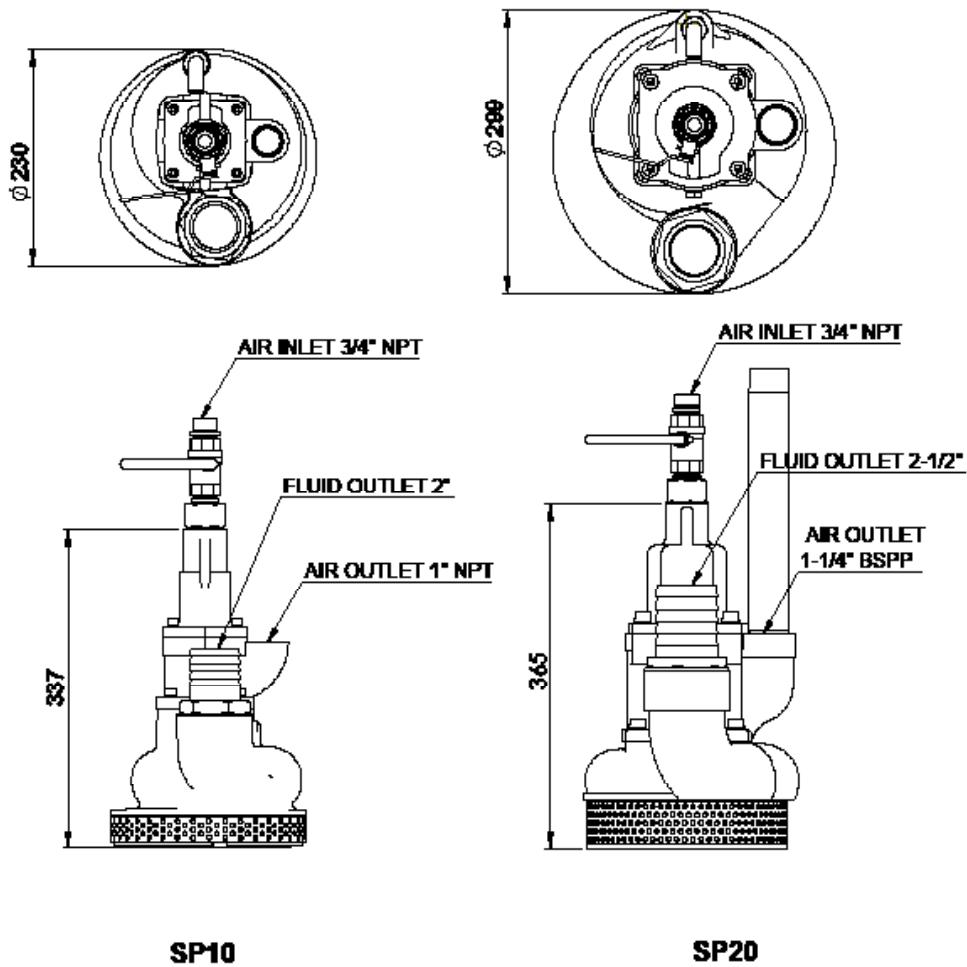

Repair Kits for SP-10 & SP-25

Repair KIT Ordering No	Suitable for
199 97 53	SP 10
190 97 11	SP 25

Repair Kits for SP-10

Illu. No.	Part No.	Description	SP 10
			199 97 55 Repair Kit
1	1999750	GATE VALVE WITH	1
6	1994034	O' RING FOR AIR INLET BUSHING	1
10	1994033	GASKET FOR GOVERNOR HOUSING	1
12	1995041	SPRING RETAINER	1
13	1995040	SPRING FOR GOVERNOR VALVE	1
14	1992121	GOVERNOR VALVE	1
15	1992120	PIN FOR GOVERNOR VALVE	1
16	1994031	O RING FOR VALVE CAGE	1
17	1992527	GOVERNOR VALVE CAGE	1
18	1992119	BUSHING FOR GOVERNOR VALVE PIN	1
19	1992125	PUSH PIN	1
20	1992122	GOVERNOR WEIGHT	2
21	1992166	PIN FOR GOV. WEIGHT	2
22	1992124	GOVERNOR BODY	1
23	1995038	BALL BEARING(UPPER)	1
26	1995036	ROLL PIN (LOWER/ UPPER)	2
29	1993929	ROTOR BLADE	4
32	1995035	BALL BEARING(LOWER)	1
36	1994030	O' RING FOR MOTOR HOUSING	2
37	1994060	OIL SEAL FOR SPINDLE	2
42	1999801	ASSEMBLY OF IMPELLER AND LOWER WEAR PLATE	1
44	1999042	HEX. BOLT FOR IMPELLER RETAINER	1
23	199 50 38	BALL BRG	1
24	199 97 50	AIR COCK ASSEMBLY WITH ADAPTORS	1

Repair Kits for SP-25

Illu. No.	Part No.	Description	SP 25
			190 97 11 Repair Kit
1	1999750	GATE VALVE	1
5	1994034	O' RING FOR AIR INLET BUSHING	3
7	1909066	ALLEN BOLT	4
8	2109035	SPRING WASHER A10	8
9	1909098	INTERNAL CIRCLIP FOR VALVE CAGE	1
10	1905068	SPRING RETAINER	1
11	1905154	SPRING FOR GOVERNOR VALVE	1
12	1902115	GOVERNOR VALVE	1
13	1902116	PIN FOR GOVERNOR VALVE	1
14	1902569	GOVERNOR VALVE CAGE	1
15	2009007S	INTERNAL CIRCLIP	1
16	1902118	PIN FOR GOVERNOR BODY	1
17	1902119	GOVERNOR WEIGHT	2
18	1902117	GOVERNOR BODY	1
19	1992166	PIN FOR GOV. WEIGHT	2
20	1905052	BALL BEARING-UPPER	1
21	1904023	O' RING FOR UPPER END PLATE	1
24	1903938	ROTOR BLADE	4
26	1904051	O' RING FOR IMPELLER	1
28	3200135	ROLL PIN FOR CYLINDER	2
31	1904022	O' RING FOR LOWER END PLATE	1
32	1905053	BALL BEARING-LOWER	1
33	1904048	GASKET FOR SEAL PLATE	1
34	1909063	"OIL SEAL FOR SEAL PLATE & UPPER WEAR PLATE"	2
38	1909027	"SOCKET HEAD SCREW FOR MOTOR HOUSING"	4
39	1994030	O' RING FOR UPPER WEAR PLATE	1
43	1900504	IMPELLER	1

EU DECLARATION OF CONFORMITY

We hereby certify that the Listed Product stipulated below comply with all relevant provisions of the machinery directive (2006/42/EC) and the national laws and regulations adopting this directive.

Description : Pneumatic Submersible Pump

Model Number : SP Series

Is in conformity with the provisions of the following European Directives: (2006/42/EC) Machinery Safety and Harmonized standards

ISO 12100-1: 2010: Safety of Machinery –general Principles for Design –Risk Assessment and Risk Reduction.

Registered Office : 416 Gundecha Industrial Complex, Akuril Road,
Kandivali East, Mumbai – 400101, Maharashtra, India.

Web site : www.teryair.com

Works : A-1, Tirupati Udyog Nagar, Sativali Road, Vasai East,
Palghar – 401208, Maharashtra, India.

CE certification registration no – C E 16831

Issued by – BMQR Certifications Pvt Ltd.
www.cemarking-india.com

Valid Till – 03/11/2025

Signed for and on behalf of

TERYAIR EQUIPMENT PVT. LTD.



Place of Issue : Vasai



Warranty Certificate

Every product manufactured by Teryair
is built to meet the highest standards of quality.

Teryair warrants that the Products, accessories and parts manufactured or supplied by the company be free from defects in material and workmanship for a period of six months from date of Teryair authorized dealer invoice to customer, or one year from date of Teryair invoice to dealer, whichever is earlier. Failure due to normal wear, misapplication, or abuse is, of course, excluded from this warranty.

Since the use of Teryair products and parts is beyond our control, Teryair cannot guarantee the suitability of any product or part for a particular application and Teryair shall not be liable for any consequential damage or expense arising from the use or misuse of its products on any application.

Teryair does not warranty bought out products or components such as electric motors and hardware but will assist in directing warranty queries to the dealer/manufacture responsible. Teryair responsibility is limited solely to replacement or repair of defective Teryair products or components.

Dealer/End User shall have no right or remedy and Teryair shall have no liability or obligation under the warranty, if: (i) a Product is altered, changed, modified or tampered with in any way; (ii) a Product is damaged after deposit with the transporter for shipment; (iii) a Product is not properly preserved, packaged, stored, processed or handled after receipt; (iv) a Product is not used and maintained in accordance with Teryair's recommended operating and maintenance manuals, instructions and procedures, if any; (v) a Product is not properly incorporated or installed in, or not properly combined with, an Other Product; (vi) the issue with a Product is directly or indirectly attributable to, or directly or indirectly results from or arises out of, a failure, substandard performance or other issue with another product, material, component or part not supplied by Teryair; (vii) the issue with a Product is directly or indirectly attributable to, or directly or indirectly results from or arises out of, compliance with any design, specification or other specific requirement of Dealer/End User; (viii) a Product is used in a manner, with a substance or for a purpose other than the normal manner, substance and purpose for which it is intended or is otherwise subjected to abnormal use or service; (ix) a Product is subjected to a power surge, brown out or other similar occurrence; (x) the issue with a Product is directly or indirectly attributable to, or directly or indirectly results from or arises out of, normal wear and tear of such Product (including, without limitation, things such as worn seals, diaphragms, balls, O rings, gaskets, chisels, cutters, hoses and other such wearing components; (xi) the issue with a Product is directly or indirectly.

Model Number : SP Series

M. Yadav, Q.A. Manager
(Company Seal)

This page is intentionally
Left blank.