



Operation & Maintenance Guide

Air Motor

**Unidirectional
1VM Series**

**Reversible
1VM Series, 2VM Series, 4VM Series, 6VM Series,
8VM Series, and 16VM Series**

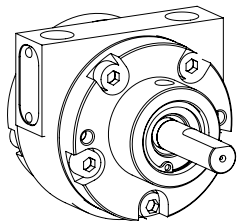

1VM

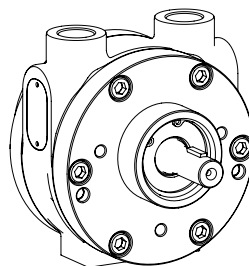

2VM

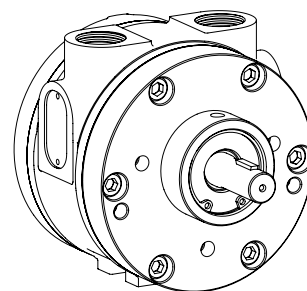

4VM

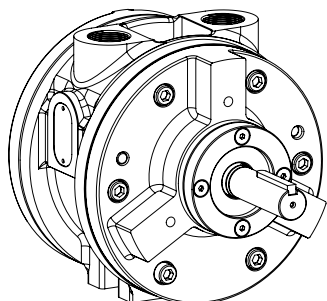

6VM

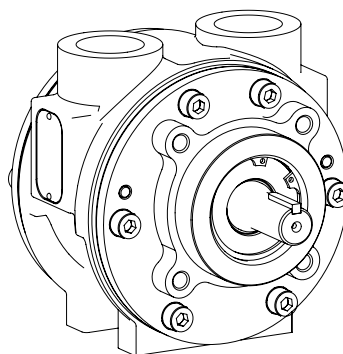

8VM

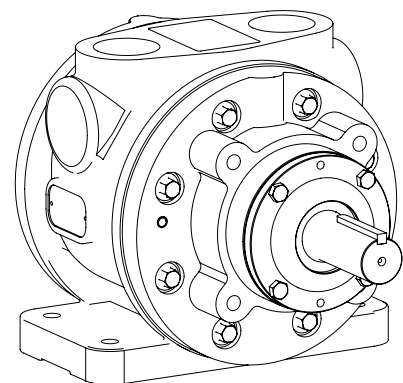

16VM

Table of Contents

3	Safety Instructions
4	Installation Instructions & Operating instructions
5	Suggested Lubricants & Troubleshooting
6	Nomenclature & Specifications
6 / 8	Air Motor Graphs
9	Unidirectional - 1VM Air Motor Dis assembly and Re-assembly
10	Unidirectional, 1VM Series, Air Motor - Exploded View
11	1VM-Clockwise Series, Air Motor - Parts List & Repair Kits for 1VM
12	1VM-Anti-Clockwise Series, Air Motor - Parts List & Repair Kits for 1VM
13	Reversible - 1VM Air Motor Dis assembly and Re-assembly
14	1VM Series, Air Motor - Exploded View
15	1VM Series, Air Motor - Parts List & Repair Kits for 1VM
16 / 17	Dimension Drawings Model - 1VMN Series
18	Reversible - 2VM Air Motor Dis assembly and Re-assembly
19	Reversible - 2VM Series, Air Motor - Exploded View
20	Reversible - 2VM Series, Air Motor - Parts List & Repair Kits for 2VM
21 / 22	Dimension Drawings 2VMD Series
23	Reversible - 4VM Air Motor Dis assembly and Re-assembly
24	Reversible - 4VM Series, Air Motor - Exploded View
25	Reversible - 4VM Series, Air Motor - Parts List & Repair Kits for 4VM
26 / 27	Dimension Drawings 4VMD Series
28	Reversible - 6VM Air Motor Dis assembly and Re-assembly
29	Reversible - 6VM Series, Air Motor - Exploded View
30	Reversible - 6VM Series, Air Motor - Parts List & Repair Kits for 6VM
31 / 32	Dimension Drawings 6VMD Series
33	Reversible - 8VM Air Motor Dis assembly and Re-assembly
34	Reversible - 8VM Series, Air Motor - Exploded View
35	Reversible - 8VM Series, Air Motor - Parts List & Repair Kits for 8VM
36 / 37	Dimension Drawings 8VMD Series
38	Reversible - 16VM Air Motor Dis assembly and Re-assembly
39	Reversible - 16VM Series, Air Motor - Exploded View
40	Reversible - 16VM Series, Air Motor - Parts List & Repair Kits for 16VM
41 / 42	Dimension Drawings 16VML Series
43 / 44	Conditions for use in ATEX Atmosphere
45	Explanation of ATEX and Declaration of Incorporation
46	Eu Declaration of Conformity
47	Warranty Certificate

Intended And Prohibitive Use Intended Use

Versatile for various industrial applications, operating efficiently wherever compressed air is available.

The design of this pneumatic vane motor is confirming to EN/ ISO 80079-36 and 80079-37 explosive atmosphere suitable to use in zone 1 & 2 area, gas group IIC and Dust group IIIC, temp. Class T6 (85°C).

i. EN / ISO 80079-36 : 2016 : Explosive atmospheres—Part 36 :Non-electrical equipment for explosive atmospheres—Basic method and requirements

ii. EN / ISO 80079-37 : 2016 : Explosive atmospheres—Part 37 : Non-electrical equipment for explosive atmospheres—Non-electrical type of protection constructional safety 'c', control of ignition sources 'b', liquid immersion 'k'.

To ensure optimal performance, avoid direct drive and use a flexible coupling with the Air Motor.
Use a bearing housing arrangement for long shafts

Use with non-genuine spare parts or accessories is prohibited

Safety Instructions

Following symbols are used through out this manual.

Warning: If not followed could cause personal injuries

Caution: If not followed could result in damage to equipment.

⚠ WARNING

This manual must be read and the operating instructions carefully followed.

⚠ WARNING

Safety and protective clothing, eyewear, headgear, ear protection, gloves and footwear to be worn during operation of this Vane motor.

⚠ CAUTION

Install proper guard around the output shaft as needed.

⚠ CAUTION

Operators under 18 not allowed to operate this Vane motor operators must be made familiar with the instructions in this manual before attempting to operate the Vane motor Ensure that job site is clear of bystanders. Do Not dis-assemble in explosive atmosphere.

⚠ CAUTION

Use only genuine Teryair or Teryair approved accessories.

⚠ WARNING

This Vane motor is designed for use in an explosive environment for Zone 1 & 2 for Gas and Dust.

⚠ WARNING

Operate the motor for approximately 2 hours at the maximum desired load. Measure the surface temperature of the motor on the casting opposite the pipe ports. The maximum surface temperature listed on the motor is for normal environmental and installation conditions. For air motors Temp. Class T6 (Gas) and T85° C (Dust). The maximum surface temperature should not exceed 80° C. Do not continue to operate the motor if the measured surface temperature exceeds temperature listed on the motor. If your measured temperature does exceed listed value, consult with your Distributor / Representative for a recommendation.

⚠ CAUTION

Completely turn off the Vane motor and disconnect air supply line before attempting any service. Read Assembly and Dis-assembly instructions.

⚠ WARNING

Do not use a hammer on the shaft or connections.
Do Not dis-assemble in explosive atmosphere.

⚠ WARNING

Take care not to exceed the supply air pressure maximum 7kg/cm²(100 psi) for Lubricated and maximum 5.6 kg/cm²(80 psi) for Lube-free

⚠ CAUTION

Do not exert excessive pressure against the work surface. Keep hoses in good condition. Check hoses for signs of wear, cracks & bulges and ensure that they are secure. Accidental disconnection while hose is pressurized makes the hose whip and can be a safety hazard.

⚠ CAUTION

- Please check the hose connection prior to starting motor
- Keep hands & clothing away from moving parts.
- Store these Vane motors in secure & dry environment.
- Do not modify this Vane motor in any way as this will invalidate the warranty and could lead to serious injury.
- Do not drag this Vane motor by air hose

⚠ WARNING

Check the site to make sure that the Vane motor will be adequately ventilated and that there is no external heat input.

Safety wear mandatory while operating Vane motor

Air stream from product may contain solid or liquid particle that can result eye or skin damage. Eye and face and ear protection must be worn at all times during operation Suitable gloves must be worn at all times during operation.

Operators must wear helmets of suitable strength at all times. Helmet must be able to withstand 10G in 8ms without fracturing.

Waterproof heavy duty outerwear and Shoes with toe cap protection are a must during operation.

Ex Code

Model : 1VM Series, 2VM Series,
4VM Series, 6VM Series.

Ⓔ II 2 GD Ex h IIC T6 Gb
Ⓔ II 2 GD Ex h IIIC T85°C Db

Model : 8VM Series, and 16VM Series

Ⓔ II 2GD Ex h IIC T4 Gb
Ⓔ II 2GD Ex h IIIC T135°C Db

Amb. Temp (+1° C to +40° C)

Checklist for installation in hazardous areas

Read air motor label to check that motor has been designed for use in a hazardous application:

- Hazardous zone
- Hazardous category
- Equipment group
- Temperature class
- Maximum surface temperatures

Installation Instructions

An automatic air line lubricator should be installed in the air line as close as possible and no more than 18 inches (1/2 meter) from the air motor. Install the lubricator level with or above the air motor so that the oil mist will blow directly into or fall down into the motor. Install a filter in the air line before the connection to the motor. Next install an air pressure regulator to control motor speed and torque.

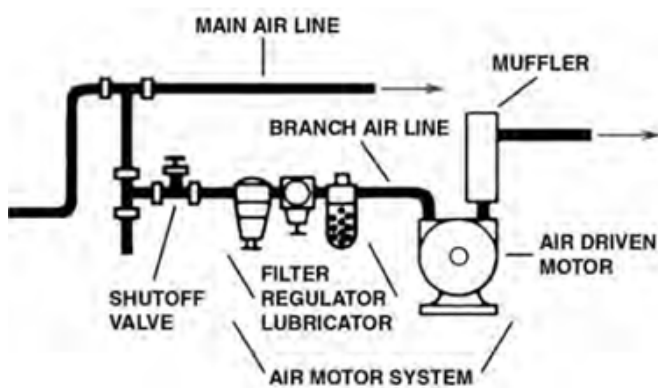

Clean the compressed air connection with low pressure air to remove any dirt from the line before connecting to the ports. Use the proper sized fasteners. For the most efficient output and control of speed, use air lines that are the same size as the motor inlet port if the connection is less than 7 feet (2 meters). For longer connections, use the next pipe size larger than the motor intake port. Connect lines to motor in the proper direction

Operating instructions

Vane motors are rugged dependable product designed to give you years of satisfactory service. Follow the instructions mentioned here to enhance life and performance. Check the direction of the motor airflow. A single rotation motor will operate properly only in one direction. Single rotation motors require a muffler to be connected to the air port. Remove the plastic shipping plugs from the ports. Save plugs for future use during shutdown.

Daily Before Operating

1. Disconnect air line and muffler.
2. Add flushing solvent directly into motor. If using liquid solvent pour in 1 to 2 ounces of recommended oil into the motor.
3. Rotate the shaft by hand in both directions for a few minutes.
4. You must wear eye protection for this step. Cover exhaust with a cloth and reconnect the air line.
5. DO NOT use kerosene or ANY other combustible solvents to flush this product.
6. Restart the motor at a low pressure of approximately 10 PSI/0.7 bar until there is no trace of solvent in the exhaust air.
7. Listen for changes in the sound of the motor. If motor does not sound like it running smoothly, service will be required.

Air Supply

The air should be clean and dry. Supply air pressure maximum 7kg/cm²(100 psi) for Lubricated and maximum 5.6 kg/cm²(80 psi) for Lube-free.

Hoses

- Daily before operation check the hoses, especially the high pressure hoses for damage or leaks
- Use genuine Teryair spares and if possible mention the serial number of the Vane motor when ordering spares.

Mounting

This product can be installed in any orientation. Mount the motor to a solid metal base plate that is mounted to a stable, rigid operating surface. Use shock mounts to reduce noise and vibration. Install a pressure regulator or simple shut-off valve to control motor.

Storage

- It is your responsibility to follow proper shutdown procedures before storage.
- Turn off air intake supply.
- Disconnect air supply and vent all air lines.
- Remove Vane motor from connecting machinery.
- Remove the muffler.
- Wear eye protection. Keep away from air stream. Use clean, dry air to remove condensation from the inlet port of the motor.

Suggested Lubricants

Brand	Above 27 Deg C	From 5 Deg C to 27 Deg C	Below 5 Deg C
Shell	Toona R 72	Toona R 41	Toona R 27
Mobil	Almo 529	Almo 527	Almo 525
Esso	--	Arox EP.65	Arox EP.45
Caltex	Rando Oil 100	Rando Oil 100	Rando Oil 46
Texaco	--	--	Airolene Tool Oil
Daltron	Regal Oil F (R&O)	Regal Oil PE(P&E)	Regal Oil PE(R&O)
Burmah Castrol	Silkolene 881	Silkolene 548/T	Silkolene 733
BP	Castrol RD Oil 3	Castrol RD Oil Light	Megna SPX
Duckham	Garnet 7	Garnet 6	Zero Fio 5
Sternol	Merlin 87	Merlin 71	Merlin 54

- Lubricate motor with a small amount of oil into the intake port. Rotate shaft by hand several times to distribute oil.
- Plug or cap each port.
- Coat output shaft with oil or grease.
- Store motor in a dry environment.

Lubrication Requirements

Lubricated Vane motor: Always install a line lubricator on the air line as close to the Vane motor as possible. A Filter Regulator Lubricator unit (FRL) is strongly recommended. Keep the lubricator bowl topped up with recommended grade of oil and check that the oil is reaching the Vane motor. Running the Lubricated Vane motor without lubrication is likely to cause damage to the components causing premature replacement.

Lub-free Vane motor: Teryair series Vanes are made of a special material that does not require lubrication. While we suggest lube for optimum service life, our Vanes have been shown to last substantially longer than standard laminate versions. This makes Teryair Motors a good choice for food grade or clean room environments where oil is not permitted.

Troubleshooting

Low Torque	Low Speed	Won't run	Runs well but slows down	Reason & Remedy for problem
√	√	√		Dirt or foreign material present. Inspect and flush.
√	√	√		Internal rust. Inspect and flush.
√	√			Low air pressure. Increase pressure.
	√			Air line too small. Install larger line(s).
	√		√	Restricted exhaust. Inspect and repair.
√	√	√	√	Motor is jammed. Have motor serviced.
	√		√	Air source inadequate. Inspect and repair.
	√		√	Air source too far from motor. Reconfigure setup.

Nomenclature

X	X	X	X	X	X	X	X	X
Size	Motor Type	Mounting	Lubricated or Lube-Free	Material of Construction	Explosion Proof	Threading on Inlet and Outlet	Direction of Rotation	No of Vanes
1	VM- Vane Type	L- Face Type	A- Lubricated	L - SG Iron	EX	R- NPT	C - Clockwise	4
2		S- Foot Type		S - SS		G - BSPT		
4		T - Hub		A - Aluminum		P - BSPP	R - Reversible	
6		D - IEC Flange Type						
8		N - NEMA Flange Type						
16								

For example

4VMLALEXRR4 is a size 4, Vane type, Face Mounted, Lubricated, SG Iron MOC. Explosion Proof, NPT Threading, Reversible with 4 Vanes, 4VMTALEXRR8 is a Size 4, Vane type, Hub Mounted, Lubricated, SG Iron MOC, Explosion Proof, NPT Threading, Reversible with 8 Vanes, 1VMTALEXRA4 is a Size 1, Vane type, Hub Mounted, Lubricated, SG Iron MOC, Explosion Proof, NPT Threading, Anticlockwise with 4 Vanes

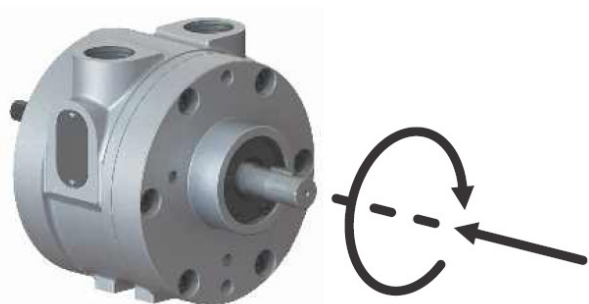

Clockwise

Clockwise nomenclature is clockwise when seen from front of motor

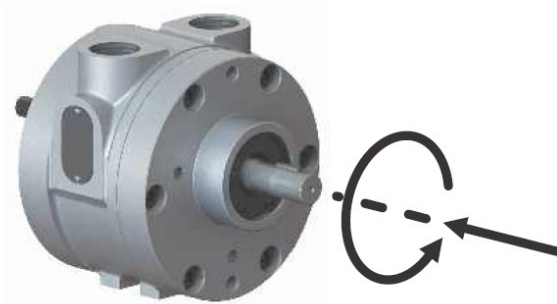

Anti-Clockwise

Anti Clockwise nomenclature is anti clockwise when seen from front of motor

Specifications

Series	Max. Power hp	Speed at Max. Power Free Speed*		Starting Torque		Stall Torque		Air Consumption at Max. Power		Weight		
		kW	rpm	rpm	ft.-lb.	Nm	ft.-lb.	Nm	scfm	m3/m	lb.	kg
1VM	0.45	0.30	7,000	14,000	0.29	0.39	0.38	0.52	25	0.8	2.20	1.00
2VM	0.90	0.67	4,000	8,000	1.70	2.30	2.30	3.10	48	14.0	6.77	3.07
4VM	1.50	1.10	3,000	7,900	2.60	3.50	4.10	5.60	67	1.9	8.16	3.70
											11.22	5.09
6VM	3.60	2.70	3,000	7,900	5.30	7.20	8.70	11.80	120	3.4	16.31	7.40
8VM	4.80	3.60	2,500	7,000	10.00	13.60	14.00	19.00	152	4.3	22.49	10.20
											28.66	13.00
16VM	9.50	7.10	2,000	2,500	40.00	55.00	475.00	65.00	175	4.8	79.60	36.10

* ALL models must be operated with sufficient load to prevent speed from exceeding maximum allowable speed shown on performance curve. Performance figures are at 90 psig (620 kPa) air pressure, with muffler installed.

Air Motor Graphs

Power and Torque Graphs 1VM - UD

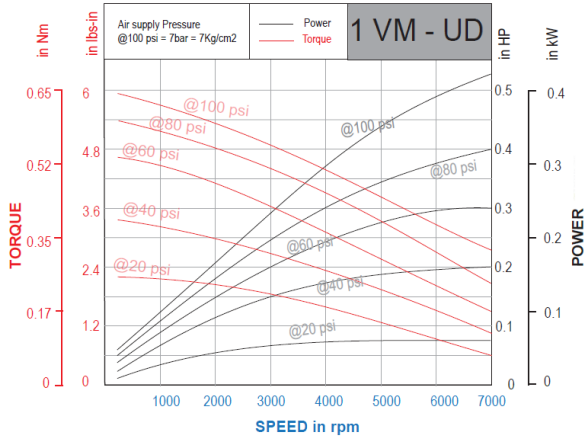

Air Consumption Graph 1VM - UD

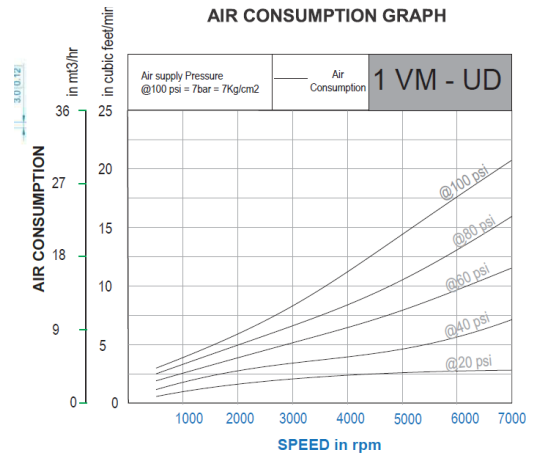

Power and Torque Graphs 1VM

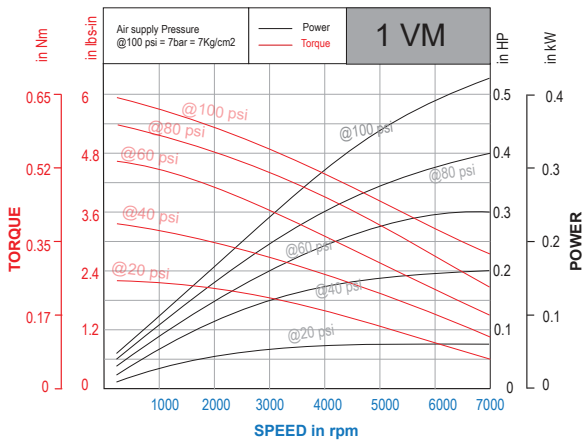

Air Consumption Graph 1VM

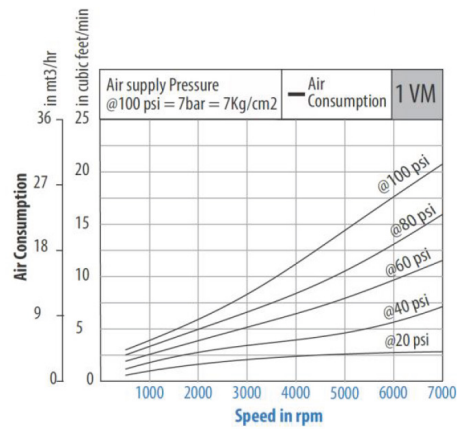

Power and Torque Graphs 2VM

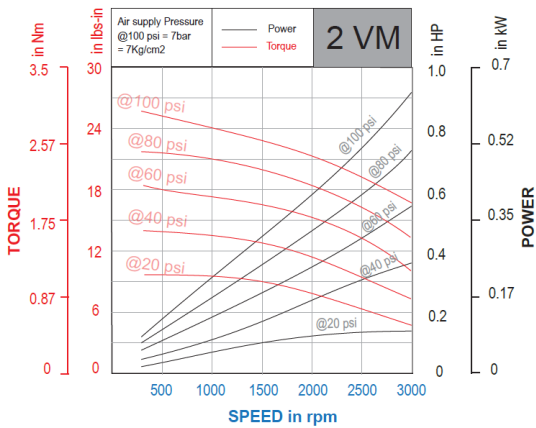

Air Consumption Graph 2VM

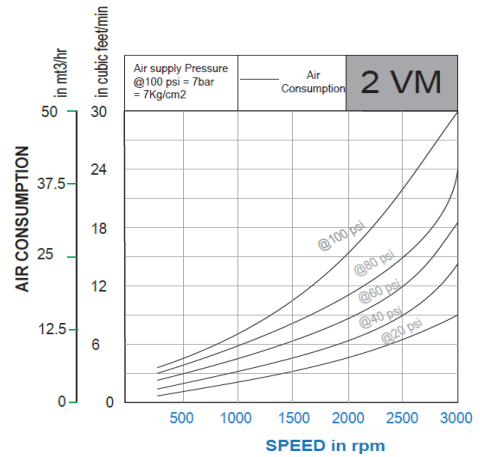

Power and Torque Graphs 4VM

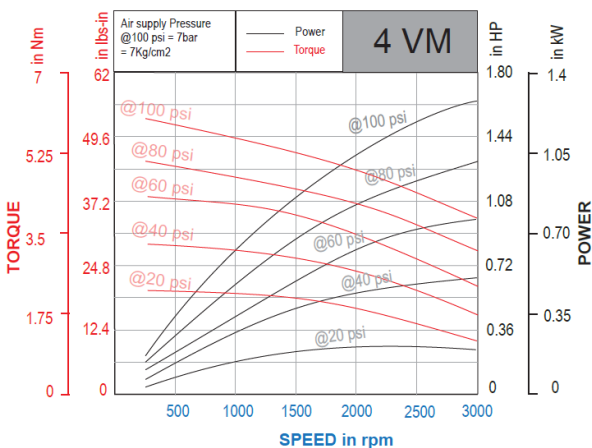

Air Consumption Graph 4VM

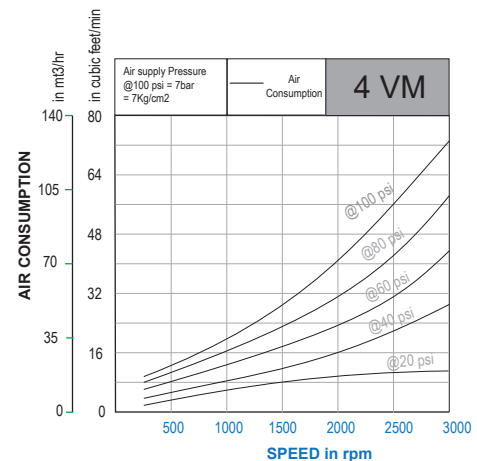

Power and Torque Graphs 6VM

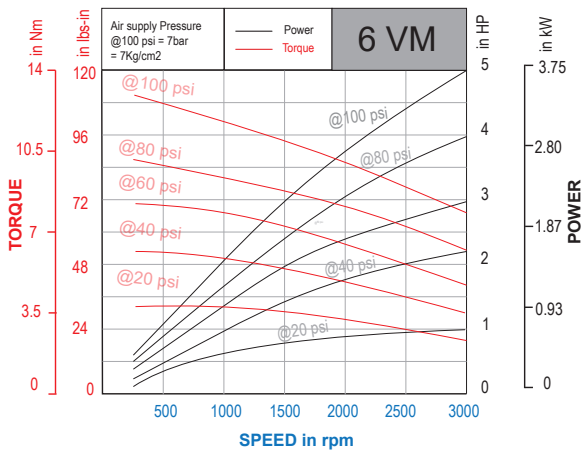

Air Consumption Graph 6VM

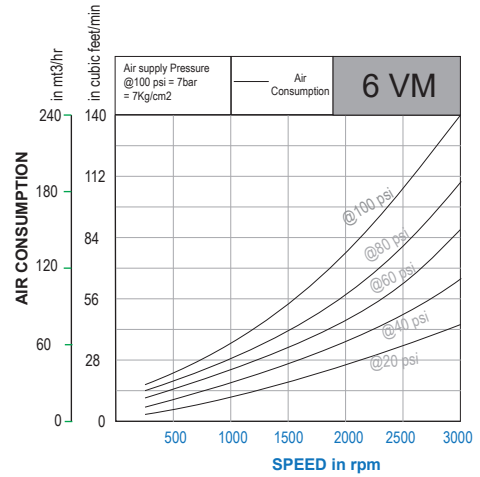

Power and Torque Graphs 8VM

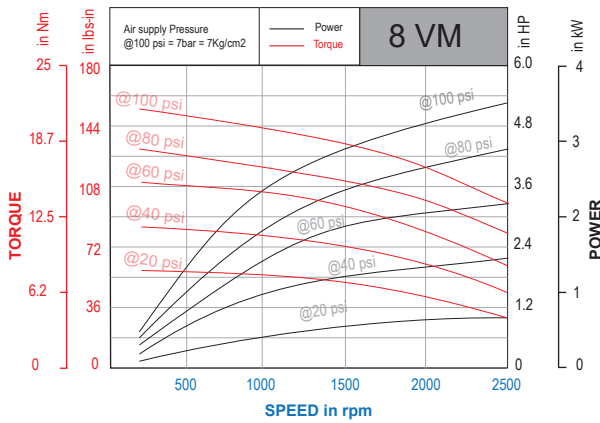

Air Consumption Graph 8VM

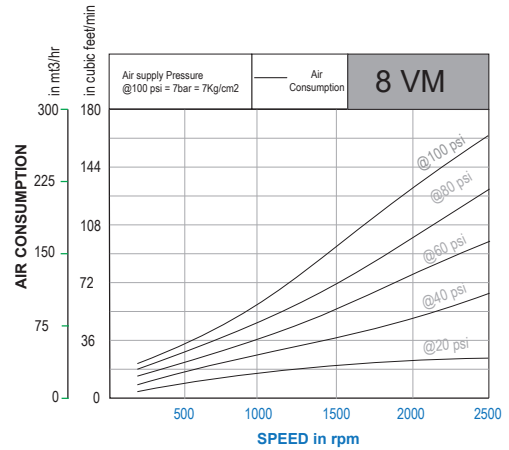

Power and Torque Graphs 16VM

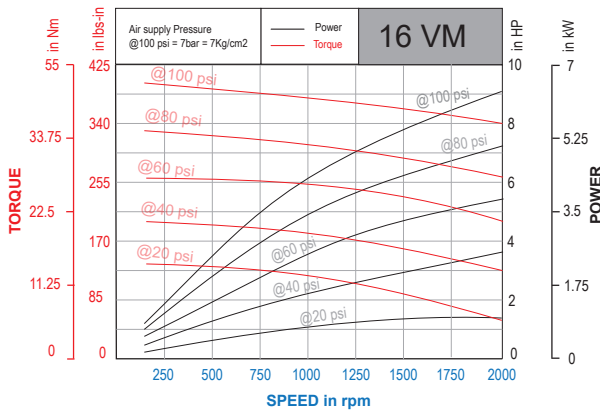

Air Consumption Graph 16VM

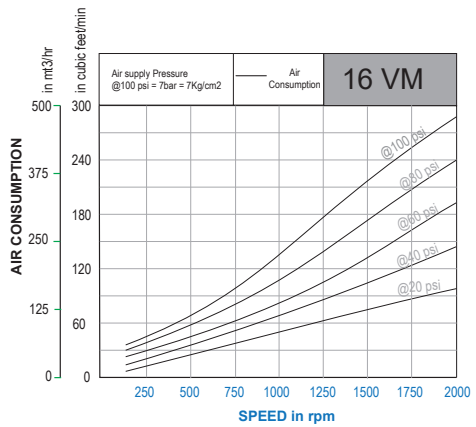

Unidirectional - IVM Air Motor

Dis assembly and Re-assembly

Disconnect air supply and vent all air lines. Air stream from product may contain solid or liquid material that can result in eye or skin damage.

Flush this product in a well ventilated area.

Do not use kerosene or other combustible solvents to flush this product.

Failure to follow these instructions can result in eye injury or other serious injury.

Always open from the back side first. Use proper tools to open the fasteners.

- a. Remove the Silencer (20) and Clean.
- b. For Foot mount motor: Unscrew allen bolt (17) with Spring washer (18) & Plain washer (19) and remove the Foot mounting bracket (16).
- c. Unscrew threaded Bearing Cap (5) from Rear Flange (3) to remove O-ring (8) from bearing Cap and replace with new one (if found damaged).
- d. Unscrew Allen Bolt (15) from Rear Flange (3). Now Tap carefully to Rotor shaft front end by using mallet to remove Rear flange (3) along with Rotor shaft (4).
- e. Now Separate the Rotor shaft (4) from Rear flange (3) carefully by using suitable pin & mallet.
- f. Now replace Shim (6) and also Rotor blades (7) from Rotor shaft (4) with new one (if found damaged).
- g. Now remove Bearing (9) from Rear flange (3) using Suitable pin & mallet and replace with new one (if found damaged/ Rubbing).
- h. Unscrew Allen Bolt (15) from Front Flange (2), now to Separate the Front flange (2) from the Housing (1), place a piece of aluminum on the face of flange from other side of the Housing and carefully hit it with a mallet.
- i. Replace Shim (6) with new one (if found worn out).
- j. Now remove Internal Circlip (12) from Front flange (2) by using circlip plier. Now Remove Bearing (10) and Oil seal (11) from Front flange (2) using suitable pin & mallet and replace it with new ones (if found damaged/ Rubbing).
- k. After installation of Bearing (10) in the Front flange (2), Insert the Rotor shaft (4) into the Front flange bearing precisely.
- l. Now locate the above assembly with Shim (6) on the dowels of the housing (ensure that holes of Housing, Flange & Shim are aligning together). Now tighten them with Allen bolt (15). Ensure that Rotor face is not above the housing face.
- m. Now place the Rotor blades (7) inside the groove of Rotor shaft such that tapers on Rotor blades are facing towards Rotor as shown in the exploded view.
- n. Now insert the Bearing (9) into the rear Flange (3).
- o. Now place the above Flange assembly with Shim (6) on the Housing. (Ensure that holes of Housing, Flange & Shim are aligning together). Now tighten them with Allen bolt (15).
- p. Now after assembly, ensure that Rotor Shaft is rotating smoothly inside else tap lightly by mallet on the rotor shaft front end or rear end until you obtain smooth rotation of rotor shaft.
- q. Once smooth rotation is achieved then insert the Oil seal (11) and Internal Circlip (12) into the Front flange.
- r. Now follow the step 'c', 'b' and 'a' in reverse manner to complete the assembly.

Unidirectional, 1VM Series, Air Motor - Exploded View

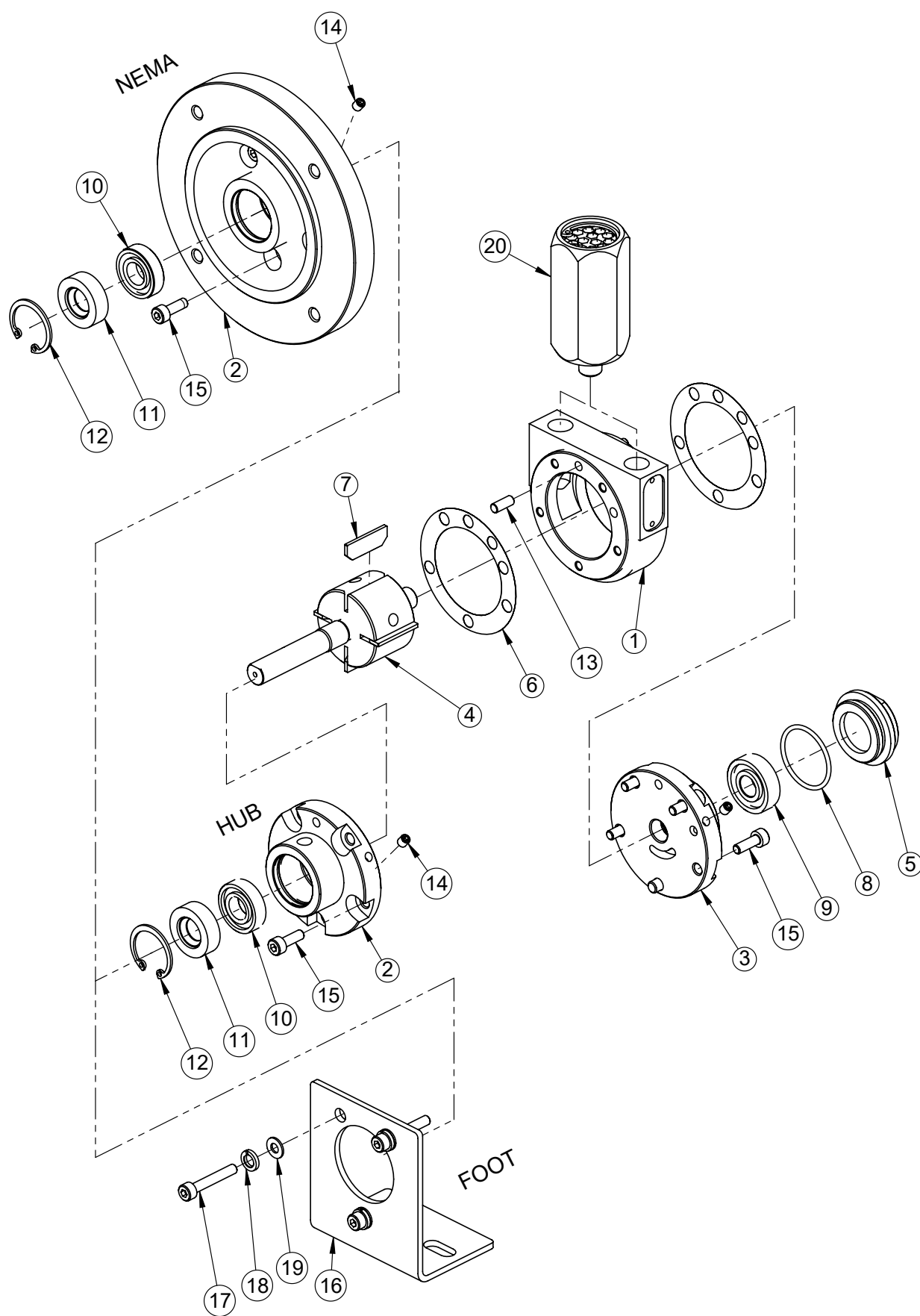

Unidirectional 1VM Clockwise Air Motor - Parts List

Illu. No.	Part Number	Description	Hub	Foot	Nema
1*	8110508	Housing-NPT	1	1	1
1**	8110509	Housing-BSPT	1	1	1
2	8110511	Front Flange-Face/Foot	1	1	-
2	8110512	Nema Flange	-	-	1
3	8110513	Rear Flange	1	1	1
4	8112109	Rotor Shaft-Face/Foot	1	1	-
4	8112110	Rotor Shaft-Nema	-	-	1
5	8112108	Bearing Cap	1	1	1
6	8113702	Shim	4	4	4
7	8113902	Rotor Blade	4	4	4
8	8114001	O Ring	1	1	1
9	8115001	Ball Bearing	1	1	1
10	8115002	Ball Bearing	1	1	1
11	8116001	Oil Seal	1	1	1
12	5009043	Int. Circlip	1	1	1
13	8119001	Dowel Pin	2	2	2
14	8119007	Grub Screw	2	2	2
15	8119005	Allen Bolt	10	7	10
16	8113101	Foot	-	1	-
17	5509056	Allen Bolt	-	3	-
18	8059001	Spring Washer	-	3	-
19	1950824	Plain Washer	-	3	-
20*	8119801	Silencer-NPT	1	1	1
20**	8119802	Silencer-BSPT	1	1	1

Note -

- 1) " * " Marks part are applicable for NPT Models Only
- 2) " ** " Marks part are applicable for BSPT Models Only.

Repair Kits for 1VM

Repair KIT Ordering No	Suitable for
811 97 02	Suitable for 1 VM all variants

Note - Repair Kit includes Blades, Bearings, Shims, Oil Seals and O rings

Unidirectional 1VM Anti-Clockwise Air Motor - Parts List

Illu. No.	Part Number	Description	Hub	Foot	Nema
1*	8110508	Housing-NPT	1	1	1
1**	8110509	Housing-BSPT	1	1	1
2	8110510	Front Flange	1	1	-
2	8110506	Nema Flange	-	-	1
3	8110507	Rear Flange	1	1	1
4	8112112	Rotor Shaft	1	1	-
4	8112106	Rotor Shaft	-	-	1
5	8112108	Bearing Cap	1	1	1
6	8113702	Shim	4	4	4
7	8113902	Rotor Blade	4	4	4
8	8114001	O Ring	1	1	1
9	8115001	Ball Bearing	1	1	1
10	8115002	Ball Bearing	1	1	1
11	8116001	Oil Seal	1	1	1
12	5009043	Int. Circlip	1	1	1
13	8119001	Dowel Pin	2	2	2
14	8119007	Grub Screw	2	2	2
15	8119005	Allen Bolt	10	7	10
16	8113101	Foot	-	1	-
17	5509056	Allen Bolt	-	3	-
18	8059001	Spring Washer	-	3	-
19	1950824	Plain Washer	-	3	-
20*	8119801	Silencer-NPT	1	1	1
20**	8119802	Silencer-BSPT	1	1	1

Note -

- 1) " * " Marks part are applicable for NPT Models Only
- 2) " ** " Marks part are applicable for BSPT Models Only.

Repair Kits for 1VM

Repair KIT Ordering No	Suitable for
811 97 02	Suitable for 1 VM all variants

Note - Repair Kit includes Blades, Bearings, Shims, Oil Seals and O rings

Reversible - 1VM Air Motor

Dis assembly and Re-assembly

Disconnect air supply and vent all air lines. Air stream from product may contain solid or liquid material that can result in eye or skin damage.

Flush this product in a well ventilated area.

Do not use kerosene or other combustible solvents to flush this product.

Failure to follow these instructions can result in eye injury or other serious injury.

Always open from the back side first. Use proper tools to open the fasteners.

- a. Remove the Silencer (19) and clean.
- b. For Foot mount motor: Unscrew allen bolt (16) with Spring washer (17) & Plain washer (18) and remove the Foot mounting bracket (15).
- c. Unscrew Threaded Bearing Cap (5) from Rear Flange (3) to Remove O-ring (8) from bearing Cap and replace with new one (if found damaged).
- d. Unscrew Allen Bolt (13) from Rear Flange (3), Now Tap carefully to Rotor shaft front end by using mallet to remove Rear flange (3) along with Rotor shaft (4).
- e. Now Separate the Rotor shaft (4) from Rear flange (3) carefully by using suitable pin & mallet.
- f. Now replace Shim (6) and also Rotor blades (7) and Ejection rings (14) from Rotor shaft (4) with new ones (if found damaged).
- g. Now remove Bearing (9) from Rear flange (3) using Suitable pin & mallet and replace with new one (if found damaged/ Rubbing).
- h. Unscrew Allen Bolt (13) from Front Flange (2), now to Separate the Front flange (2) from the Housing (1), place a piece of aluminum on the face of flange from other side of the Housing and carefully hit it with a mallet.
- i. Now replace Shim (6) with new one (if found worn out).
- j. Now remove internal circlip (11) from Front flange (2) by using circlip plier. Now Remove Bearing (9) and Oil seal (10) from Front flange (2) using suitable pin & mallet and replace it with new ones (if found damaged/Rubbing)
- k. After installation of Bearing (9) in the Front flange (2), place Ejection ring (14) front side of Rotor shaft (4), now Insert the Rotor shaft into the Front flange bearing precisely.
- l. Now place the ejection ring (14) on other side of Rotor shaft (4), now place Blades (7) inside the groove of the Rotor shaft (4) such that Blades are placed on the Ejection rings outer diameter touching all the blades.
- m. Now locate the above assembly carefully with Shim (6) on the dowels of the housing (ensure that holes of Housing, Flange & Shim are aligning together). Now tighten them with Allen bolt (13). Ensure that Rotor face is not above the housing face
- n. Now insert the Bearing (9) into the Rear flange (3).
- o. Now place the above Flange assembly with Shim (6) on the Housing (1). (Ensure that holes of Housing, Flange & Shim are aligning together). Now tighten them with Allen bolt (13).
- p. Now after assembly, ensure that Rotor Shaft is rotating smoothly inside else tap lightly by mallet on the rotor shaft front end or rear end until you obtain smooth rotation of rotor shaft.
- q. Once smooth rotation is achieved then insert the Oil seal (10) and Internal Circlip (11) into the Front flange.
- r. Now follow the step 'b' and 'a' in reverse manner to complete the assembly.

IVM Series, Air Motor - Exploded View

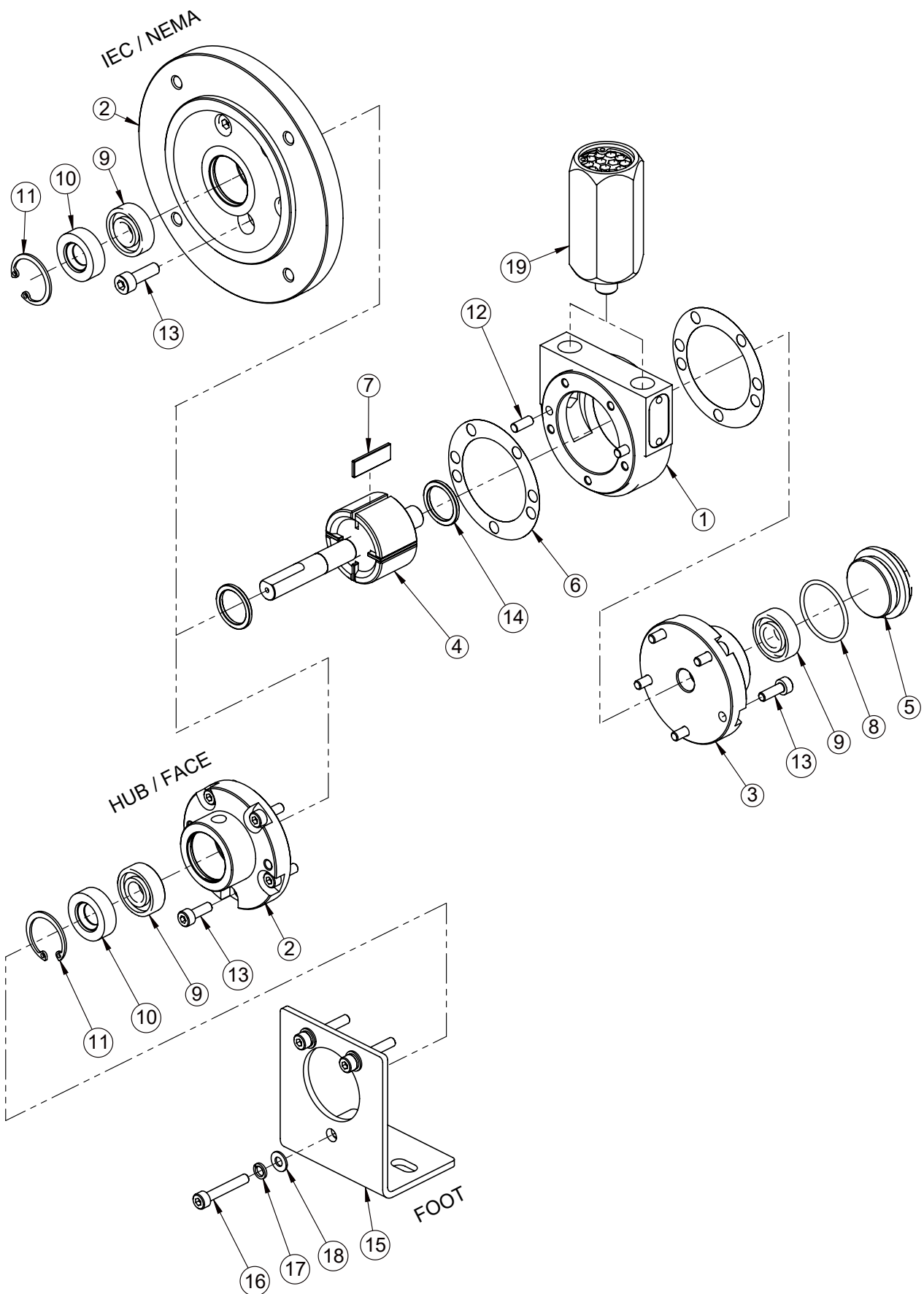

IVM Series, Air Motor - Parts List

Illu. No.	Part Number	Description	Hub	Foot	Nema
1*	8110501	Housing-NPT	1	1	1
1**	8110505	Housing-BSPT	1	1	1
2	8110514	Front Flange-Face/Foot	1	1	-
2	8110504	Nema Flange	-	-	1
3	8110503	Rear Flange	1	1	1
4	8112115	Rotor Shaft- Face/Foot	1	1	-
4	8112103	Rotor Shaft-Nema	-	-	1
5	8112102	Bearing Cap	1	1	1
6	8113701	Shim	4	4	4
7	8113901	Rotor Blade	4	4	4
7	8113901LF	Rotor Blade Lube Free	-	-	-
8	8114001	O Ring	1	1	1
9	8115009	Ball Bearing	2	2	2
10	8116001	Oil Seal	1	1	1
11	5009043	Int. Circlip	1	1	1
12	8119001	Dowel Pin	2	2	2
13	8119005	Allen Bolt	10	7	10
14	8112104	Ejection Ring	2	2	2
15	8033102	Foot	-	1	-
16	8119003	Allen Bolt	-	3	-
17	2980004	Spring Washer	-	3	-
18	1950824	Plain Washer	-	3	-
19*	8119801	Silencer-NPT	1	1	1
19**	8119802	Silencer-BSPT	1	1	1

Note -

- 1) " * " Marks part are applicable for NPT Models Only
- 2) " ** " Marks part are applicable for BSPT Models Only.

Repair Kits for IVM

Repair KIT Ordering No	Suitable for
811 97 02	Suitable for IVM all variants

Note - Repair Kit includes Blades, Bearings, Shims, Ejection rings, Oil Seals and O rings

Dimension Drawings

Model - 1VM-Unidirectional

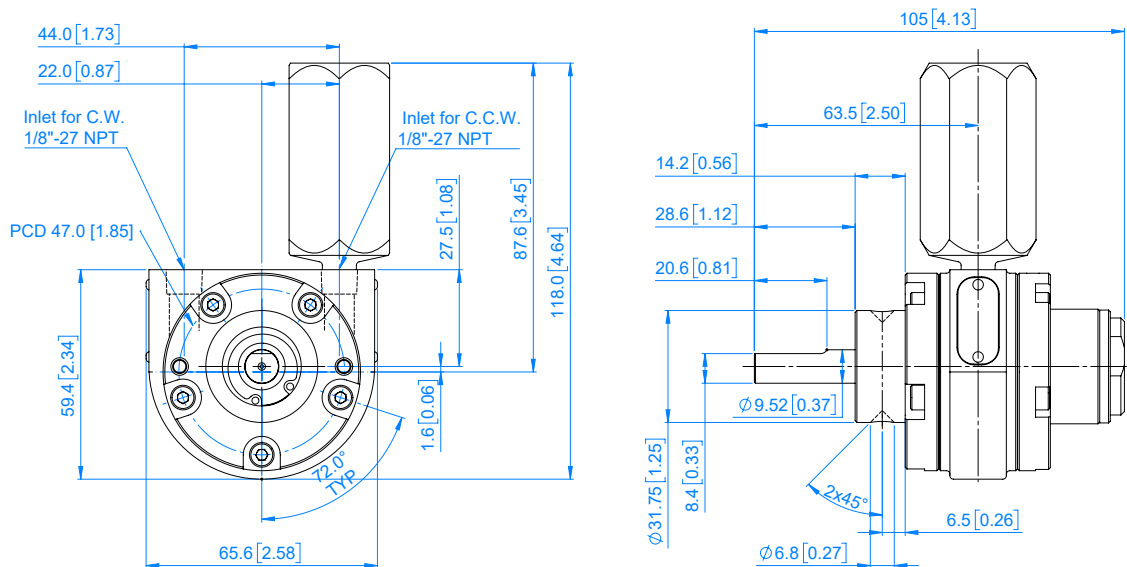

Model - 1VMN (NEMA)

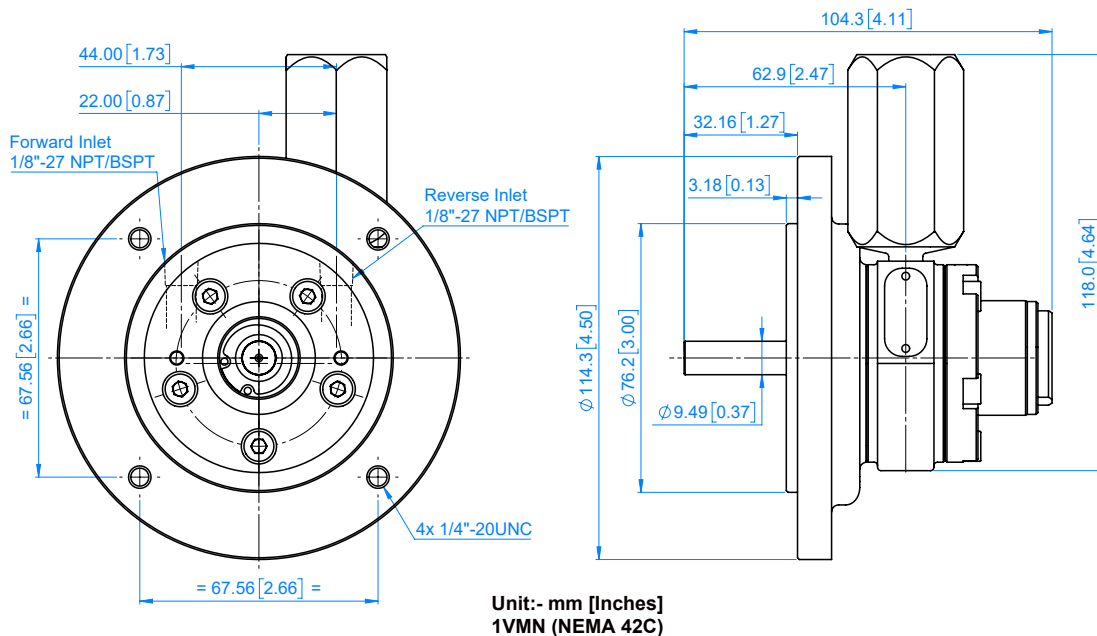

Dimension Drawings

Model - 1VMS (FOOT)

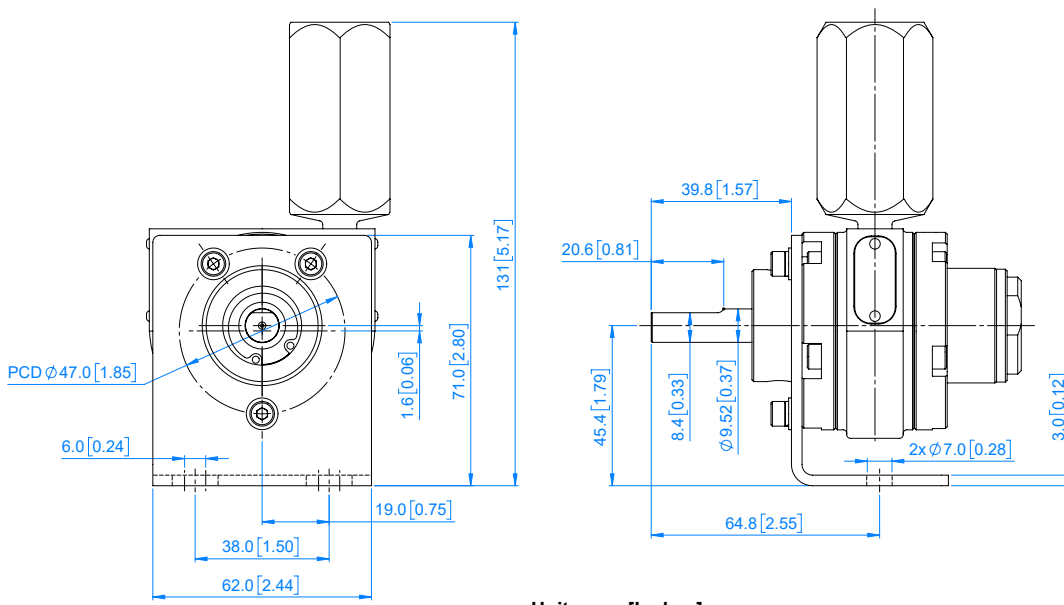

**Unit:- mm [Inches]
1VMS (FOOT)**

Model - 1VMT (HUB)

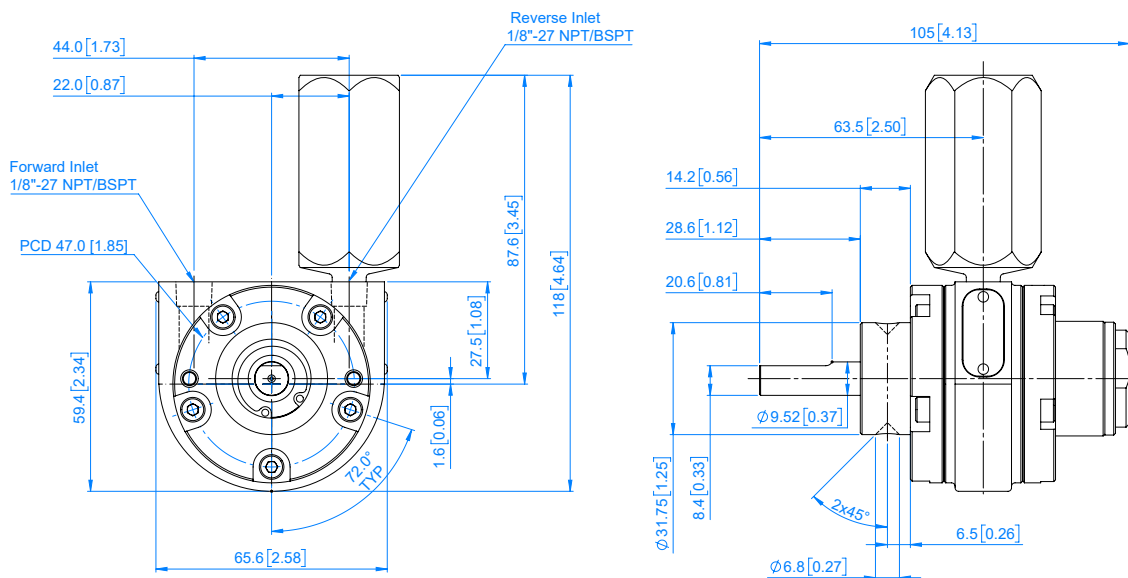

**Unit:- mm [Inches]
1VMT (HUB)**

Reversible - 2VM Air Motor

Dis assembly and Re-assembly

Disconnect air supply and vent all air lines. Air stream from product may contain solid or liquid material that can result in eye or skin damage.

Flush this product in a well ventilated area.

Do Not use kerosene or other combustiblesolvents to flush this product.

Failure to follow these instructions can result in eye injury or other serious injury.

Always open from the back side first.

Use proper tools to open the fasteners.

- a. Remove the Silencer (24) and clean.
- b. For IEC/ Nema motor: Unscrew allen bolt (15) with Spring washer (19) and remove the Flange (2A).
- c. For foot mount motor: Unscrew allen bolt (22) with Spring washer (23) and remove the Foot mounting bracket (21).
- d. Remove the Key (6) from Rotor shaft (4).
- e. Unscrew Allen Bolts (20) with Spring Washer
- f. (18) from Bearing Cap (5) to Remove O-ring (9) from Rear Flange (3) and replace with new one (if found damaged).
- g. Unscrew Allen Bolts (15) with Spring Washer(19) from Rear Flange (3), now Tap carefully to the Rotor shaft front end by using mallet to remove Rear flange (3) along with Rotor shaft (4).
- h. Now Separate the Rotor shaft (4) from Rear flange (3) carefully by using suitable pin & mallet.
- i. Now remove the Shim (7) and also Rotor blades (8), Spring cap (17) and Compression spring (16) from Rotor shaft (4) and replace it with new ones (if found damaged).
- j. Now remove the Bearing (11) from Rear flange (3) using Suitable pin & mallet and replace with new one (if found damaged/ Rubbing).
- k. Unscrew Allen Bolt (15) with Spring washer (19) from Front Flange (2), now to Separate the Front flange (2) from the Housing (1), place a piece of aluminum on the face of flange from other side of the Housing and carefully hit it with a mallet.
- l. Now replace Shim (7) with new one (if found worn out).
- m. Now remove internal circlip (13) by using circlip plier. Now Remove Bearing (10) and Oil seal (12) from Front flange (2) using suitable pin & mallet and replace it with new ones (if found damaged/Rubbing).
- n. After installation of Bearing (10) in the Front flange (2), insert the Rotor shaft (4) into the Front flange bearing precisely.
- o. Now assemble Compression Springs (16) with Spring caps (17) on both end of springs. After that, insert the same into the Rotor shaft's (4) through holes (use small amount of grease to prevent spring caps to fall during assembly). Now place the 4 nos. Rotor Blades (8) into the rotor shaft grooves.
- p. Now hold the blades with your hand while inserting the above assembly into the Housing (1), now locate this assembly with Shim (7) on the dowels of the Housing (ensure that holes of Housing, Flange & Shim are aligning together). Now tighten them with Allen bolt (15) & spring washer (19). Ensure that Rotor face is not above the housing face.
- q. Now insert the Bearing (11) into the Rear flange (3).
- r. Now place the above Flange assembly with Shim (7) on the Housing (1). (Ensure that holes of Housing, Flange & Shim are aligning together). Now tighten them with Allen bolt (15) with Spring washer (19).
- s. Now after assembly, ensure that Rotor Shaft (4) is rotating smoothly inside, else tap lightly on the rotor shaft front end or rear end until you obtain smooth rotation of Rotor Shaft.
- t. Once smooth rotation is achieved then insert the Oil seal (12) and Internal Circlip (13) into the Front flange (2).
- u. Now follow the step 'd, c, b and a' in reverse manner to complete the assembly.

Reversible - 2VM Series, Air Motor - Exploded View

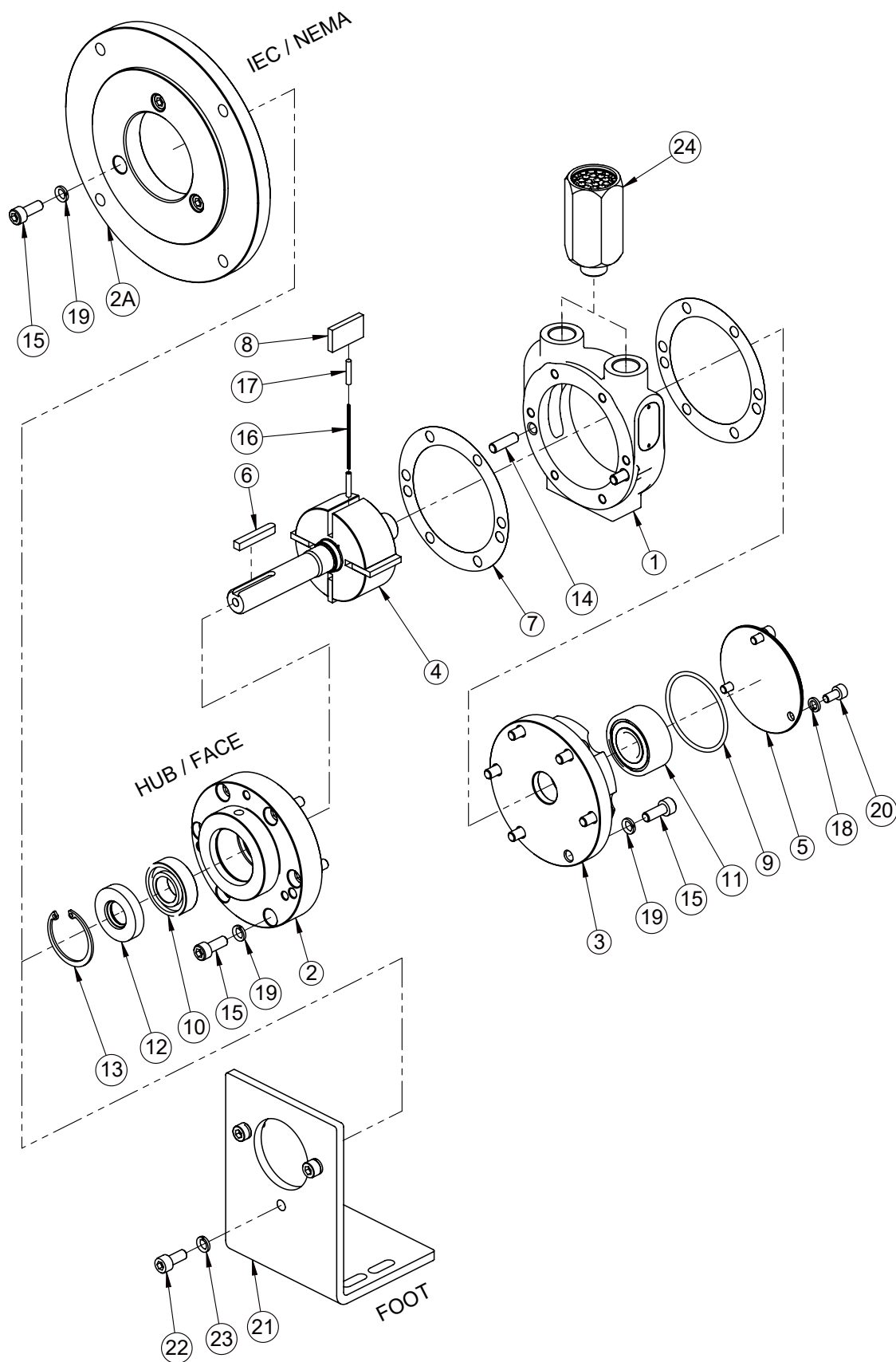

Reversible - 2VM Series, Air Motor - Parts List

Illu. No.	Part Number	Description	Hub	Foot	IEC	Nema
1*	8030501	Housing-NPT	1	1	1	1
1**	8030506	Housing-BSPT	1	1	1	1
2	8030511	Front Flange Face/Foot	1	1	-	-
2	8030509	Front Flange	-	-	1	-
2A	8030512	IEC Flange	-	-	1	-
2	8030508	Front Flange	-	-	-	1
2A	8030510	Nema Flange	-	-	-	1
3	8030503	Rear Flange	1	1	1	1
4	8032101	Rotor Shaft Face/Foot	1	1	-	-
4	8032115	Rotor Shaft IEC	-	-	1	-
4	8032111	Rotor Shaft Nema	-	-	-	1
5	8032102	Bearing Cap	1	1	1	1
6	8032201	Key IEC	-	-	1	-
6	8042203	Key Nema	-	-	-	1
7	8033701	Shim	4	4	4	4
8	8033901	Rotor Blade	4	4	4	4
9	8034001	O Ring	1	1	1	1
10	8035001	Ball Bearing	1	1	1	1
11	1995035	Ball Bearing	1	1	1	1
12	8036001	Oil Seal	1	1	1	1
13	8049002	Int. Circlip	1	1	1	1
14	8049004	Dowel Pin	4	4	4	4
15	8049003	Allen Bolt	12	12	15	15
16	8045103	Compression Spring	2	2	2	2
17	8042103	Bush	4	4	4	4
18	8059001	Spring Washer	3	3	3	3
19	5369004	Spring Washer	12	12	15	15
20	5509028	Allen Bolt	3	3	3	3
21	8033102	Foot	-	1	-	-
22	8049007	Allen Bolt	-	3	-	-
23	5009048	Spring Washer	-	3	-	-
24*	8039803	Silencer-NPT	1	1	1	1
24**	8039804	Silencer-BSPT	1	1	1	1

Note -

- 1) “*” Marks part are applicable for NPT Models Only
- 2) “**” Marks part are applicable for BSPT Models Only.

Repair Kits for 2VM

Repair KIT Ordering No	Suitable for
803 97 01	Suitable for 2VM Hub / Foot / Nema & IEC variant

Note - Repair Kit includes Blades, Bearings, Shims, Oil Seals and O rings

Dimension Drawings

Model - 2VMD (IEC)

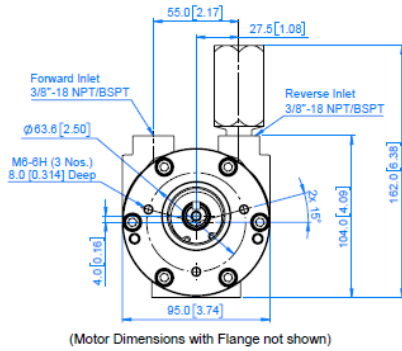
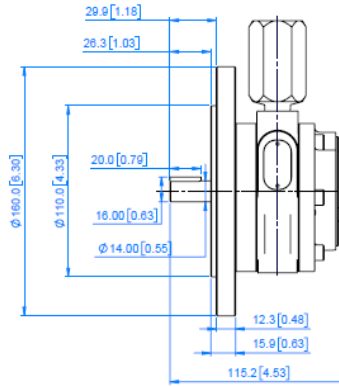
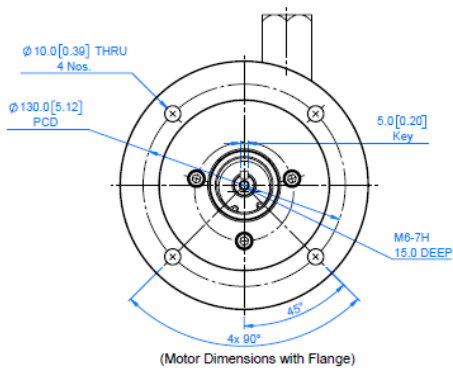

Unit:- mm [Inches]
2VMD (IEC #72, FRAME SIZE D71)

Model - 2VMN (NEMA)

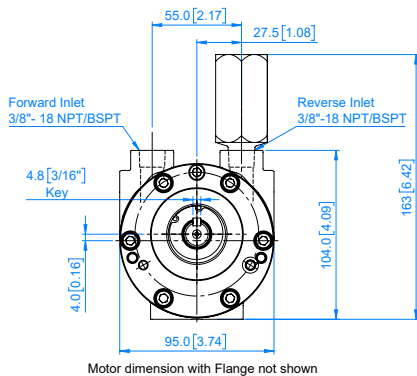
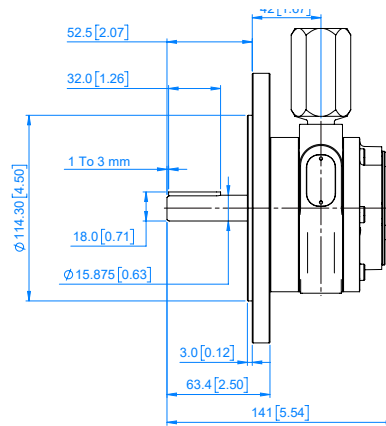
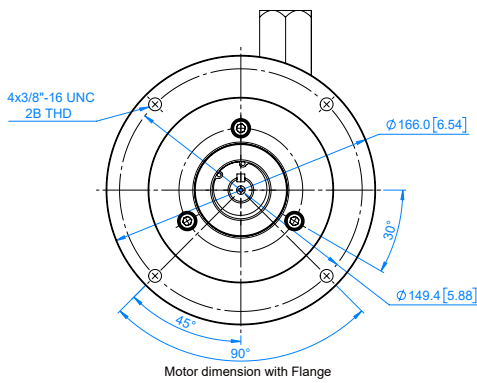

Unit:- mm [Inches]
2VMN (NEMA 56C)

Dimension Drawings

Model - 2VMS (FOOT)

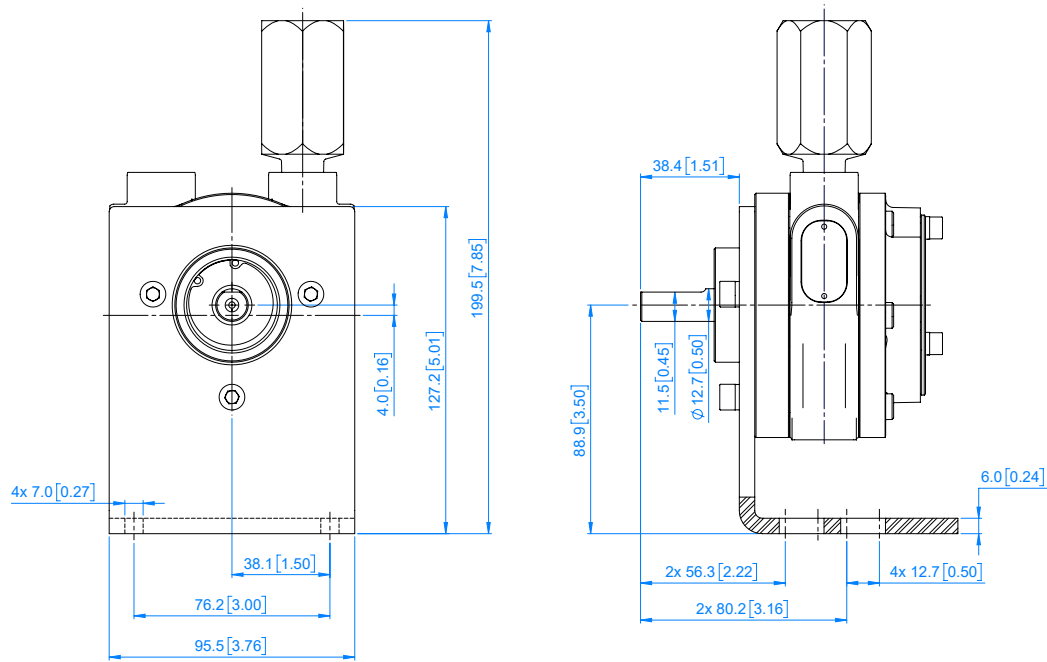

**Unit:- mm [Inches]
2VMS (FOOT)**

Model - 2VMT (HUB)

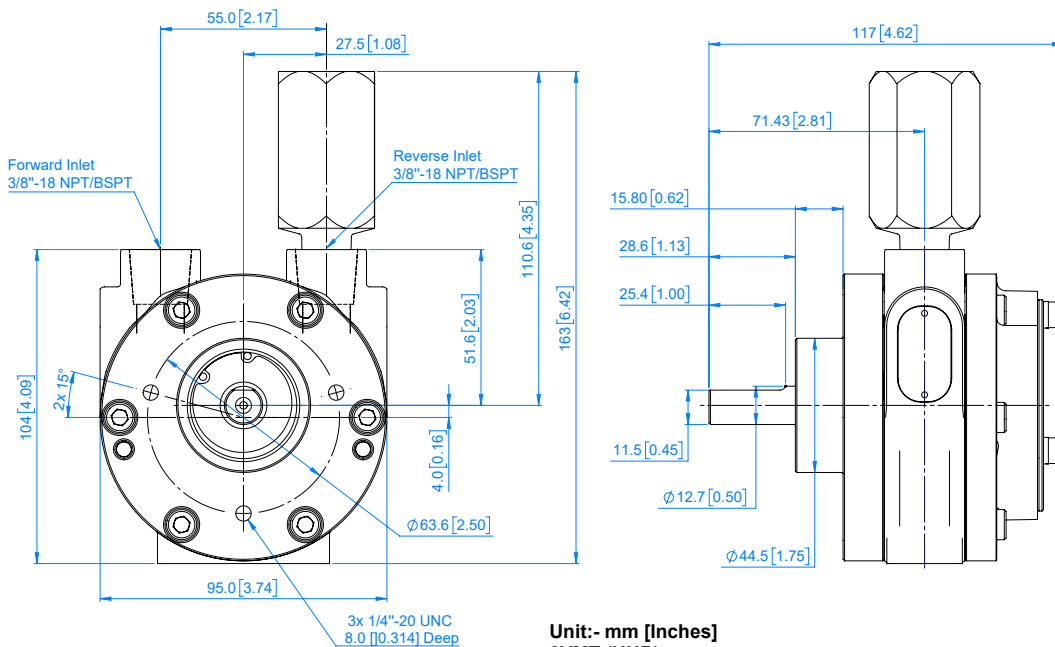

**Unit:- mm [Inches]
2VMT (HUB)**

Reversible - 4VM Air Motor Dis assembly and Re-assembly

Disconnect air supply and vent all air lines. Air stream from product may contain solid or liquid material that can result in eye or skin damage.

Flush this product in a well ventilated area.

Do Not use kerosene or other combustiblesolvents to flush this product.

Failure to follow these instructions can result in eye injury or other serious injury.

Always open from the back side first.

Use proper tools to open the fasteners.

- a. Remove the Silencer (24) and clean.
- b. For IEC/ Nema motor: Unscrew allen bolt (15) with Spring washer (19) and remove the Flange (2A).
- c. For Foot mount motor: Unscrew allen bolt (22) with Spring washer (23) and remove the Foot mounting bracket (21).
- d. To remove Bearing cap (5) from Rear flange (3) Un-screw Allen Bolts (12) with Spring Washer (11) from Bearing Cap (5) then Remove O-ring (8) and replace with new one (if found damaged).
- e. Unscrew Allen Bolts (15) with Spring Washer (19) from Rear Flange (3), now Tap carefully to the Rotor shaft front end by using mallet to remove Rear flange (3) along with Rotor shaft (4).
- f. Now Separate the Rotor shaft (4) from Rear flange (3) carefully by using suitable pin & mallet.
- g. Now remove the Shim (10) and also Rotor blades (16), Spring cap (18) and Compression spring (17) from Rotor shaft (4) and replace it with new ones (if found damaged).
- h. Now remove the Bearing (6) from Rear flange (3) using Suitable pin & mallet and replace with new one (if found damaged/ Rubbing).
- i. Unscrew Allen Bolt (15) with Spring washer (19) from Front Flange (2), now to Separate the Front flange (2) from the Housing (1), place a piece of aluminum on the face of flange from other side of the Housing and carefully hit it with a mallet.
- j. Now replace Shim (10) with new one (if found worn out).
- k. Now remove internal circlip (20) by using circlip plier. Now Remove Bearing (7) and Oil seal (9) from Front flange (2) using suitable pin & mallet and replace it with new ones (if found damaged/Rubbing).
- l. After installation of Bearing (7) in the Front flange (2), insert the Rotor shaft (4) into the Front flange bearing precisely.
- m. Now assemble Compression Springs (17) with Spring caps (18) on both end of springs. After that, insert the same into the Rotor shaft's (4) through holes (use small amount of grease to prevent spring caps to fall during assembly). Now place the 4 nos. Rotor Blades (16) into the rotor shaft grooves.
- n. Now hold the blades with your hand while inserting the above assembly into the Housing (1), now locate this assembly with Shim (7) on the dowels of the Housing (ensure that holes of Housing, Flange & Shim are aligning together). Now tighten them with Allen bolt (15) & spring washer (19). Ensure that Rotor face is not above the housing face.
- o. Now insert the Bearing (6) into the Rear flange (3).
- p. Now place the above Flange assembly with Shim (10) on the Housing (1). (Ensure that holes of Housing, Flange & Shim are aligning together). Now tighten them with Allen bolt (15) with Spring washer (19).
- q. Now after assembly, ensure that Rotor Shaft (4) is rotating smoothly inside, else tap lightly on the rotor shaft front end or rear end until you obtain smooth rotation of Rotor Shaft.
- r. Once smooth rotation is achieved then insert the Oil seal (9) and Internal Circlip (20) into the Front flange (2).
- s. Now follow the step 'd, c, b and a' in reverse manner to complete the assembly.

Reversible - 4VM Series, Air Motor - Exploded View

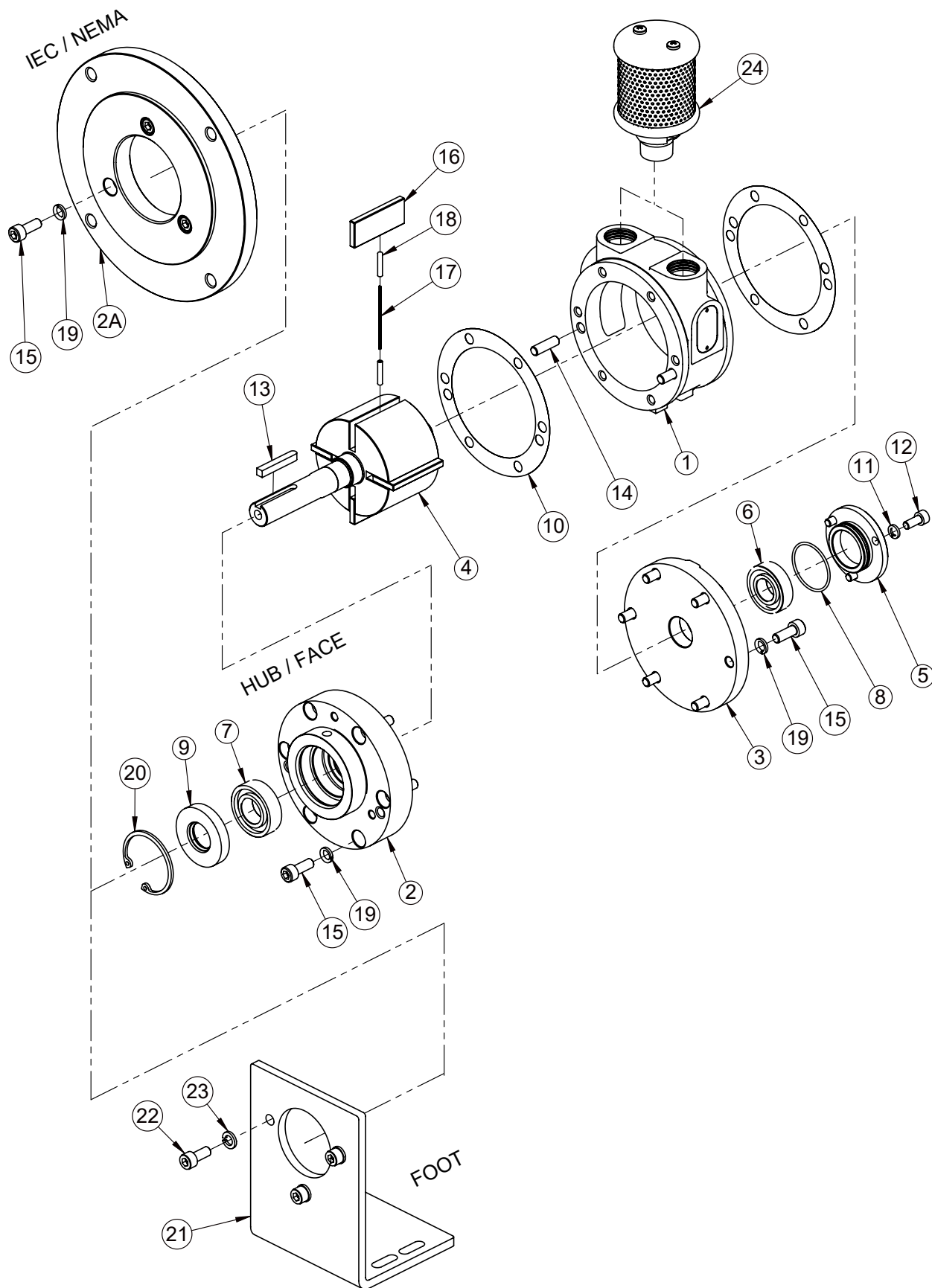

Reversible - 4VM Series, Air Motor - Parts List

Illu. No.	Part Number	Description	Face	Foot	IEC	Nema
1*	8040501	Housing-NPT	1	1	1	1
1**	8040511	Housing-BSPT	1	1	1	1
2	8040504	Front Flange-Face/Foot	1	1	-	-
2	8040502	Front Flange	-	-	1	-
2A	8040518	IEC Flange	-	-	1	-
2	8040515	Front Flange	-	-	-	1
2A	8040517	Nema Flange	-	-	-	1
3	8040503	Rear Flange	1	1	1	1
4	8042108	Rotor Shaft-Face/Foot	1	1	-	-
4	8042115	Rotor Shaft-IEC	-	-	1	-
4	8042116	Rotor Shaft-Nema	-	-	-	1
5	8042102	Bearing Cap	1	1	1	1
6	8045001	Ball Bearing	2	2	2	1
7	8035001	Ball Bearing	-	-	-	1
8	8044001	O Ring	1	1	1	1
9	8046001	Oil Seal	1	1	1	-
9	8046002	Oil Seal	-	-	-	1
10	8043701	Shim	4	4	4	4
11	8059001	Spring Washer	3	3	3	3
12	5509028	Allen Bolt	3	3	3	3
13	8042202	Woodruff Key	1	1	-	-
13	8032201	Key	-	-	1	-
13	8032203	Key	-	-	-	1
14	8049004	Dowel Pin	4	4	4	4
15	8049003	Allen Bolt	12	12	15	15
16	8043901	Rotor Blade	4	4	4	4
17	8045103	Compression Spring	2	2	2	2
18	8042103	Bush	4	4	4	4
19	5369004	Spring Washer	12	12	15	15
20	8049002	Internal Circlip	1	1	1	-
20	2109024	Internal Circlip	-	-	-	1
21	8043102	Foot	-	1	-	-
22	8049007	Allen Bolt	-	3	-	-
23	5009048	Spring Washer	-	3	-	-
24*	8059801	Silencer NPT	1	1	1	1
24**	8059802	Silencer BSPT	1	1	1	1

Note -

- 1) * * * Marks part are applicable for NPT Models Only
- 2) ** * Marks part are applicable for BSPT Models Only.

Repair Kits for 4VM

Repair KIT Ordering No	Suitable for
804 97 01	Suitable for 4VM Hub / Foot / IEC variant
804 97 02	Suitable for Nema variant

Note - Repair Kit includes Blades, Bearings, Shims, Oil Seals and O rings

Dimension Drawings

Model - 4VMD (IEC)

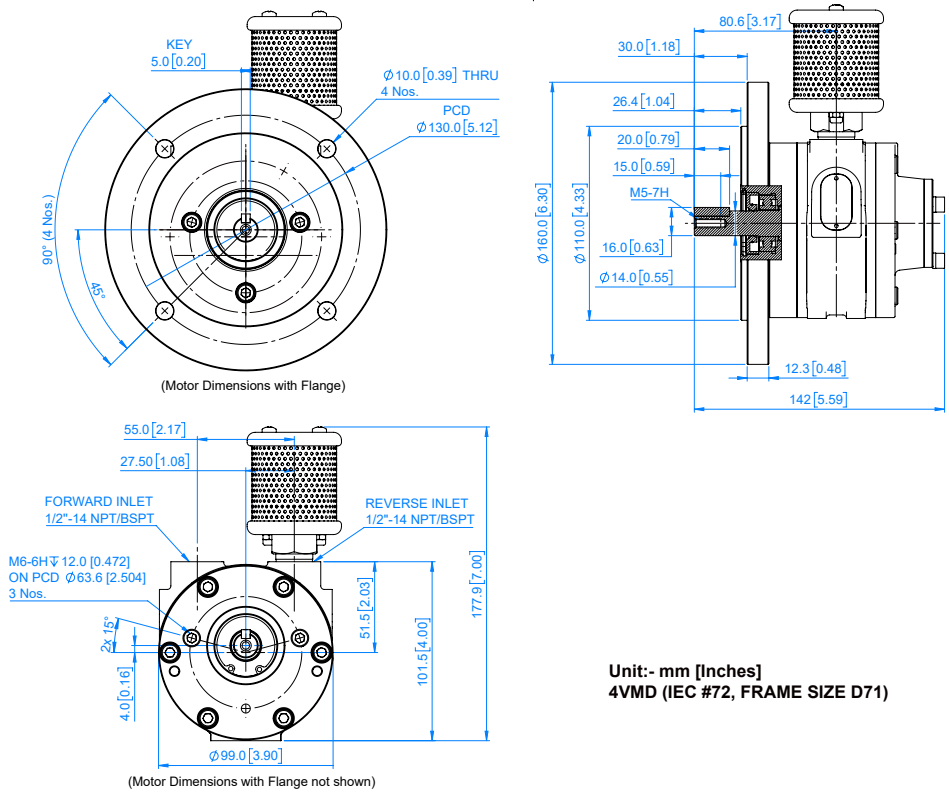

Model - 4VMN (NEMA)

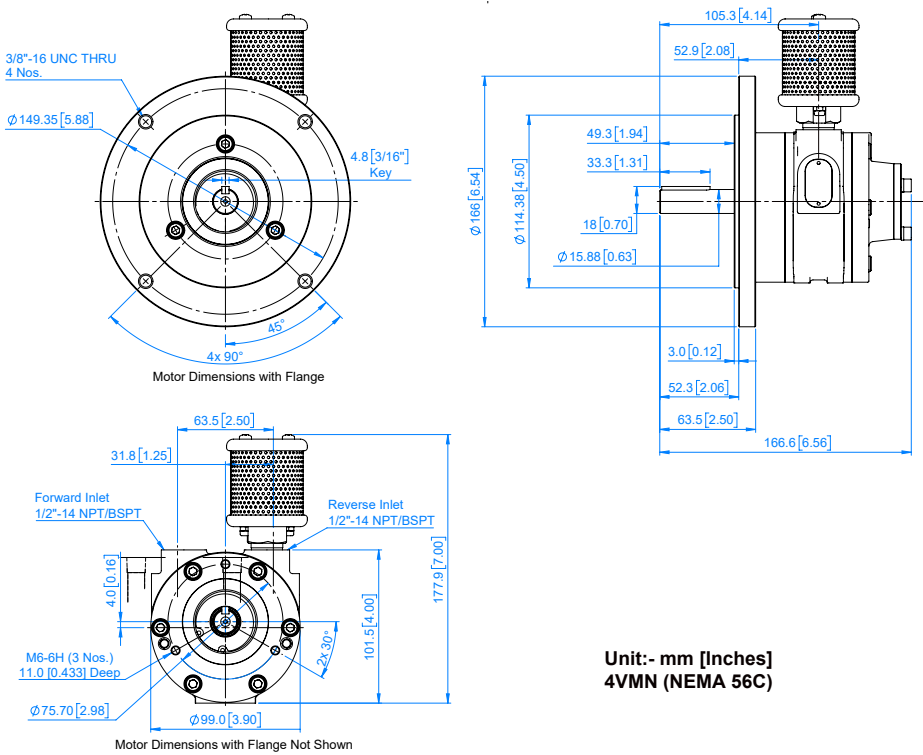

Dimension Drawings

Model - 4VML (FACE)

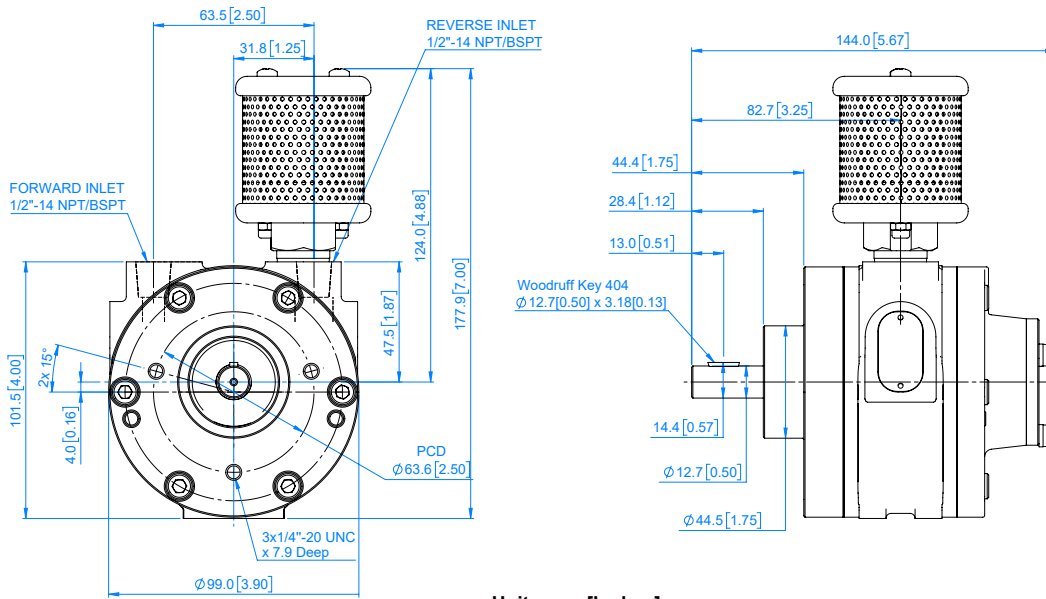

Unit - mm [Inches]
4VML (FACE)

Model - 4VMS (FOOT)

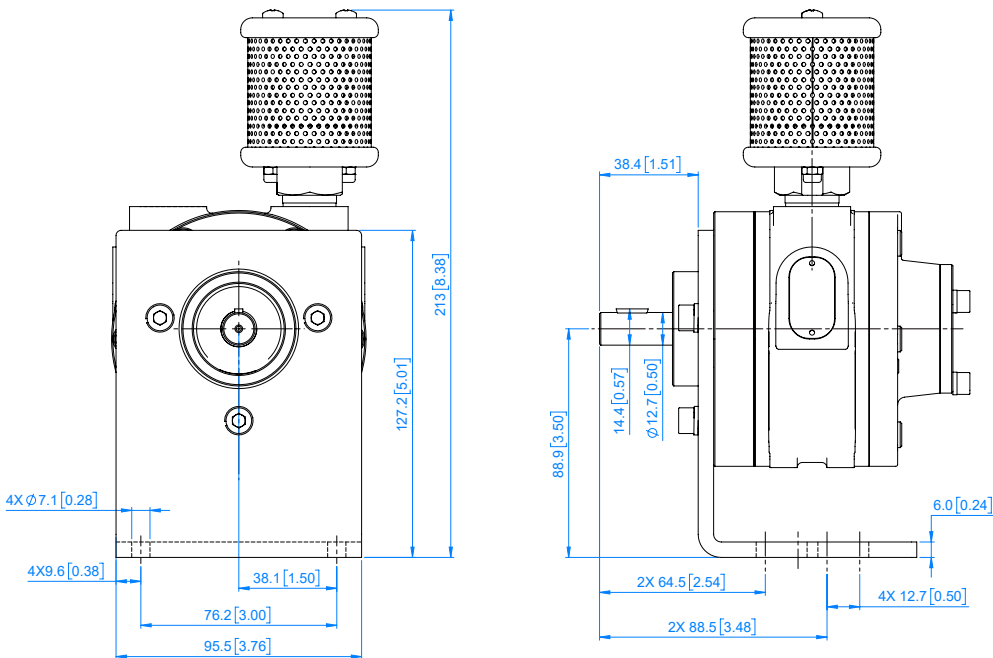

Unit - mm [Inches]
4VMS (FOOT)

Reversible - 6VM Air Motor

Dis assembly and Re-assembly

Disconnect air supply and vent all air lines. Air stream from product may contain solid or liquid material that can result in eye or skin damage.

Flush this product in a well ventilated area.

Do Not use kerosene or other combustiblesolvents to flush this product.

Failure to follow these instructions can result in eye injury or other serious injury.

Always open from the back side first.

Use proper tools to open the fasteners.

- a. Remove the Silencer (26) and clean.
- b. For IEC/ Nema motor: Unscrew allen bolt (14) with Spring washer (18) and remove the Flange (2A).
- c. For Foot mount motor: Unscrew allen bolt (24) with Spring washer (25) and remove the Foot mounting bracket (23).
- d. Remove the Key (12) from Rotor shaft (4).
- e. To remove Bearing Cap (5) form Rear flange (3) Un-screw Allen Bolts (11) with Spring Washer (19) from Bearing Cap then Remove O-ring (9) and replace with new one (if found damaged).
- f. Unscrew Allen Bolts (14) with Spring Washer (18) from Rear Flange (3), now Tap carefully to the Rotor shaft front end by using mallet to remove Rear flange (3) along with Rotor shaft (4).
- g. Now remove Blades (15), Leaf spring (20) and Pin (16) from Rotor shaft (4) and replace it with new ones (if found damaged).
- h. Now Separate the Rotor shaft (4) from Rear flange (3) carefully by using suitable pin & mallet.
- i. Now remove the Shim (17) and replace it with new one (if found damaged).
- j. Now remove the Bearing (7) from Rear flange (3) using Suitable pin & mallet and replace with new one (if found damaged/ Rubbing).
- k. Now to remove Front Bearing Cap (6) form Front flange (2) Unscrew CKS Bolts (21) from Bearing Cap then Remove O-ring (9) and Oil seal (10) and replace with new one (if found worn out).
- l. Now unscrew Allen Bolt (14) with Spring washer (18) from Front Flange (2), now to Separate the Front flange (2) from the Housing (1), place a piece of aluminum on the face of flange from other side of the Housing and carefully hit it with a mallet
- m. Now replace Shim (17) with new one (if found worn out).
- n. For IEC motor: Now remove internal circlip (22) by using circlip plier. Now Remove Oil seal (10) and Bearing (8) from Front flange (2) using suitable pin & mallet and replace it with new ones (if found damaged/Rubbing).
- o. After installation of Bearing (8) in the Front flange (2), insert the Rotor shaft (4) into the Front flange bearing precisely.
- p. Now insert the Pin's (16) into the Rotor shaft's (4) through holes (use small amount of grease to prevent Pins to fall during assembly).
- q. Now locate the above assembly with Shim (17) on the dowels of the Housing (ensure that holes of Housing, Flange & Shim are aligning together). Now tighten them with Allen bolt (14) & spring washer (18). Ensure that Rotor face is not above the housing face.
- r. Now place the Leaf spring (20) on Blades (15) (Ensure that leaf springs bent end is inside the slot of Blade).
- s. Insert the above blade assembly into the Rotor shaft (4) from rear side.
- t. Now insert the Bearing (7) into the Rear flange (3).
- u. Now place the above Flange assembly with Shim (17) on the Housing (1). (Ensure that holes of Housing, Flange & Shim are aligning together). Now tighten them with Allen bolt (14) with Spring washer (18).
- v. Now after assembly, ensure that Rotor Shaft (4) is rotating smoothly inside, else tap lightly on the rotor shaft front end or rear end until you obtain smooth rotation of Rotor Shaft.
- w. Once smooth rotation is achieved then follow the above step 'l' in reverse manner for IEC model and follow the step the 'i' in reverse manner for Face/Foot/ Nema models.
- x. Now follow the step 'd, c, b and a' in reverse manner to complete the assembly.

Reversible - 6VM Series, Air Motor - Exploded View

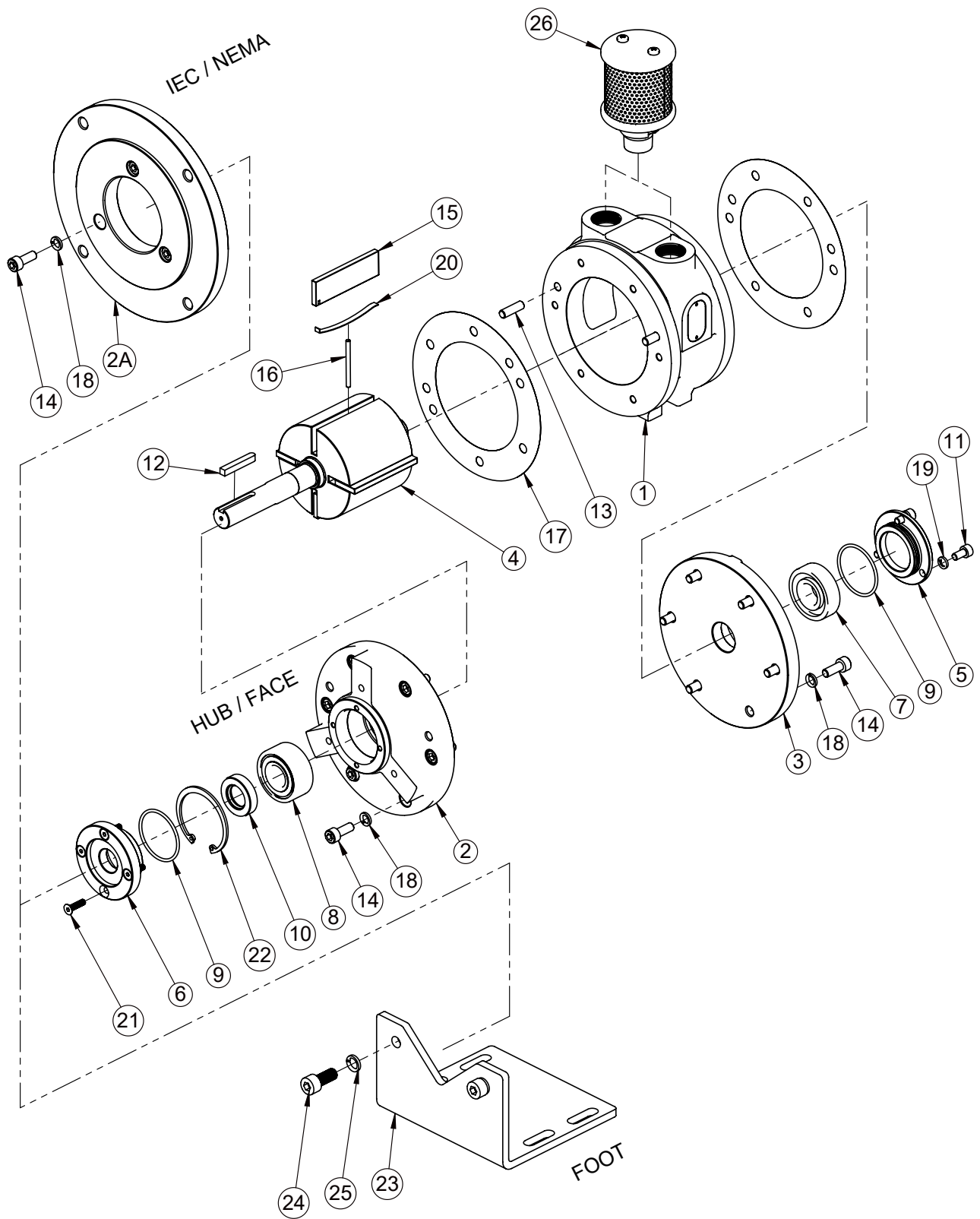

Reversible - 6VM Series, Air Motor - Parts List

Illu. No.	Part Number	Description	Face	Foot	IEC	Nema
1*	8050501	Housing-NPT	1	1	1	1
1**	8050507	Housing-BSPT	1	1	1	1
2	8050504	Front Flange-Face/Foot	1	1	-	-
2	8050511	Front Flange	-	-	1	-
2A	8050512	IEC Flange	-	-	1	-
2	8050514	Front Flange	-	-	-	1
2A	8050515	Nema Flange	-	-	-	1
3	8050503	Rear Flange	1	1	1	1
4	8052107	Rotor Shaft-Face/Foot	1	1	-	-
4	8052117	Rotor Shaft-IEC	-	-	1	-
4	8052119	Rotor Shaft-Nema	-	-	-	1
5	8052102	Rear Bearing Cap	1	1	1	1
6	8052111	Front Bearing Cap	1	1	-	1
7	8055002	Ball Bearing	2	2	1	1
8	8055003	Ball Bearing	-	-	1	-
8	1995035	Ball Bearing	-	-	-	1
9	8054001	O Ring	2	2	1	2
10	8056001	Oil Seal	1	1	-	1
10	8056002	Oil Seal	-	-	1	-
11	5509028	Allen Bolt	3	3	3	3
12	8052202	Key	1	1	-	-
12	8052204	Key	-	-	1	-
12	8032203	Key	-	-	-	1
13	8049004	Dowel Pin	4	4	4	4
14	8049003	Allen Bolt	12	12	15	15
15	8053902	Rotor Blade	4	4	4	4
16	8052108	Pin	2	2	2	2
17	8053701	Shim	4	4	4	4
18	5369004	Spring Washer	12	12	15	15
19	8059001	Spring Washer	3	3	-	-
20	8055102	Leaf Spring	4	4	4	4
21	8059004	Csk Bolt	4	4	-	4
22	5369001	Int. Circlip	-	-	1	-
23	8043102	Foot	-	1	-	-
24	8059007	Allen Bolt	-	2	-	-
25	1999047	Spring Washer	-	2	-	-
26*	8059801	Silencer-NPT	1	1	1	1
26**	8059802	Silencer-BSPT	1	1	1	1

Note -

- 1) " * " Marks part are applicable for NPT Models Only
- 2) " ** " Marks part are applicable for BSPT Models Only.

Repair Kits for 6VM

Repair KIT Ordering No	Suitable for
805 97 01	Suitable for 6VM Face / Foot & Nema variant
805 97 02	Suitable for 6VM IEC variant

Note - Repair Kit includes Blades, Bearings, Shims, Oil Seals and O rings

Dimension Drawings

Model - 6VMD (IEC)

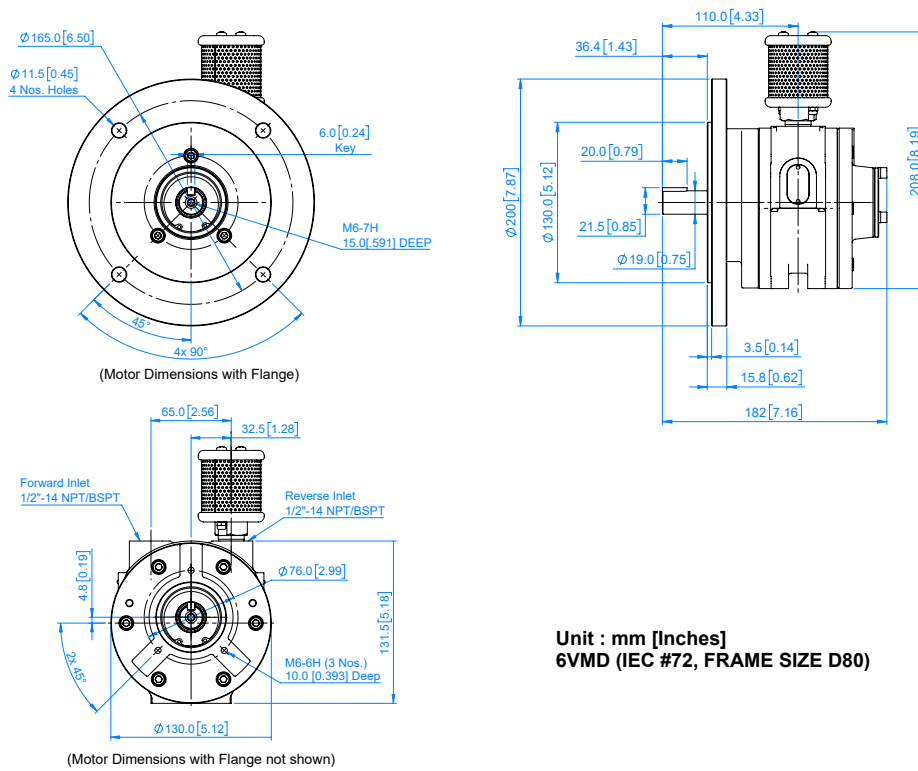

Model - 6VMN (NEMA)

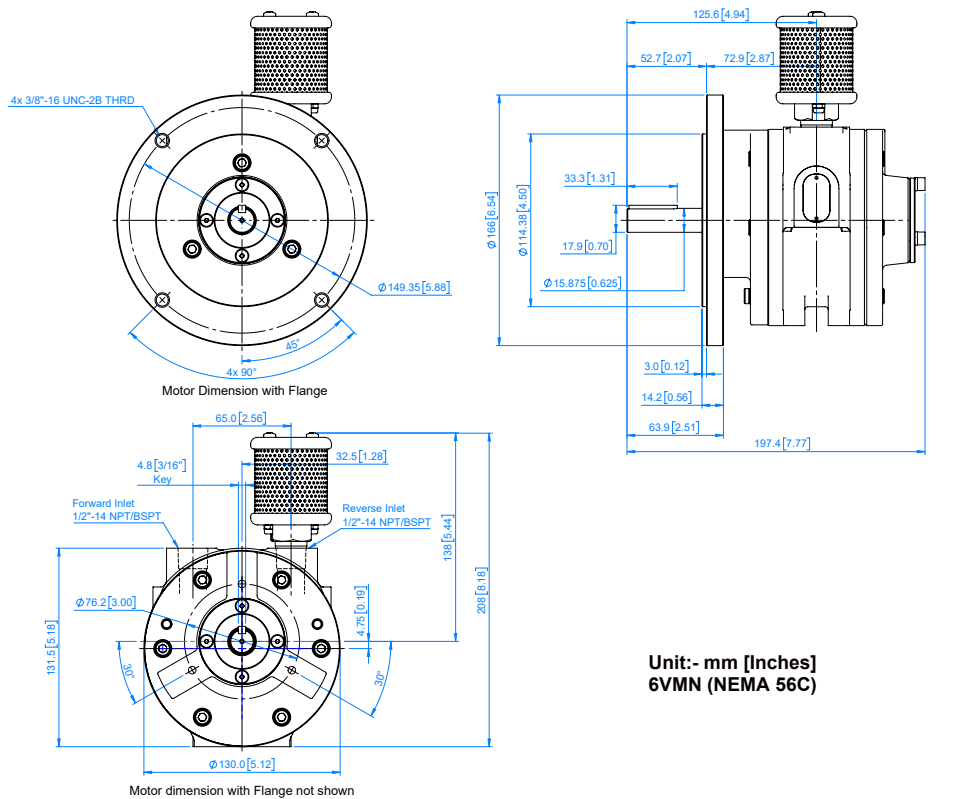

Dimension Drawings

Model - 6VML (FACE)

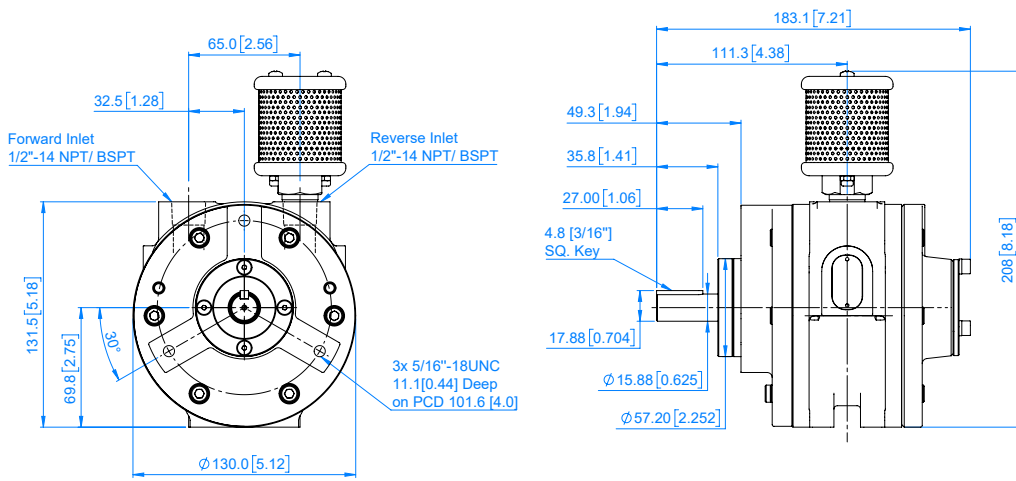

**Unit:- mm [Inches]
6VML (FACE)**

Model - 6VMS (FOOT)

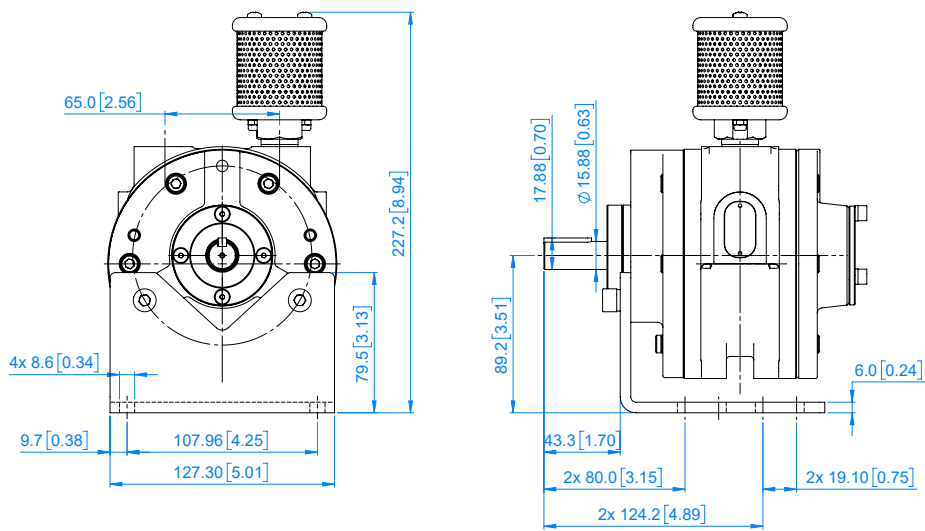

**Unit:- mm [Inches]
6VMS (FOOT)**

Reversible - 8VM Air Motor

Dis assembly and Re-assembly

Disconnect air supply and vent all air lines. Air stream from product may contain solid or liquid material that can result in eye or skin damage.

Flush this product in a well ventilated area.

Do Not use kerosene or other combustiblesolvents to flush this product.

Failure to follow these instructions can result in eye injury or other serious injury.

Always open from the back side first.

Use proper tools to open the fasteners.

- a. Remove the Silencer (26) and clean.
- b. For IEC/ Nema motor: Unscrew allen bolt (22) with Spring washer (21) and remove the Flange (2A).
- c. For Foot mount motor: Unscrew allen bolt (24) with Spring washer (25) and remove the Foot mounting bracket (23).
- d. Remove the Key (13) from Rotor shaft (4).
- e. To remove Bearing Cap (5) form Rear flange (3) Unscrew Allen Bolts (14) with Spring Washer (16) from Bearing Cap then Remove O-ring (7) and replace with new one (if found damaged).
- f. Unscrew Allen Bolts (15) with Spring Washer(18) from Rear Flange (3), now Tap carefully to the Rotor shaft front end by using mallet to remove Rear flange (3) along with Rotor shaft (4).
- g. Now remove Shim (8), Blades (6), Leaf spring (11) and Pin (17) from Rotor shaft (4) and replace it with new ones (if found damaged).
- h. Now Separate the Rotor shaft (4) from Rear flange (3) carefully by using suitable pin & mallet.
- i. Now remove the Bearing (10) from Rear flange (3) using Suitable pin & mallet and replace with new one (if found damaged/ Rubbing).
- j. Now remove internal circlip (19) by using circlip plier. Now remove Oil seal (12) and Bearing (9) from Front flange (2) using suitable pin & mallet and replace with new ones (if found damaged/Rubbing).
- k. Now unscrew Allen Bolt (15) with Spring washer (18) from Front Flange (2), now to Separate the Front flange (2) from the Housing (1), place a piece of aluminum on the face of flange from other side of the Housing and carefully hit it with a mallet.
- l. Now replace Shim (8) with new one (if found worn out).
- m. After installation of Bearing (9) in the Front flange (2), insert the Rotor shaft (4) into the Front flange bearing precisely.
- n. Now insert the 2 no.s Pins (17) into the Rotor Shaft's (4) through holes (use small amount of grease to prevent Pins to fall during assembly).
- o. Now locate the above assembly with Shim (8) on the dowels of the Housing (ensure that holes of Housing, Flange & Shim are aligning together). Now tighten them with Allen bolt (15) & spring washer (18). Ensure that Rotor face is not above the housing face.
- p. Now place the Leaf spring (11) on Blades (6) (Ensure that leaf springs bent end is inside the slot of Blade).
- q. Insert the above blade assembly into the Rotor shaft (4) from rear side.
- r. Now insert the Bearing (10) into the Rear flange(3).
- s. Now place the above Flange assembly with Shim (8) on the Housing (1). (Ensure that holes of Housing, Flange & Shim are aligning together). Now tighten them with Allen bolt (15) with Spring washer (18).
- t. Now after assembly, ensure that Rotor Shaft (4) is rotating smoothly inside, else tap lightly on the rotor shaft front end or rear end until you obtain smooth rotation of Rotor Shaft.
- u. Once smooth rotation is achieved then follow the above step 'l' in reverse manner for IEC model and follow the step the 'i' in reverse manner for Face/ Foot/Nema models.
- v. Now follow the step 'c, b and a' to complete the assembly.

Reversible - 8VM Series, Air Motor - Exploded View

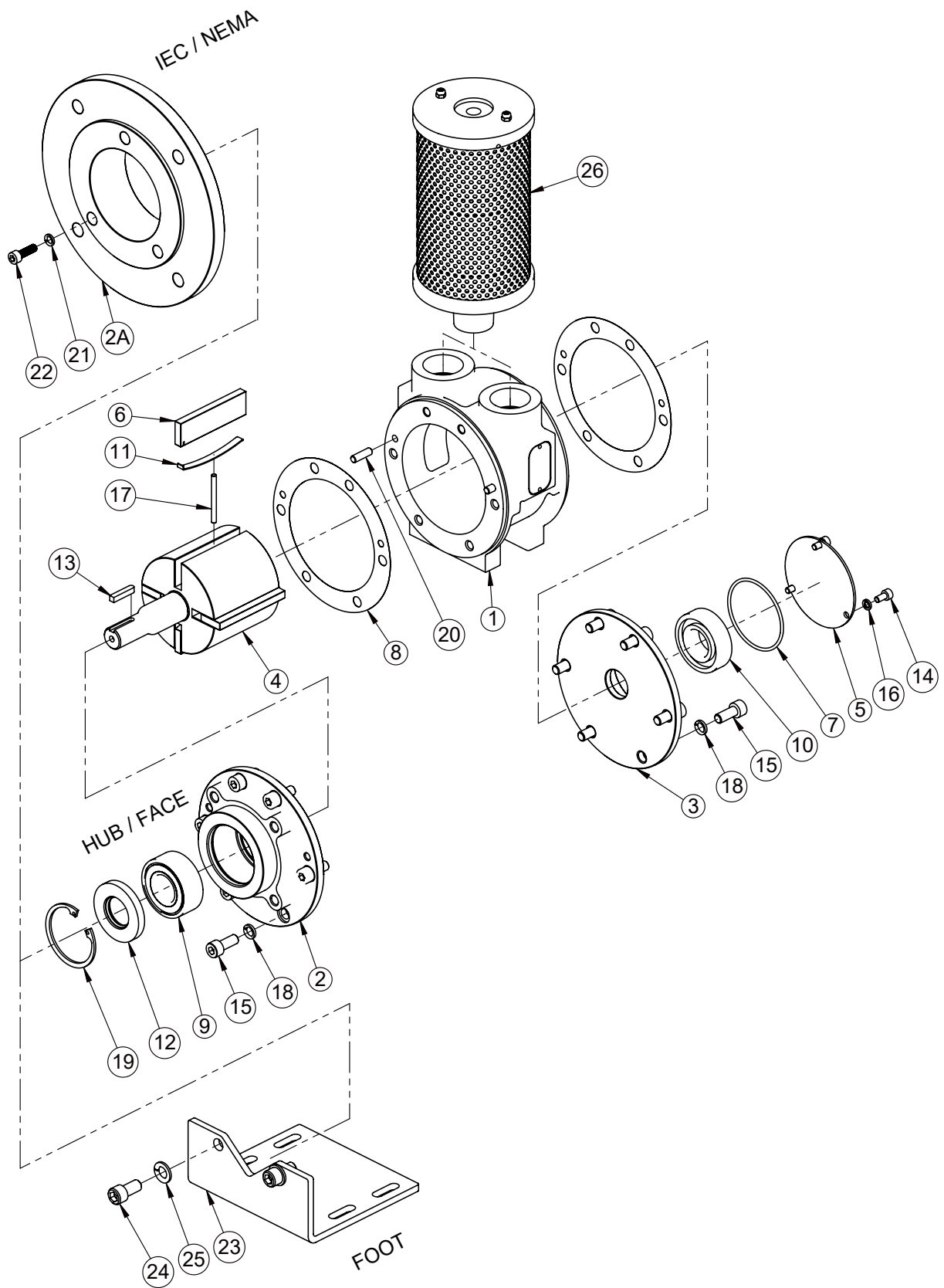

Reversible - 8VM Series, Air Motor - Parts List

Illu. No.	Part Number	Description	Face	Foot	IEC	Nema
1*	8060501	Housing-NPT	1	1	1	1
1**	8060506	Housing-BSPT	1	1	1	1
2	8060508	Front Flange-Face/Foot	1	1	-	-
2	8060507	Front Flange	-	-	1	1
2A	8060509	IEC Flange	-	-	1	-
2A	8060510	Nema Flange	-	-	-	1
3	8060503	Rear Flange	1	1	1	1
4	8062114	Rotor Shaft-Face/Foot	1	1	-	-
4	8062112	Rotor Shaft-IEC	-	-	1	-
4	8062113	Rotor Shaft-Nema	-	-	-	1
5	8062102	Bearing Cap	1	1	1	1
6	8063901	Rotor Blade	4	4	4	4
7	8064001	O Ring	1	1	1	1
8	8063701	Shim	4	4	4	4
9	8065001	Ball Bearing	1	1	1	1
10	5505033	Ball Bearing	1	1	1	1
11	8065101	Leaf Spring	4	4	4	4
12	8066001	Oil Seal	1	1	1	1
13	8062205	Key	1	1	-	1
13	6533110	Key	-	-	1	-
14	5509028	Allen Bolt	3	3	3	3
15	1269040	Allen Bolt	12	12	12	12
16	8059001	Spring Washer	3	3	3	3
17	8062104	Pin	2	2	2	2
18	1999047	Spring Washer	12	12	12	12
19	8069002	Int. Circlip	1	1	1	1
20	8049004	Dowel Pin	4	4	4	4
21	5369004	Spring Washer	-	-	3	3
22	5009041	Allen Bolt	-	-	3	3
23	8063102	Foot	-	1	-	-
24	8069003	Allen Bolt	-	2	-	-
25	2109035	Spring Washer	-	2	-	-
26*	8069801	Silencer-NPT	1	1	1	1
26**	8069802	Silencer-BSPT	1	1	1	1
26**	8059802	Silencer-BSPT	1	1	1	1

Note -

- 1) " * " Marks part are applicable for NPT Models Only
- 2) " ** " Marks part are applicable for BSPT Models Only.

Repair Kits for 8VM

Repair KIT Ordering No	Suitable for
806 97 01	Suitable for 8VM - 4Vanes Hub / Foot / IEC & Nema variant
806 97 02	Suitable for 8VM - 8Vanes Hub / Foot / IEC & Nema variant

Note - Repair Kit includes Blades, Bearings, Shims, Oil Seals and O rings

Dimension Drawings

Model - 8VMD (IEC)

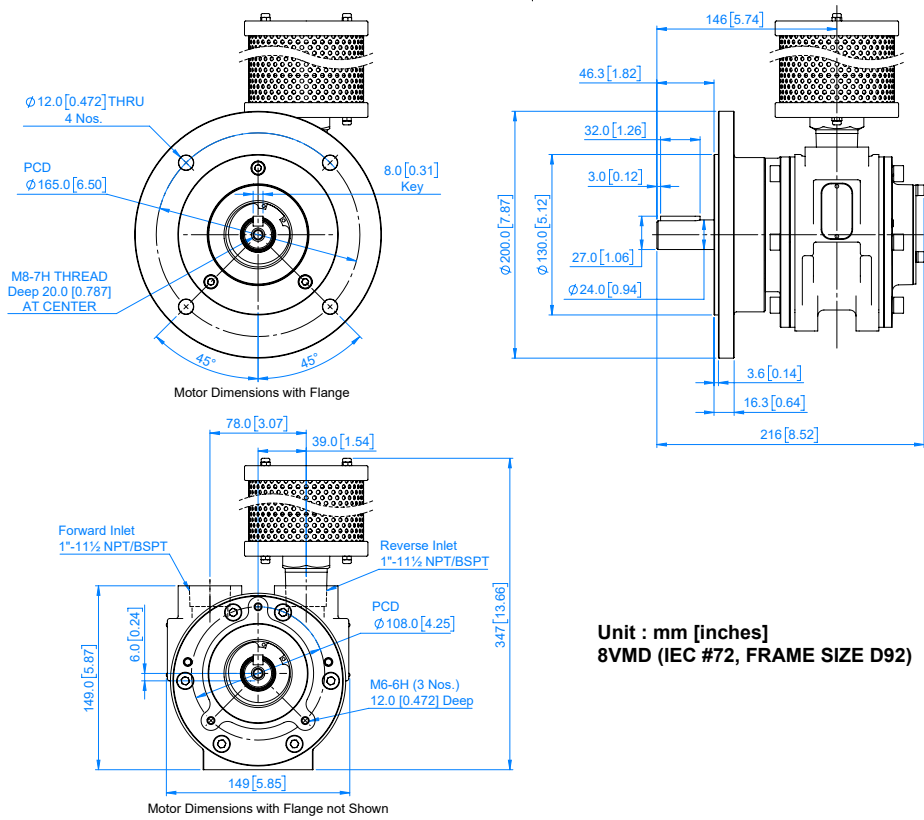

Model - 8VMN (NEMA)

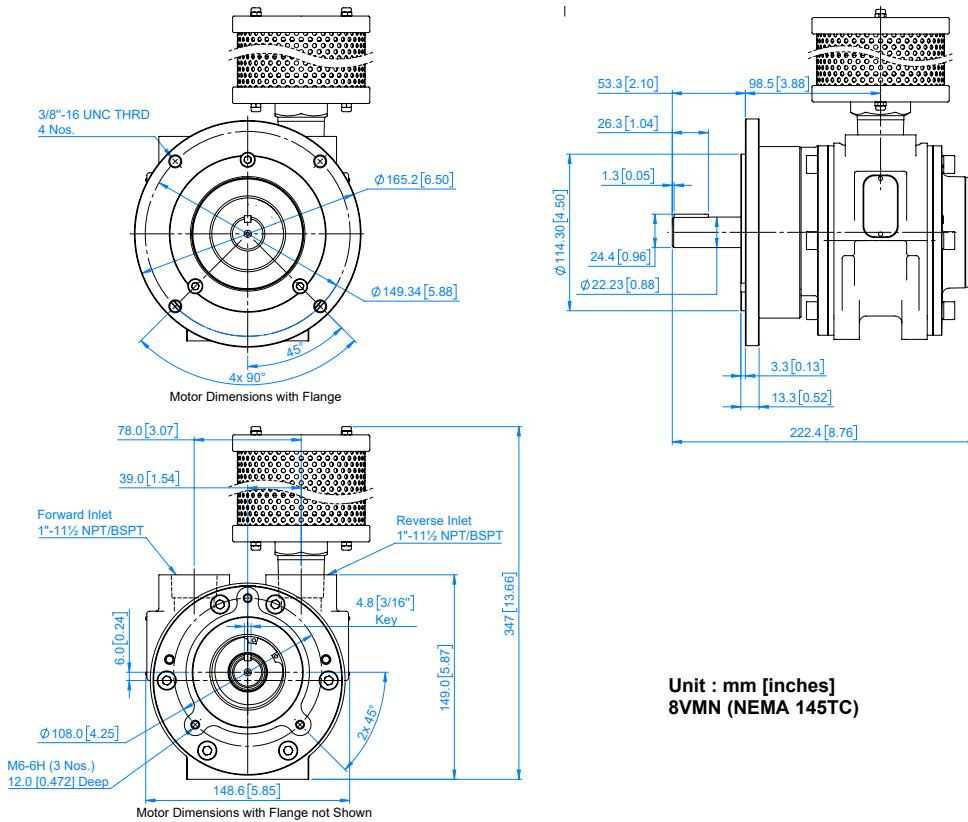

Dimension Drawings

Model - 8VML (FACE)

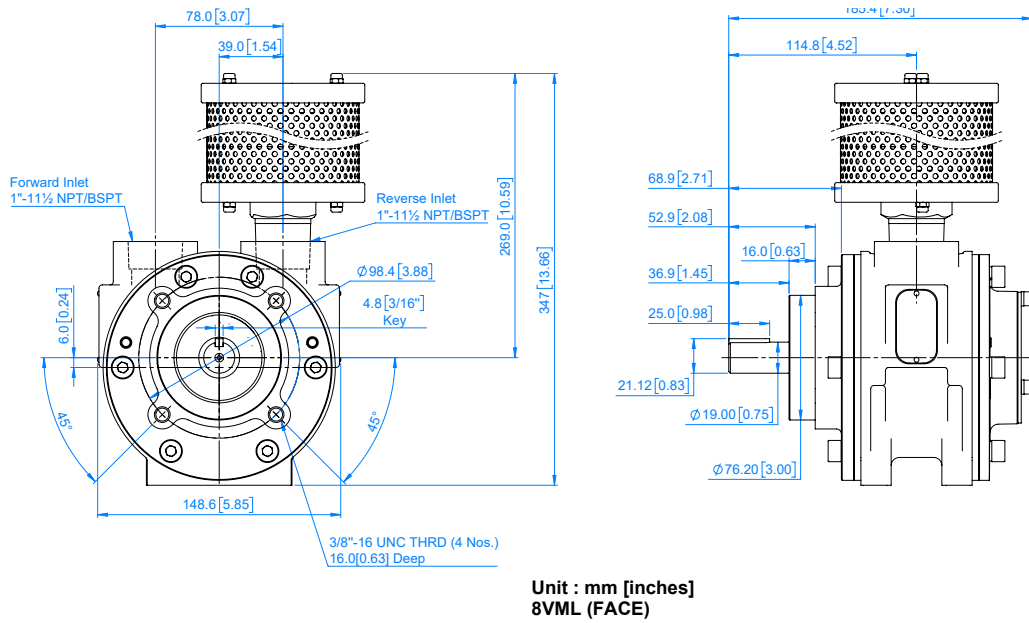

Model - 8VMS (FOOT)

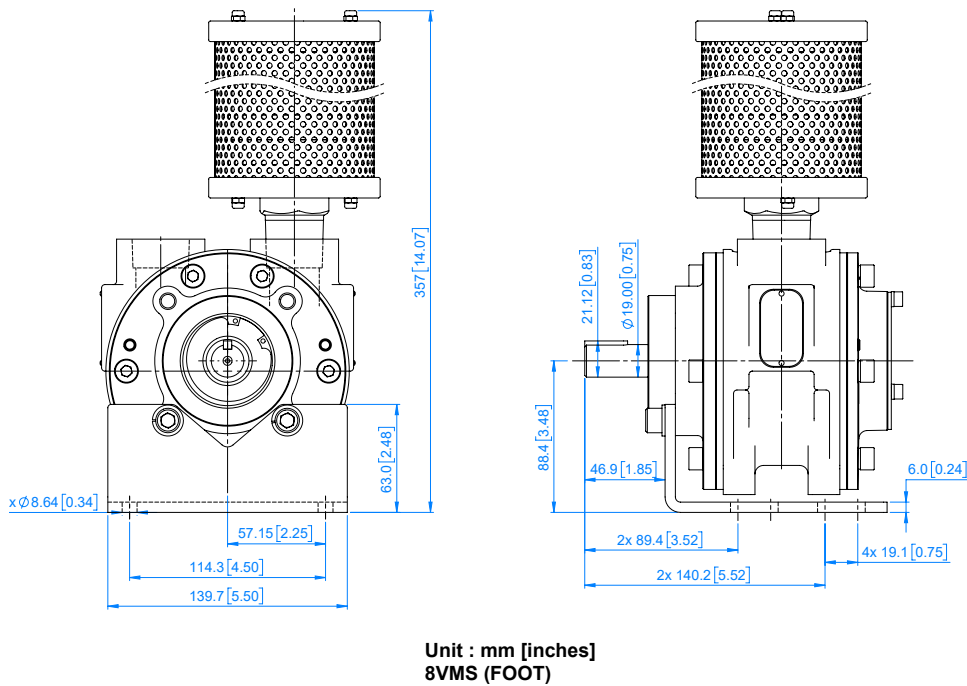

Reversible - 16VM Air Motor

Dis assembly and Re-assembly

Disconnect air supply and vent all air lines. Air stream from product may contain solid or liquid material that can result in eye or skin damage.

Flush this product in a well ventilated area.

Do Not use kerosene or other combustiblesolvents to flush this product.

Failure to follow these instructions can result in eye injury or other serious injury.

Always open from the back side first.

Use proper tools to open the fasteners.

- a. Remove the Silencer (27) and clean.
- b. Remove the Key (8) from Rotor shaft (6).
- c. To Remove the Bearing Cap (5) form Rear flange (3) Unscrew Hex Bolts (19) from Bearing Cap then Re-move O-ring (11) and replace with new one (if found damaged).
- d. Now to Remove front Bearing cap (4) from Front Flange (2), Unscrew Hex bolt (19) from Front Bearing Cap (4). Then remove O-ring (11) and Oil Seal (15) from Front Bearing Cap (4) and replace with new one (if found damaged).

[For Nema model: Unscrew the Allen bolt (20) with Spring washer (2 k. Now unscrew Hex Bolt (21) from

- e. Now unlock Lock washer (18) from the slot of Lock nut (17) using minus screw driver, now to Unscrew Lock nut (17). Remove Lock washer (18) from Rotor Shaft (6) and replace with new ones (if found damaged).
- f. Unscrew Hex Bolts (21) from Rear Flange (3), now Tap carefully to the Rotor shaft front end by using mallet to remove Rear flange (3) along with Rotor shaft (6).
- g. Now remove Blades (10), Leaf spring (14) and Pin (7) from Rotor shaft (6) and replace it with new ones (if found damaged).
- h. Now Separate the Rotor shaft (6) from Rear flange (3) carefully by using suitable pin & mallet.
- i. Now remove the Shim (9) and replace it with new one (if found worn out).
- j. Now remove Bearing (12) from Rear Flange (3) using Suitable pin & mallet and replace with new one (if damaged/ Rubbing).

- k. Now unscrew Hex Bolt (21) from Front Flange (2), now to Separate the Front flange (2) from the Housing (1), place a piece of aluminum on the face of flange from other side of the Housing and carefully hit it with a mallet.

[For Nema model: Unscrew Hex Bolt (23) with Spring washer (24)]

[For IEC motor: Unscrew allen bolt (26) with Spring washer (25) and remove the Flange (2A), then follow the above step ‘j’]

- l. Now remove Ball bearing (13) from Front Flange (2) by using suitable pin & malate . Replace it with new ones (if worn-out).
- m. Now insert the Rotor Shaft (6) into the bearing of Front Flange by using press/ mallet precisely.
- n. Now insert Pins (7) into the Rotor Shaft’s (6) through holes (use small amount of grease to prevent Pins to fall during assembly).
- o. Now locate the above assembly with Shim (17) on the dowels of the Housing (ensure that holes of Housing, Flange & Shim are aligning together). Now tighten them with Allen bolt (14) & spring washer (18). Ensure that Rotor face is not above the housing face.
- p. Now insert Lock Washer (18) into the Rotor Shaft (6) and fasten Lock Nut (17). Now secure the Lock Nut (17) by pressing one end of Lock Washer (18) into slot of Lock Nut (17).
- q. Now install O-ring & Oil seal on Front Bearing Cap (4), then install the Front Bearing Cap (4) on Front Flange (2) by fastening (Hex Bolt (19) for Face mount models and Allen Bolt (20) with Spring Washer (22) for Nema models).
- r. Now place the Leaf Spring (11) on Rotor Blades (6), ensure that leaf spring one end is inside the slot of Rotor Blade (6).
- s. Insert the above blade assembly one at a time into Rotor Shaft (6).
- t. Now follow the above steps ‘c’ & ‘b’ in reverse manner to assemble the motor.
- u. Now after assembly, ensure that Rotor Shaft (6) is rotating smoothly inside, else tap lightly on the rotor shaft front end or rear end until you obtain smooth rotation of Rotor Shaft (6). Once smooth rotation is achieved follow the step ‘a’ in reverse manner and complete the assembly.

Reversible - 16VM Series, Air Motor - Exploded View

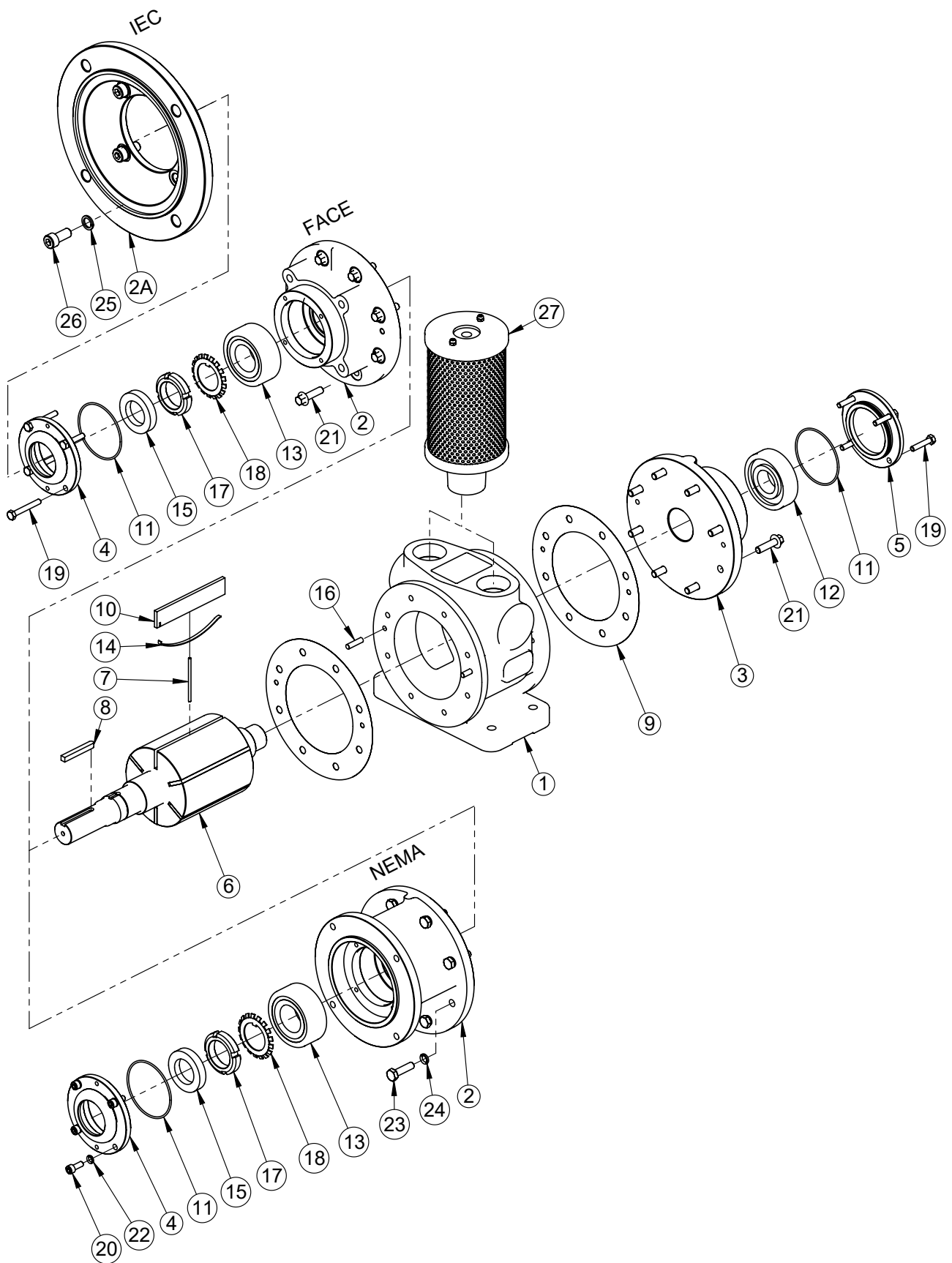

Reversible - 16VM Series, Air Motor - Parts List

Illu. No.	Part Number	Description	FACE/ FOOT	IEC	NEMA
1*	8100501	Housing-NPT	1	1	1
1**	8100508	Housing-BSPT	1	1	1
2	8100502	Front Flange-Face/Foot	1	1	-
2A	8100507	Front Flange-IEC	-	1	-
2	8100506	Front Flange-Nema	-	-	1
3	8100503	Rear Flange	1	1	1
4	8100504	Front Bearing Cap	1	1	1
5	8100505	Rear Bearing Cap	1	1	1
6	8102102	Rotor Shaft	1	-	-
6	8102101	Rotor Shaft-IEC	-	1	-
6	8102105	Rotor Shaft-NEMA	-	-	1
7	8102103	Solid Dowel Pin	3	3	3
8	8102202	Key	1	-	-
8	8102201	Key-IEC	-	1	-
8	8042204	Key-Nema	-	-	1
9	8103701	Shim	4	4	4
10	8103901	Rotor Blade	6	6	6
11	8104001	O Ring	2	2	2
12	8105001	Bearing 2Z/ZZ	1	1	1
13	8105002	Bearing 2Z/ZZ	1	1	1
14	8105101	Leaf Spring	6	6	6
15	8106001	Oil Seal	1	1	1
16	8109001	Solid Dowel Pin	4	4	4
17	8109003	Lock Nut	1	1	1
18	8109004	Lock Washer	1	1	1
19	8109005	Hex Bolt	8	8	4
20	8049003	Allen Bolt	-	-	4
21	8109006	Flanged Hex Bolt	16	16	8
22	5369004	Spring Washer	-	-	4
23	5369006	Hex Bolt	-	-	8
24	1999047	Spring Washer	-	-	8
25	6539004	Spring Washer	-	4	-
26	8109014	Allen Bolt	-	4	-
27*	6374030	Muffler- NPT	1	1	1
27**	8105004	Muffler- BSPT	1	1	1

Note -

- 1) * * Marks part are applicable for NPT Models Only
- 2) ** * Marks part are applicable for BSPT Models Only.

Repair Kits for 16VM

Repair KIT Ordering No	Suitable for
810 97 01	Suitable for 16 VM all variant

Note - Repair Kit includes Blades, Bearings, Shims, Oil Seals and O rings

Dimension Drawings

Model - 16VML (FACE) & 16VMS (FOOT)

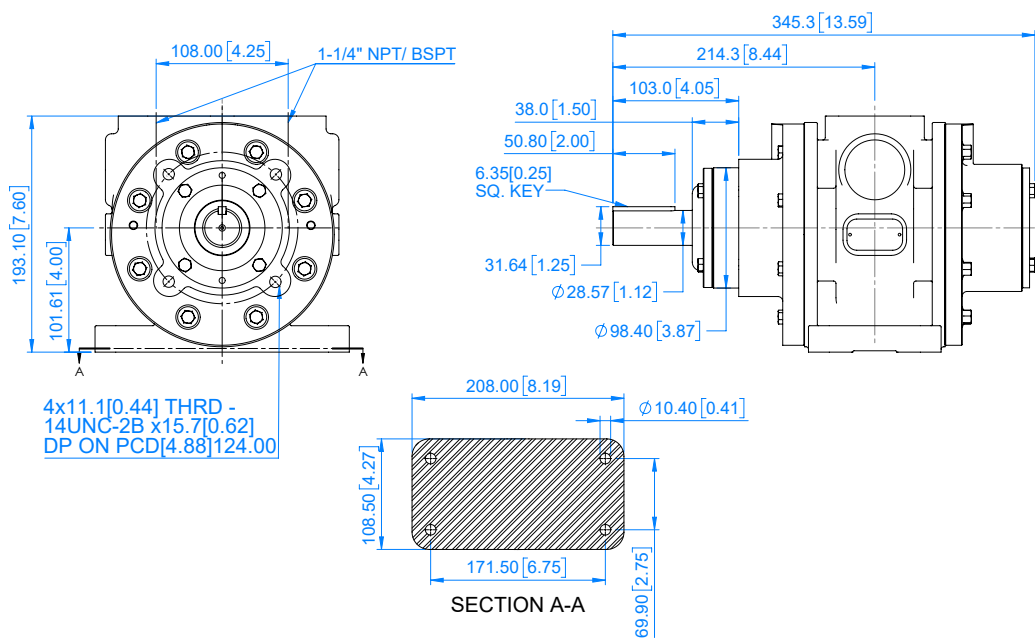

mm [Inches]

Face & Foot

16VML & 16VMS

Model - 16VMN (NEMA)

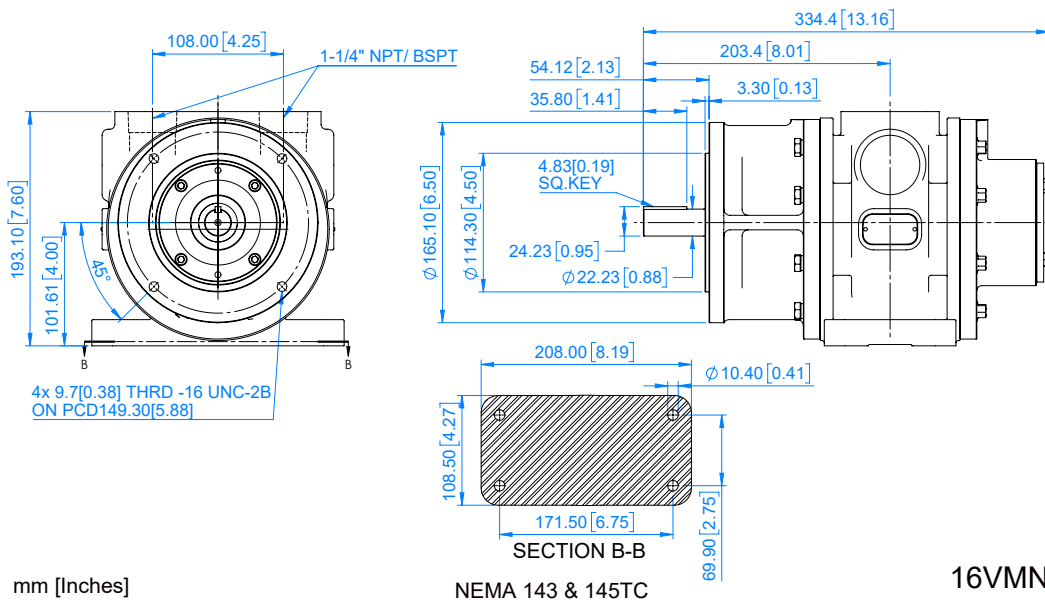

mm [Inches]

NEMA 143 & 145TC

16VMN

Dimension Drawings

Model - 16VMD (IEC)

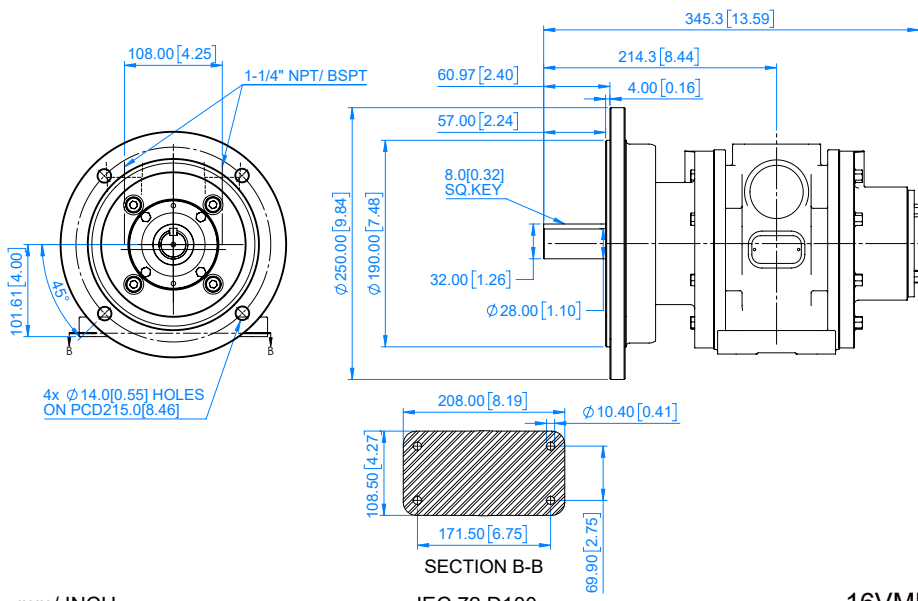



Conditions for use in ATEX Atmosphere

Ex Code

Model : 1VM Series, 2VM Series,
4VM Series, 6VM Series.

⊕ II 2 GD Ex h IIC T6 Gb
⊕ II 2 GD Ex h IIIC T85°C Db

Model : 8VM Series, and 16VM Series

⊕ II 2GD Ex h IIC T4 Gb
⊕ II 2GD Ex h IIIC T135°C Db

Amb. Temp (+1° C to +40° C)

Rotary Air Motors

Designed for Operation in Hazardous and Explosive
Environments

NOTICE

The EC Declaration of Incorporation provided in this manual certifies that these Air Motors have been evaluated as components in accordance with European Community Directive 2014/34/EU, also known as the ATEX Directive, which applies to equipment intended for use in potentially explosive atmospheres.

These Air Motors have been tested and verified for compliance under the specified ATEX

NOTICE

All special conditions must be adhered to for this product to comply with the ATEX Directive and to maintain the validity of the ATEX Declaration of Incorporation.

Specific Conditions for Safe Application, Installation, Operation, and Maintenance

⚠ WARNING

- Failure to adhere to these special conditions may lead to the ignition of explosive atmospheres.
- Rubbing or friction can generate sparks or elevated temperatures, potentially igniting an explosive atmosphere.

Application and Installation

- Vibration Monitoring: Measure and document acceptable vibration levels during the operation of the fully installed motor to ensure compliance with safety standards.
- Work Permit System: Implement a Work Permit System to confirm that explosive atmospheres are absent in the operational zone before and during motor use.
- Installation Precautions: Do not install, maintain, or remove the motor from the system if a potentially explosive atmosphere is present.
- Static Discharge Prevention: To mitigate the risk of ignition from electrostatic discharge, ensure the motor is continuously and properly grounded. A resistance to earth of less than 10,000 ohms is required.

Motor Operation Conditions

- Rated Air Pressure: Never exceed the rated air pressure indicated on the Air Motor housing label. Operating above the specified pressure can lead to premature failure of bearings or other components due to excessive speed, torque, or force, potentially creating an ignition source.

- **Surface Temperature Monitoring:** Elevated surface temperatures may indicate overload or impending failure of bearings or other mechanical components, potentially creating an ignition hazard.
- **System Surface Temperature:** Measure and document the maximum surface temperature (Tmax) of the entire system incorporating the motor. (a) Ensure that this is below the stated Tmax see code
- **Bearing Temperature Limit:** Bearings should not operate at temperatures exceeding 60°C for extended periods.
- **Temperature Monitoring:** Regularly monitor the Air Motor bearings and housing for unusually high temperatures during operation.
- **Measured Maximum Temperature:** The Air Motor's maximum surface temperature (Tmax) was determined with an ambient temperature of 21°C. This measurement was conducted under no-load, free-speed, and maximum pressure conditions until the temperature stabilized.
- If abnormal vibration or elevated temperatures are detected, discontinue use immediately and inspect or repair the Air Motor.

• **Bearing Overload Prevention:**

Bearing overload may lead to premature failure due to rubbing and friction. Follow these guidelines to avoid overload:

- Consult catalog data or an Teryair Technical Specialist for detailed technical information and guidance.
- Ensure driven loads are balanced to prevent excessive radial vibration and abnormal bearing stress.
- Avoid contact between the motor shaft and other rotating or oscillating components.
- Enclose or guard all moving parts to enhance safety.
- Securely mount the Air Motor to prevent abnormal operation or accidental detachment.
- Protect the Air Motor from impacts that could generate sparks or damage component

Operation

Always use clean, dry air and ensure proper lubrication as specified in the product manual. Do not exceed the maximum air pressure indicated on the motor. Exceeding this pressure may lead to hazardous conditions, such as excessive speed or incorrect output torque and force, which could cause premature bearing failure or other component damage.

Refer to the specifications for the correct airline lubrication requirements.

Maintenance

Adhere to all lubrication and maintenance instructions outlined in the manual supplied with the Air Motor.

- **Hazardous Area Warning:** Do not perform maintenance or repairs in areas where hazardous atmospheres are present.
- **Cleaning and Lubrication Precautions:** Never clean or lubricate the Air Motor with flammable or volatile liquids such as kerosene, diesel, or jet fuel, as these may create a potentially explosive atmosphere.

NOTICE

- Include the recommendations provided in these special conditions, along with any similar suggestions identified through the explosive hazard assessment of the complete machine, in the accompanying documentation of the machine into which the Air Motor is incorporated.
- To ensure safe operation of this product and compliance with the Machinery Directive 2006/42/EC, it is essential to follow all instructions in the accompanying literature, as well as all conditions, notices, and warnings specified herein.
- The EC Declaration of Incorporation included in this manual confirms that the listed products and models have been evaluated for compliance with European Community Directive 2014/34/EU, which governs equipment for use in potentially explosive atmospheres. Air Motors are designed to be integrated into larger machines. However, Teryair Company Limited cannot predict all potential applications of this component and, therefore, cannot provide safety guidance for the entire larger machine. It is the responsibility of the machine builder to ensure that the entire system, including all components, complies with safety requirements for application, installation, operation, inspection, and maintenance according to relevant standards and regulations (local, state, national, federal, etc.). If the completed machine is intended for sale in the European Union, it remains the builder's responsibility to properly safeguard, warn, identify, label, and mark the product accordingly and to provide the Declaration of Incorporation for applicable directives.

CE Declaration of Incorporation

Object Of Declaration

Product : Pneumatic Vane Motors

Model : 1VM, 2VM, 4VM, 6VM, 8VM, 16VM

Manufacturer's Name : Teryair Equipment Pvt. Ltd.

Address : Site - 1: Building A - 1/2, 102 To 105 & Building C 12 & 13,
Tirupati Udyog Nagar, Sativali Road, Vasai (E), Palghar : 401208.

Site - 2: Augustine - Ii, Colaco Industrial Complex, Gala No
101 To 107, Sativali Road, Village Waliv, Vasai (E), Palghar: 401208

In accordance with Directive 2006/42/EC (Machinery) and Directive 2014/34/EU (ATEX), conformity is assured by applying the following harmonized standards and normative documents, as published in the Official Journals of the European Union:

Applicable Directive : 2006/42/EC (Machinery) and 2014/34/EU (ATEX)

Applicable Standards : EN ISO 12100:2010, EN 1127-1:2011, EN ISO 80079-36:2016,
EN ISO 80079-37:2016, EN ISO 60079-0, and EN ISO 4414:2010

En Iso 80079-36: 2016 : Explosive Atmospheres — Part 36: Non-Electrical
Equipment for Explosive Atmospheres - Basic Method and Requirements.



En Iso 80079-37:2016 : Explosive Atmospheres — Part 37: Non-Electrical Equipment for Explosive
Atmospheres - Non-Electrical Type of Protection: Constructional Safety 'C',
Control of Ignition Sources 'B', Liquid Immersion 'K'.

Notified Body To Whom Technical File Has Logged With: - Technicka Inspekcja (Ref: 1354).



Declaration: - Teryair Equipment Pvt. Ltd. hereby declares, under its sole responsibility, that the product defined above complies with all applicable directives, regulations, and essential health and safety requirements.

I, The Undersigned, Hereby Declare That The Product Specified Above Conforms To The Above Standard(S).

Atex Marking Applied: Model : 1VM Series, 2VM Series, 4VM Series, 6VM Series.

 II 2 GD Ex h IIC T6 Gb
 II 2 GD Ex h IIC T85°C Db

Model : 8VM Series, and 16VM Series

 II 2GD Ex h IIC T4 Gb
 II 2GD Ex h IIC T135°C Db

Signed For And On Behalf Of

 Mr. M. Yadav
 Q.A. Manager
 Teryair Equipment Pvt. Ltd.

Place Of Issue : Vasai



Warranty Certificate

Every product manufactured by Teryair
is built to meet the highest standards of quality.

Teryair warrants that the Products, accessories and parts manufactured or supplied by the company be free from defects in material and workmanship for a period of twelve months from date of Teryair authorized dealer invoice to customer, or one year from date of Teryair invoice to dealer, whichever is earlier. Failure due to normal wear, misapplication, or abuse is, of course, excluded from this warranty.

Since the use of Teryair products and parts is beyond our control, Teryair cannot guarantee the suitability of any product or part for a particular application and Teryair shall not be liable for any consequential damage or expense arising from the use or misuse of its products on any application. Teryair does not warranty bought out products or components such as electric motors and hardware but will assist in directing warranty queries to the dealer/manufacturer responsible. Teryair responsibility is limited solely to replacement or repair of defective Teryair products or components.

Dealer/End User shall have no right or remedy and Teryair shall have no liability or obligation under the warranty, if: (i) a Product is altered, changed, modified or tampered with in any way, (ii) a Product is damaged after deposit with the transporter for shipment; (iii) a Product is not properly preserved, packaged, stored, processed or handled after receipt; (iv) a Product is not used and maintained in accordance with Teryair's recommended operating and maintenance manuals, instructions and procedures, if any; (v) a Product is not properly incorporated or installed in, or not properly combined with, an Other Product; (vi) the issue with a Product is directly or indirectly attributable to, or directly or indirectly results from or arises out of, a failure, substandard performance or other issue with another product, material, component or part not supplied by Teryair; (vii) the issue with a Product is directly or indirectly attributable to, or directly or indirectly results from or arises out of, compliance with any design, specification or other specific requirement of Dealer/End User; (viii) a Product is used in a manner, with a substance or for a purpose other than the normal manner, substance and purpose for which it is intended or is otherwise subjected to abnormal use or service; (ix) a Product is subjected to a power surge, brown out or other similar occurrence; (x) the issue with a Product is directly or indirectly attributable to, or directly or indirectly results from or arises out of, normal wear and tear of such Product (including, without limitation, things such as worn seals, diaphragms, balls, O rings, gaskets, chisels, cutters, hoses and other such wearing components; (xi) the issue with a Product is directly or indirectly

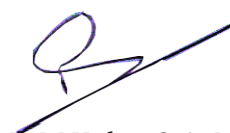

Mr. M. Yadav, Q.A. Manager
(Company Seal)

This page is intentionally
Left blank.

www.teryair.com
©2025 Teryair

