



### Operation and Maintenance Guide



VF

Models	Descriptions	IMPA Number
VF-200-110V	Electrical Ventilation Fan, 200mm 100V-1ph	59 14 02
VF-200-200V	Electrical Ventilation Fan, 200mm 200V-1ph	59 14 06
VF-300-100V	Electrical Ventilation Fan, 300mm 100V-1ph	59 14 03
VF-300-200V	Electrical Ventilation Fan, 300mm 200V-1ph	59 14 07
VF-400-110V	Electrical Ventilation Fan, 400mm 110V-1ph	-
VF-400-200V	Electrical Ventilation Fan, 400mm 200V-3ph	59 14 08
VF-400-200V	Electrical Ventilation Fan, 400mm 200V-1ph	59 14 08A
VF-400-200V	Electrical Ventilation Fan, 400mm 400V-3ph	59 14 08B
VF-500-200V	Electrical Ventilation Fan, 500mm 200V-3ph	59 14 09
VF-500-200V	Electrical Ventilation Fan, 500mm 200V-1ph	59 14 09A
VF-500-200V	Electrical Ventilation Fan, 500mm 400V-3ph	59 14 09B

Read this manual carefully before installing, operating or servicing this equipment. It's the responsibility of the employer to ensure this manual is read by the operator. Please preserve this manual.

This document is issued with Product Serial No

<<Serial No>>

## Table of Contents

3	Introduction
3	Technical Data
3	Safety Instructions
3	Operation
3	Maintenance
4	Dimensional Data
5	Eu Declaration Of Conformity
6	Warranty Certificate

## Introduction

Teryair Electric Ventilation Fans are highly efficient and portable. Used to ventilate hot air and harmful gases from a tank or work area, and supply fresh air. The ideal bell mouth type casing is highly efficient, creates little noise and is easy to install in an air duct. Ducting tubes sold separately.

## Technical Data

Product Reference	VF-200-100V	VF-200-200V	VF-300-100V	VF-300-200V	VF-400-110V	VF-400-200V
Casing Diameter	Ø200mm	Ø200mm	Ø300mm	Ø300mm	Ø400mm	Ø400mm
Electric Source	100V - 1ph	200V - 1ph	100V - 1ph	200V - 1ph	110V - 1ph	200V - 3ph
Air volume	20 M <sup>3</sup> / min	20 M <sup>3</sup> / min	70 M <sup>3</sup> / min	70 M <sup>3</sup> / min	70 M <sup>3</sup> / min	110 M <sup>3</sup> / min
R.P.M.	3000	3600	3000	3600	1400	3000
Output	0.16 kw	0.16 kw	0.55 kw	0.55 kw	0.37 kw	1.5 kw
Weight	9 kgs	9 kgs	15kgs	15 kgs	22 kgs	28 kgs

## Technical Data

Product Reference	VF-400-200V	VF-400-400V	VF-500-200V	VF-500-200V	VF-500-400V
Casing Diameter	Ø400mm	Ø400mm	Ø500mm	Ø500mm	Ø500mm
Electric Source	200V - 1ph	400V - 3ph	200V - 3ph	200V - 1ph	400V - 3ph
Air volume	110 M <sup>3</sup> / min	190 M <sup>3</sup> / min	190 M <sup>3</sup> / min	190 M <sup>3</sup> / min	190 M <sup>3</sup> / min
R.P.M.	3000	3600	3600	3600	3600
Output	1.5 kw	1.5 kw	3.7 kw	3.7 kw	3.7 kw
Weight	28 kgs	28 kgs	35 kgs	35 kgs	35 kgs

## Safety Instructions

- Shut off the power urgently when any abnormalities occur in operation.
- The unit must not be installed at place that suffers from severe water leakage.
- It's absolutely prohibited to insert finger or thin bar to the safety grille guard for avoiding being injured or damaging the appliance
- young children should be supervised to ensure that don't play with the appliance.

## Operation

- Turn on/off the switch button to make the unit run/stop
- Running the air-ventilation fan can exhaust odors and steam in a quick and efficient way.
- The VF series air-ventilation fan can be widely used in underground cable maintenance, shipping marking, fire fighting, piping construction, oil machinery, chemical machinery, medicine machinery and other hazardous situation for ventilation .

## Maintenance

- a. Shut off power before cleaning or maintenance.
- b. Wipe casing and impeller with care using a soft cloth soaked with water or neutral detergent ensure the motor or other electrical parts cannot touch the water .
- c. Lubricate axles after approx 1000 hours of running.

## Dimensional Data

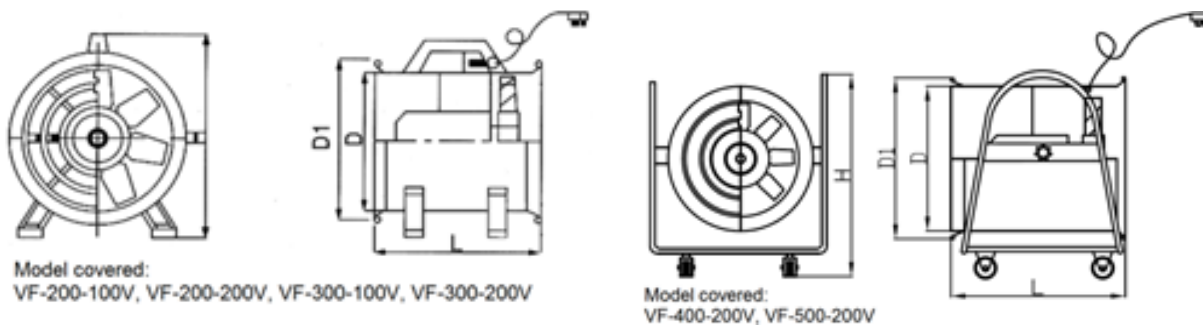

## Model covered

Model Number	L	D1	D	H
VF-200-100V	350	270	210	330
VF-200-200V	340	275	205	330
VF-300-100V	385	380	305	430
VF-300-200V	375	380	305	430
VF-400-200V	445	480	405	705
VF-500-200V	470	580	505	765

## EU DECLARATION OF CONFORMITY

We hereby certify that the Listed Product stipulated below comply with all relevant provisions of the machinery directive (2006/42/EC) and the national laws and regulations adopting this directive.

Description : Electric Portable Ventilation Fans

Model Number : VF400-110V

Date : <<Date>>

Serial Number : <<Serial No>>

Is in conformity with the provisions of the following European Directives: (2011/65/EU) Machinery Safety and Harmonized standards

ISO 12100-1: 2010: Safety of Machinery –general Principles for Design –Risk Assessment and Risk Reduction.

Registered Office : 416 Gundecha Industrial Complex, Akuril Road,  
Kandivali East, Mumbai – 400101, Maharashtra, India.

Web site : [www.teryair.com](http://www.teryair.com)

Works : A-1, Tirupati Udyog Nagar, Sativali Road, Vasai East,  
Palghar – 401208, Maharashtra, India.

CE certification registration no – C E 16831/2

Issued by – BMQR Certifications Pvt Ltd.  
[www.cemarking-india.com](http://www.cemarking-india.com)

Valid Till – 03/11/2025

Signed for and on behalf of



TERYAIR EQUIPMENT PVT. LTD.

Place of Issue : Vasai

Date : <<Date>>



# Warranty Certificate

Every product manufactured by Teryair  
is built to meet the highest standards of quality.

Teryair warrants that the Products, accessories and parts manufactured or supplied by the company be free from defects in material and workmanship for a period of six months from date of Teryair authorized dealer invoice to customer, or one year from date of Teryair invoice to dealer, whichever is earlier. Failure due to normal wear, misapplication, or abuse is, of course, excluded from this warranty.

Since the use of Teryair products and parts is beyond our control, Teryair cannot guarantee the suitability of any product or part for a particular application and Teryair shall not be liable for any consequential damage or expense arising from the use or misuse of its products on any application. Teryair does not warranty bought out products or components such as electric motors and hardware but will assist in directing warranty queries to the dealer/manufacturer responsible. Teryair responsibility is limited solely to replacement or repair of defective Teryair products or components.

Dealer/End User shall have no right or remedy and Teryair shall have no liability or obligation under the warranty, if: (i) a Product is altered, changed, modified or tampered with in any way; (ii) a Product is damaged after deposit with the transporter for shipment; (iii) a Product is not properly preserved, packaged, stored, processed or handled after receipt; (iv) a Product is not used and maintained in accordance with Teryair's recommended operating and maintenance manuals, instructions and procedures, if any; (v) a Product is not properly incorporated or installed in, or not properly combined with, an Other Product; (vi) the issue with a Product is directly or indirectly attributable to, or directly or indirectly results from or arises out of, a failure, substandard performance or other issue with another product, material, component or part not supplied by Teryair; (vii) the issue with a Product is directly or indirectly attributable to, or directly or indirectly results from or arises out of, compliance with any design, specification or other specific requirement of Dealer/End User; (viii) a Product is used in a manner, with a substance or for a purpose other than the normal manner, substance and purpose for which it is intended or is otherwise subjected to abnormal use or service; (ix) a Product is subjected to a power surge, brown out or other similar occurrence; (x) the issue with a Product is directly or indirectly attributable to, or directly or indirectly results from or arises out of, normal wear and tear of such Product (including, without limitation, things such as worn seals, diaphragms, balls, O rings, gaskets, chisels, cutters, hoses and other such wearing components; (xi) the issue with a Product is directly or indirectly.

Model Number : VF400-110V  
Serial Number : <<Serial No>>  
Dated : <<Date>>

M Yadav, Q.A. Manager  
(Company Seal)

This page is intentionally  
Left blank.