

Operation and Maintenance Guide

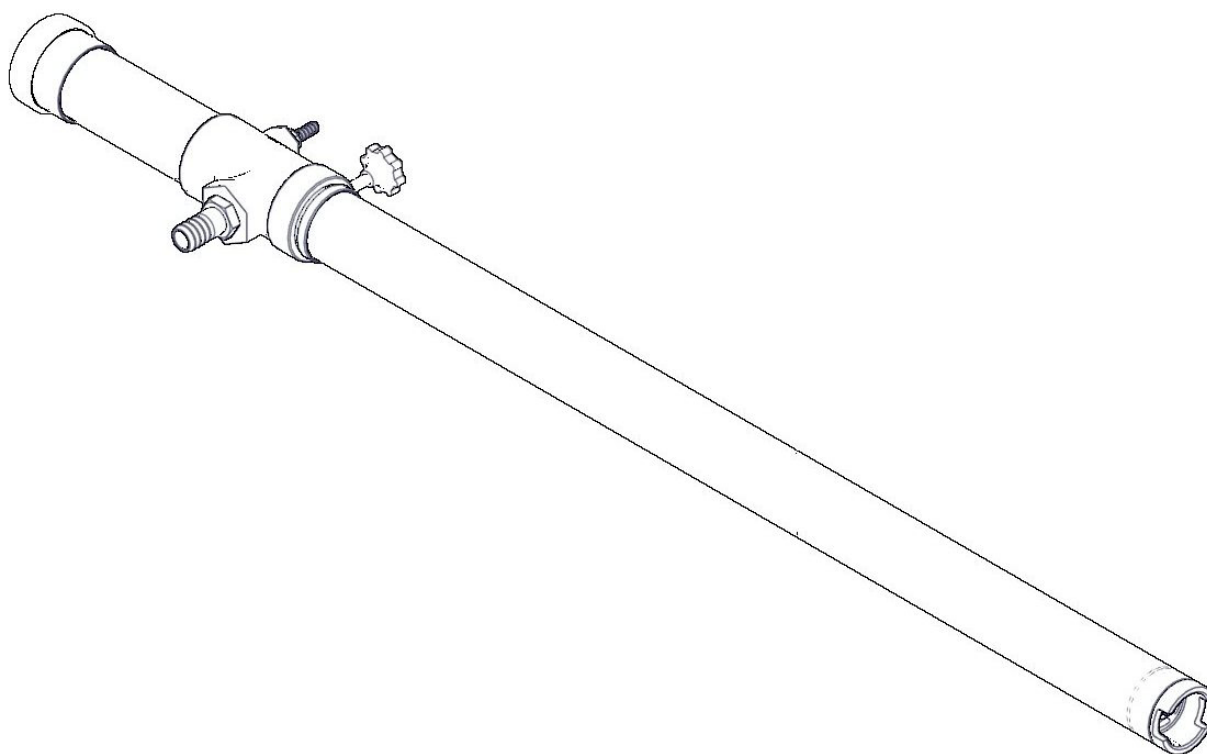

BP 10

Models	Descriptions	IMPA Number
BP-10	Barrel pump	59 16 53

Read this manual carefully before installing, operating or servicing this equipment. It's the responsibility of the employer to ensure this manual is read by the operator. Please preserve this manual.

Table of Contents

3	Introduction
3	Technical Data
3	Safety Instructions
4	Operating Instructions
4	Suggested Lubricants
5	Troubleshooting
6	Disassembly and Re-assembly
7	Exploded View for BP-10
8	Exploded View Detail A for BP-10 Pump
11	Bill of Materials for BP-10
12	Repair Kits for BP-10
13	Eu Declaration Of Conformity
14	Warranty Certificate

Introduction

Teryair Pneumatic Barrel (Drum) Pumps are ideally suited for transferring light oils from barrels. They can be directly inserted into a barrel and screwed onto the bung by means of the provided adaptor. They can be inserted into most barrels and operate over a range of air inlet pressures.

Technical Data

Specification	BP-10
IMPA Number equivalent	59 16 53
Tube Diameter	55mm
Air inlet	¼" NPT
Fluid Outlet	¾" NPT
LPM	44 litres
Air Consumption, m ³ /min	0.27
Weight, Kgs	5.3 kgs

Safety Instructions

Following symbols are used through out this manual.

Warning

Warning: If not followed could cause personal injuries

Caution

If not followed could result in damage to equipment.

Warning

This manual must be read and the operating instructions carefully followed.

Warning

Operators under eighteen not allowed to operate this Pump. Operators must be made familiar with the instructions in this manual before attempting to operate the pump.

Caution

Use only genuine Teryair or Teryair approved accessories.

Caution

Completely turn off the Pump and disconnect air supply line before attempting any service. Read Assembly and Disassembly instructions.

Caution

A regular maintenance after every 500 hours of operation will greatly add to the durability of the pump.

Warning

Take care not to exceed the maximum 6 bar (90 psi) supply air pressure. Use a filter and regulator and lubricator as close to the Pump inlet as the operation will allow ensuring a clean and regulated and lubricated airflow.

Caution

Keep hoses in good condition. Check hoses for signs of wear, cracks & bulges and ensure that they are secure. Accidental disconnection while hose is pressurized makes the hose whip and can be a safety hazard.

Caution

Please check the hose connection prior to starting pump. Store these pump in secure & dry environment. Do not allow the pump to run unattended. Do not modify this pump in any way as this will invalidate the warranty and could lead to serious injury.

Operating Instructions

Barrel Pump Is Rugged Dependable Equipment Designed To Give You Years Of Satisfactory Service. Follow The Instructions Mentioned Here To Enhance The Life And Performance Of Your Pump.

Daily Before Operating

Disconnect And Pour In 1 To 2 Ounces Of Recommended Oil Into The Pump And Reconnect Hose After Blowing Out Any Accumulated Dirt In The Hose Line Before Connection

Lubrication Requirements

Always Install A Line Lubricator On The Airline As Close To The Pump As Possible. A Filter Regulator Lubricator Unit (Frl)Is Strongly Recommended. Keep The Lubricator Bowl Topped Up With A Recommended Grade Of Oil And Check That The Oil Is Reaching

The Pump. Running The Pump Without Lubrication Is Likely To Cause Damage To The Components Causing Premature Replacement.

Air Supply

The Pump Works Best At 6 Bar (90 Psi) Air Pressure. The Air Should Be Clean, Dry, And Lubricated. Install An Frl Unit As Close As The Operation Will Permit.

Hoses

Daily Before Operation Check The Hoses, Especially The High-Pressure Hoses For Damage Or Leaks

Use Genuine Teryair Spares And If Possible Mention The Serial Number Of The Pump When Ordering Spares.

Suggested Lubricants

Brand	Above 27 Deg C (From 5 Deg C to 27 Deg C	Below 5 Deg C
Shell	Toona R 72	Toona R 41	Toona R 27
Mobil	Almo 529	Almo 527	Almo 525
Esso	--	Arox EP.65	Arox EP.45
Caltex	Rando Oil 100	Rando Oil 100	Rando Oil 46
Cp	--	--	Airolene Tool Oil
Texaco	Regal Oil F (R&O)	Regal Oil PE (P&E)	Regal Oil PE (R&O)
Daltron	Silkolene 881	Silkolene 548/T	Silkolene 733
Burmah Castrol	Castrol RD Oil 3	Castrol RD Oil Light	Megna SPX
Duckham	Garnet 7	Garnet 6	Zero Fio 5
Sternol	Merlin 87	Merlin 71	Merlin 54
Petrofina	Purifoc 53	Purifoc 46	Purifoc 32
Chevron	Vistac Oil 18X	Vistac Oil 19X	Vistac Oil 9X
Indoil	Servo Sbyn -22	--	--

Troubleshooting

Serial No	Description	Causes	Remedial Action
1	Pump stopped and will not start.	Insufficient Air Pressure	Check air pressure is as recommended at the pump air inlet
		Air Filter Blocked	Check if debris has clogged the inlet filter on the FRL unit/pump inlet air valve (some models have air filter on the air inlet valve) and ensure clear passage of air
		Internal damage or excessive wear on components	Proceed to dismantle the pump, examine component for wear, replace any worn components, re assemble carefully as instructed in this manual and re start the pump.
2	Pump runs slowly, poor delivery.	Insufficient or wrong lubricant in the air supply.	Ensure that the lubricant is as per the recommended chart, a thicker lubricant often makes the air valve work sluggishly.
		Internal damage or excessive wear on components	Proceed to dismantle the pump, examine component for wear, replace any worn components, reassemble carefully as instructed in this manual and re start the pump.

Disassembly and Re-assembly

- a. Unscrew Hose Nipple (43) and Hose Nipple (44) from Piston Housing (23). Unscrew Bottom Cap (41) from Barrel Pipe (37) and Drain out remaining oil from barrel pipe (37).
- b. Unscrew Hex Bolt (42) and Nylock Nut (38) from Barrel Cap (36), Now remove Bush (40) and Plain Washer (32) from Barrel Cap (36) and replace it with new. (If found damaged)
- c. Hold the Piston Housing (23) and using a pipe wrench Barrel Pipe (37) to unscrew it. Remove O-ring (27) from Piston Rod (18) then remove Lock Pin (19) from Piston Rod (18) and replace it with new ones. (If found damaged)
- d. Now remove piston assembly from Piston Rod (18). Now unscrew Nylock Nut (33) from Connecting Shaft (28) to remove Plain washer (32) and Plain Washer (4).
- e. Now remove O-ring (21) and Piston Seal (29) from Piston (30) grooves and replace it with new ones. (If found damaged)
- f. Now hold Piston Housing (23) to unscrew Air Cylinder (20) from Piston Housing (23).
- g. Now remove Piston (13) and Piston Rod (18) assembly from Exhaust Shield (3) side of Piston Housing (23).
- h. Now unscrew CSK Screw (10) with Spring Washer (2) from Upper Backing Plate (11) from Piston (13).
- i. Now remove Upper Backing Plate (11) from Piston (13). Now remove Distance Piece (12) from Piston (13) and replace it with new ones. (If found damaged)
- j. Now unscrew Piston Rod (18) from Piston (13) . Now remove Rest plate from Piston Rod (18).
- k. Now remove Spring (16), Locking plate (15) and Piston Seal (14) from Piston (13) and replace it with new ones. (If found damaged).
- l. Unscrew Knob (35) from Barrel Cap (36). Now remove Barrel Cap (36) from Barrel Pipe (37). Now remove Spring Plate (34) from Barrel Cap (36) and replace it with new ones. (If found damaged).
- m. Now unscrew Pan head screw (10) with Spring washer (2) from Exhaust Shield (3). Now remove Exhaust Shield (3) and Plain Washer (4).
- n. Now unscrew Cylinder Cap (7) from Cylinder (20). Now remove Conical Spring (9) and Washer For Conical spring (8) from Cylinder Cap (7).
- o. Now remove Tube (5) and O-ring (6) and replace it with new one. (if found damaged)
- p. Please pay attention to the assembly of certain components. Such as Upper Plate (11) and Lower Plate (15) must be assembled in the correct direction as shown in exploded view. (Refer Detail C)
- q. Piston Seal (14) and Piston seal (29) must be assembled in correct direction. Check that the Y portion in seal (14) is facing downwards i.e. towards the top of the pump. And the Y portion of seal (29) is facing upwards i.e. towards the bottom of the pump.
- r. Now follow the above steps in reverse manner to reassemble the Barrel Pump.

Exploded View for BP-10

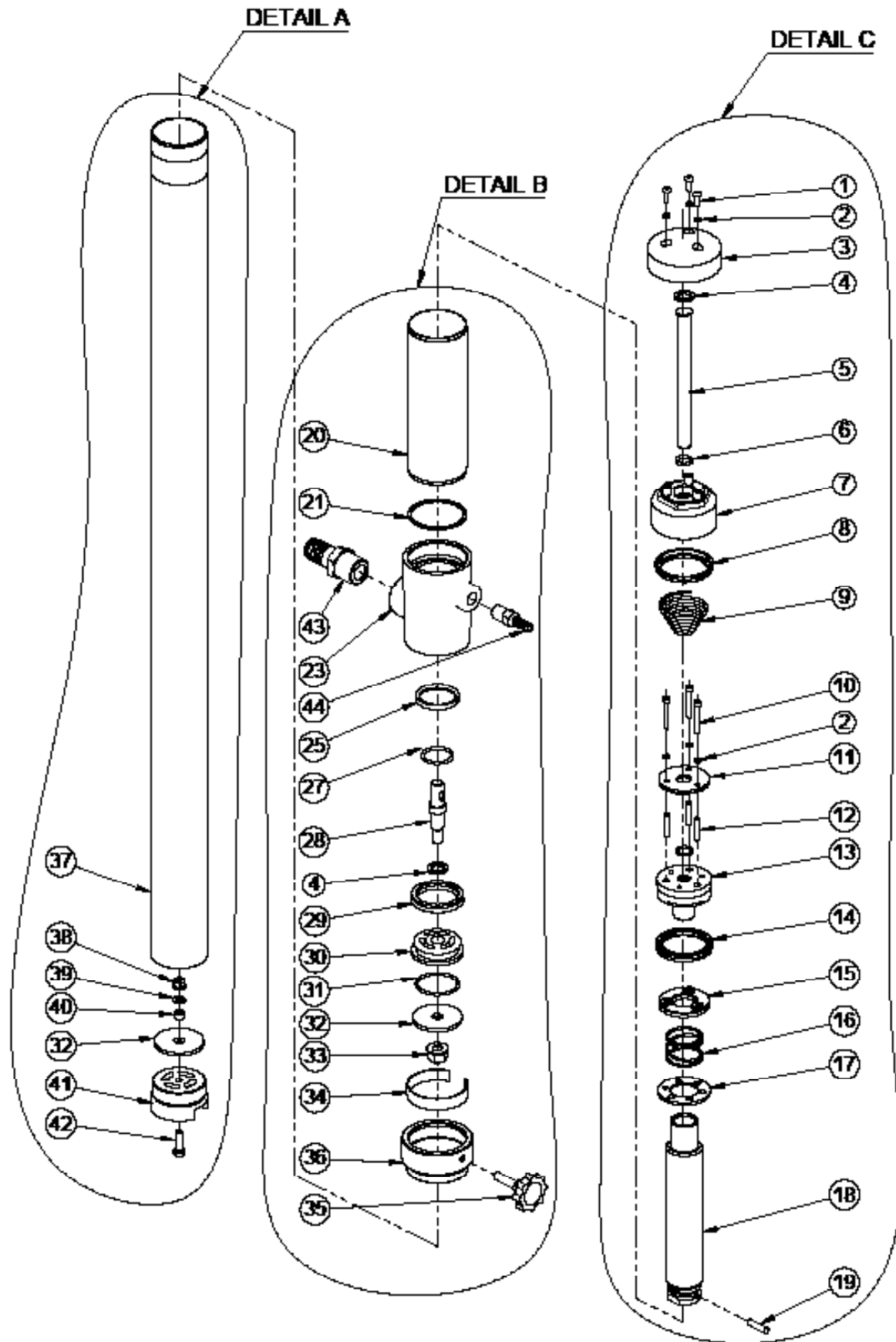

Exploded View Detail A for BP-10 Pump

DETAIL A

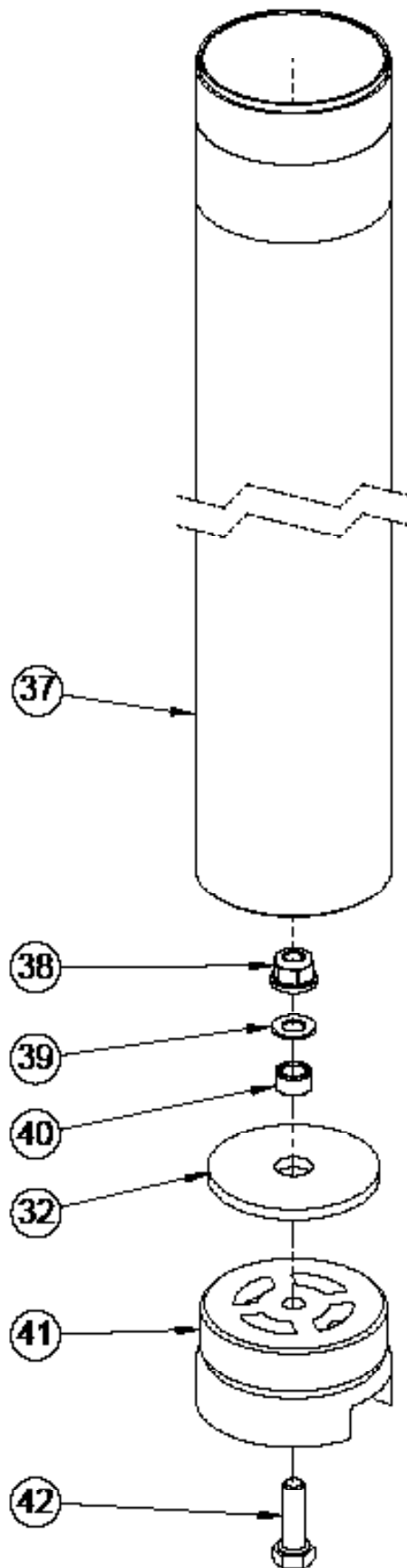

Exploded View Detail B for BP-10 Pump

DETAIL B

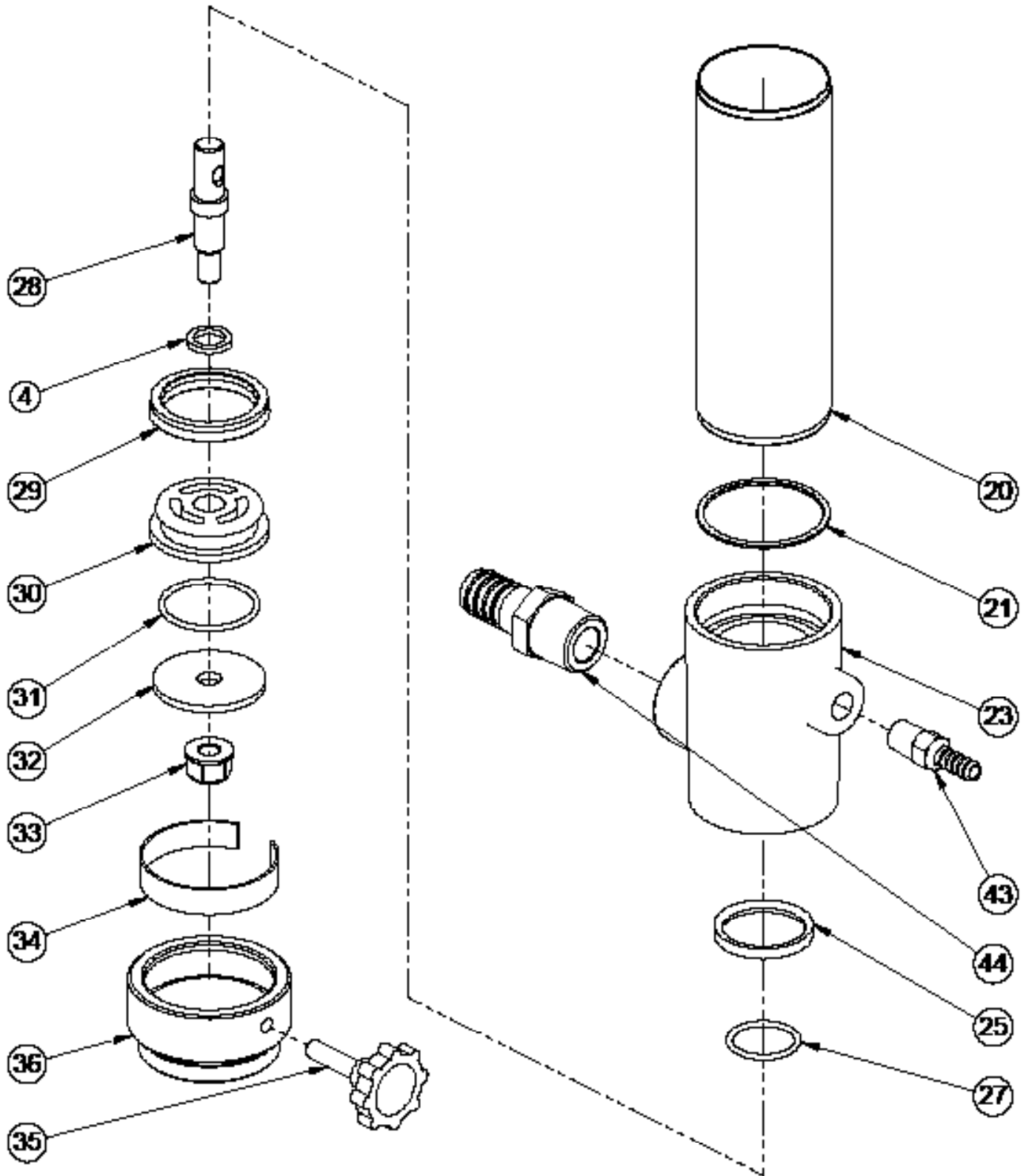

Exploded View Detail B for BP-10 Pump

DETAIL C

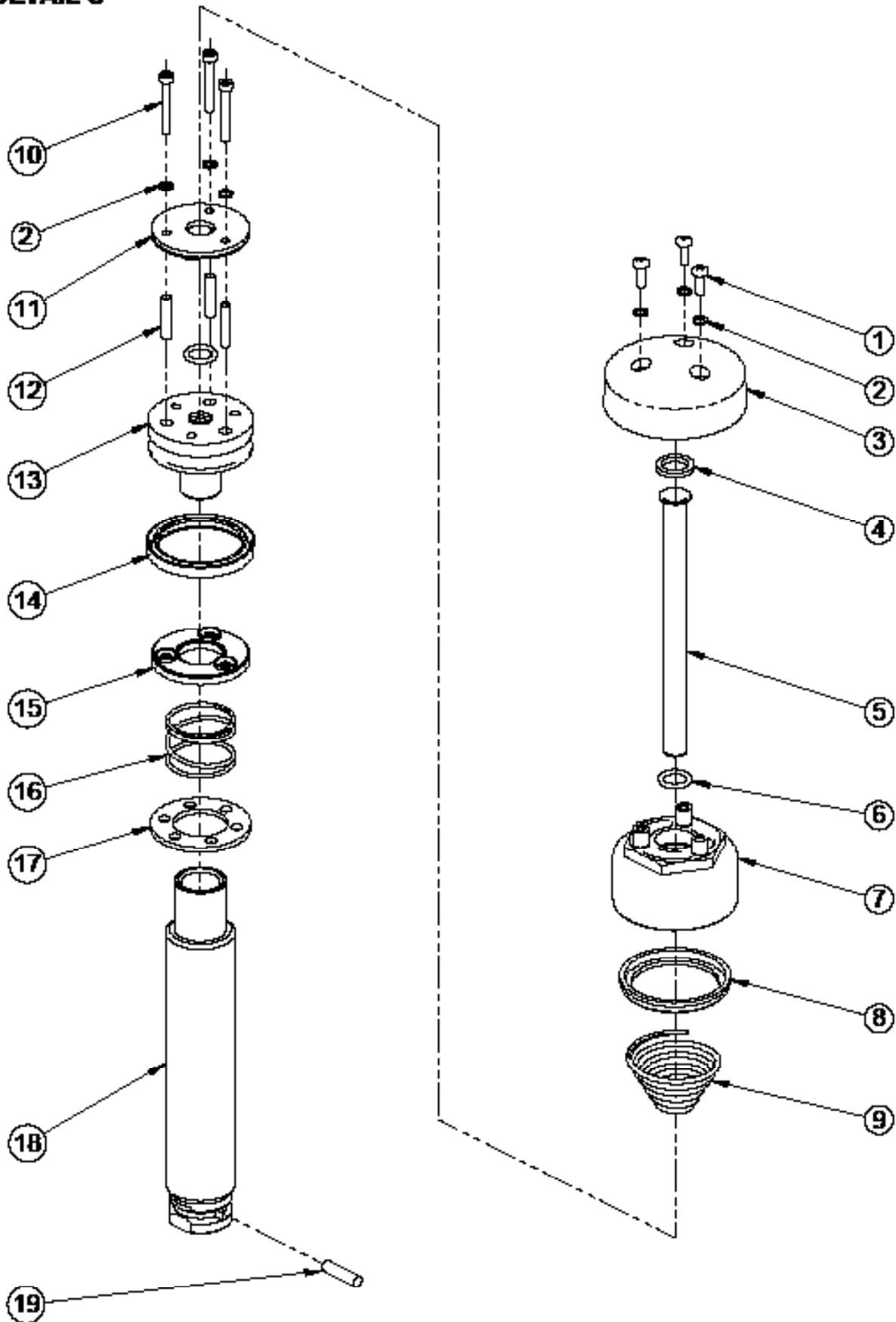

Bill of Materials for BP-10

Sr.No	Description	Part Number	BP-10	Sr.No	Description	Part Number	BP-10
1	PHILIPS PAN HEAD SCREW	298 00 03	3	21	WASHER FOR PISTON HOUSING	298 00 63	1
2	SPRING WASHER	298 00 04	6	23	PISTON HOUSING	298 00 57	1
3	EXHAUST SHIELD WITH DIVIDER	298 08 01	1	25	PISTON ROD SEAL (CORD RING)	298 00 47	1
4	PLAIN WASHER	298 00 05	2	27	O' RING (LOCK PIN)	298 00 41	1
5	TUBE (EXAUST)	298 00 17	1	28	CONNECTING SHAFT	298 00 43	1
6	O' RING (TUBE)	298 00 07	2	29	PISTON SEAL (OIL)	298 00 61	1
7	CYLINDER CAP	298 00 15	1	30	PISTON (OIL)	298 00 49	1
8	WASHER FOR CONICAL SPRING	298 00 13	1	31	O' RING FOR OIL PISTON	298 00 55	1
9	CONICAL SPRING	298 00 11	1	32	PLAIN WASHER	298 00 53	2
10	SOCKET HEADED CAP SCREW	298 00 23	3	33	NYLOCK NUT	298 00 45	1
11	UPPER BACKING PLATE	298 00 25	1	34	SPRING PLATE	298 00 91	1
12	DISTANCE PIECE	298 00 21	3	35	KNOB TYPE LOCK SCREW	298 00 89	1
13	PISTON (AIR)	298 08 02	1	36	BARREL CAP	298 21 77	1
14	PISTON SEAL (AIR) BIG	298 00 31	1	37	BARREL PIPE	298 00 65	1
15	LOCKING PLATE	298 00 27	1	38	NYLOCK NUT	298 00 75	1
16	SPRING	298 00 35	1	39	PLAIN WASHER	298 00 90	1
17	REST PLATE	298 00 85	1	40	BUSH LOCKING PLATE	298 00 71	1
18	PISTON ROD	298 08 38	1	41	BOTTOM CAP	298 00 67	1
19	LOCK PIN	298 00 39	1	42	HEX HEAD BOLT	298 00 73	1
20	AIR CYLINDER	298 00 19	1	43	HOSE NIPPLE (1/4" NPT)	298 21 02	1
				44	HOSE NIPPLE (3/4"NPT)	298 21 08	1

Repair Kits for BP-10

Illu. No.	Part No.	Description	BP 10
			298 00 14K Repair Kit
6	298 00 07	O' RING (TUBE)	2
8	298 00 13	WASHER FOR CONICAL SPRING	1
11	298 00 25	UPPER BACKING PLATE	1
14	298 00 31	PISTON SEAL (AIR) BIG	1
15	298 00 27	LOCKING PLATE	1
21	298 00 63	WASHER FOR PISTON HOUSING	1
25	298 00 47	PISTON ROD SEAL (CORD RING)	1
27	298 00 41	O' RING (LOCK PIN)	1
29	298 00 61	PISTON SEAL (OIL)	1
30	298 00 49	PISTON (OIL)	1
31	298 00 55	O' RING FOR OIL PISTON	1
35	298 00 89	KNOB TYPE LOCK SCREW	1

EU DECLARATION OF CONFORMITY

We hereby certify that the Listed Product stipulated below comply with all relevant provisions of the machinery directive (2006/42/EC) and the national laws and regulations adopting this directive.

Description : **Pneumatic Barrel Pump**

Model Number : **BP-10**

Is in conformity with the provisions of the following European Directives: (2006/42/EC) Machinery Safety and Harmonized standards

ISO 12100-1: 2010: Safety of Machinery –general Principles for Design –Risk Assessment and Risk Reduction.

Registered Office : 416 Gundecha Industrial Complex, Akuril Road,
Kandivali East, Mumbai – 400101, Maharashtra, India.

Web site : www.teryair.com

Works : A-1, Tirupati Udyog Nagar, Sativali Road, Vasai East,
Palghar – 401208, Maharashtra, India.

CE certification registration no – C E 16831

Issued by – BMQR Certifications Pvt Ltd.
www.cemarking-india.com

Valid Till – 03/11/2025

Signed for and on behalf of

TERYAIR EQUIPMENT PVT. LTD.

Place of Issue: Vasai



Warranty Certificate

Every product manufactured by Teryair
is built to meet the highest standards of quality.

Teryair warrants that the Products, accessories and parts manufactured or supplied by the company be free from defects in material and workmanship for a period of six months from date of Teryair authorized dealer invoice to customer, or one year from date of Teryair invoice to dealer, whichever is earlier. Failure due to normal wear, misapplication, or abuse is, of course, excluded from this warranty.

Since the use of Teryair products and parts is beyond our control, Teryair cannot guarantee the suitability of any product or part for a particular application and Teryair shall not be liable for any consequential damage or expense arising from the use or misuse of its products on any application. Teryair does not warranty bought out products or components such as electric motors and hardware but will assist in directing warranty queries to the dealer/manufacturer responsible. Teryair responsibility is limited solely to replacement or repair of defective Teryair products or components.

Dealer/End User shall have no right or remedy and Teryair shall have no liability or obligation under the warranty, if: (i) a Product is altered, changed, modified or tampered with in any way; (ii) a Product is damaged after deposit with the transporter for shipment; (iii) a Product is not properly preserved, packaged, stored, processed or handled after receipt; (iv) a Product is not used and maintained in accordance with Teryair's recommended operating and maintenance manuals, instructions and procedures, if any; (v) a Product is not properly incorporated or installed in, or not properly combined with, an Other Product; (vi) the issue with a Product is directly or indirectly attributable to, or directly or indirectly results from or arises out of, a failure, substandard performance or other issue with another product, material, component or part not supplied by Teryair; (vii) the issue with a Product is directly or indirectly attributable to, or directly or indirectly results from or arises out of, compliance with any design, specification or other specific requirement of Dealer/End User; (viii) a Product is used in a manner, with a substance or for a purpose other than the normal manner, substance and purpose for which it is intended or is otherwise subjected to abnormal use or service; (ix) a Product is subjected to a power surge, brown out or other similar occurrence; (x) the issue with a Product is directly or indirectly attributable to, or directly or indirectly results from or arises out of, normal wear and tear of such Product (including, without limitation, things such as worn seals, diaphragms, balls, O rings, gaskets, chisels, cutters, hoses and other such wearing components); (xi) the issue with a Product is directly or indirectly.

Model Number : BP-10

A handwritten signature in blue ink, appearing to read "M Yadav", is written over a horizontal line.

M Yadav, Q.A. Manager
(Company Seal)

This page is intentionally
Left blank.